











Assembly Instructions

Caution : You must read this before you proceed

Care & Maintenance



- ⊘  ● Not for commercial use. For residential use only.
- ✓  ● Furniture may scratch floors. We recommend using furniture pads to protect your floors.
- ⊘  ● Do not put hot items directly on furniture surface.
- ⊘  ● Do not clean furniture with harsh cleansers or polish.
- ⊘  ● Do not place furniture under direct sunlight.
- ⊘  ● Do not place furniture near heating or cooling vents.
- ⊘  ● Do not write on furniture without a padded barrier to protect the surface.
- ⊘  ● Do not place furniture outside . For indoor use only.
- ⊘  ● Stains may be removed with mild soap solution and damp cloth.
- ⊘  ● Children should not climb or jump on the furniture.
- ✓  ● Dust and pick-up spills using a clean, non-colored, lint-free cloth.

ASSEMBLY INSTRUCTION

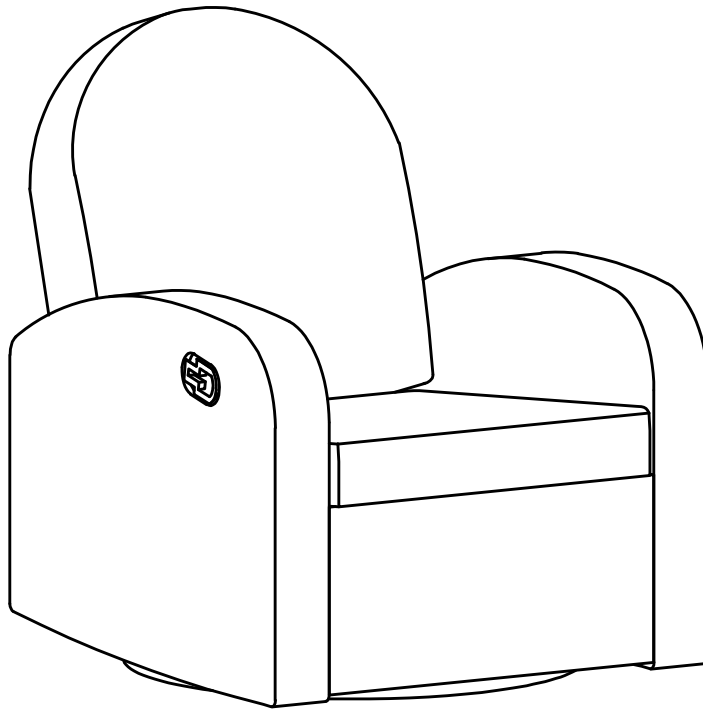

ITEM NO.: N771P363407



N771P363407 - COMPONENT LIST

NO.	DRAWING	QTY	DESCRIPTION
A		1	Seat Frame Body
B		1	Backrest

PARTS LIST

<p>A</p> 	<p>B</p> 
<p>Seat Frame Body x 1 pc</p>	<p>Backrest x 1 pc</p>

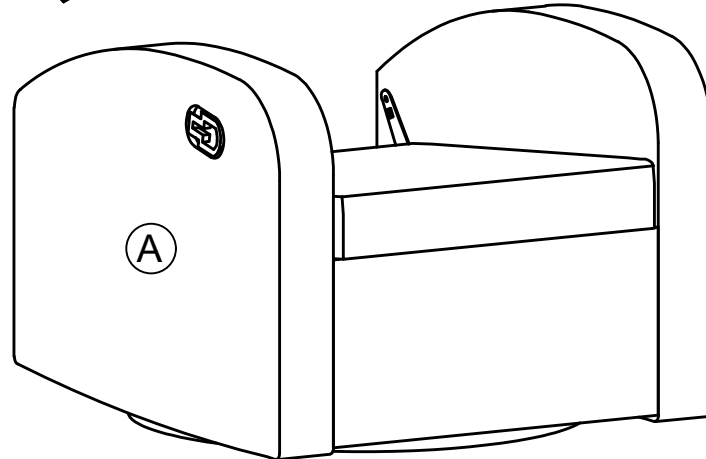
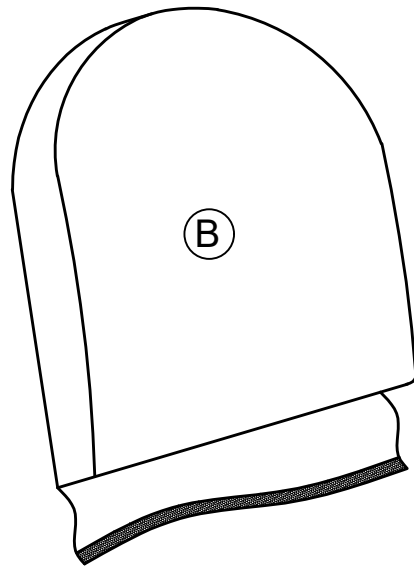

* Take out the (A) (B)

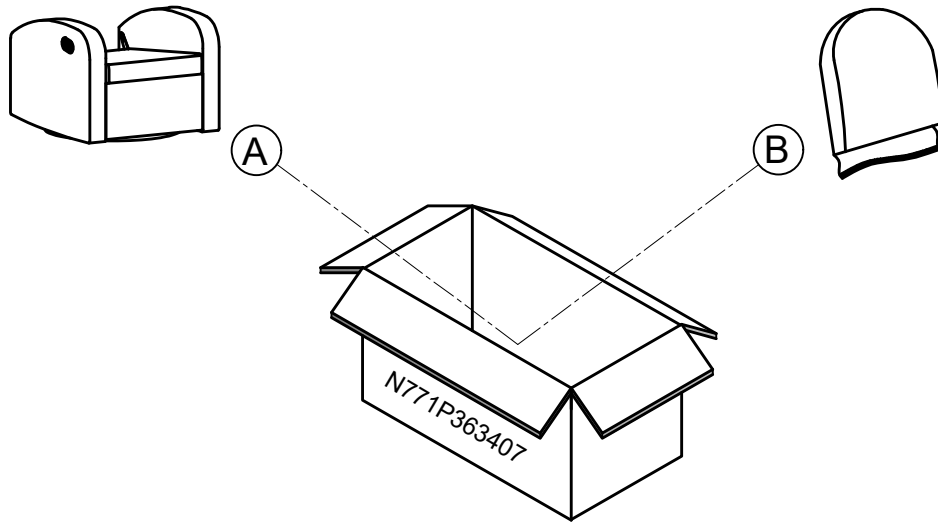

STEP 1:

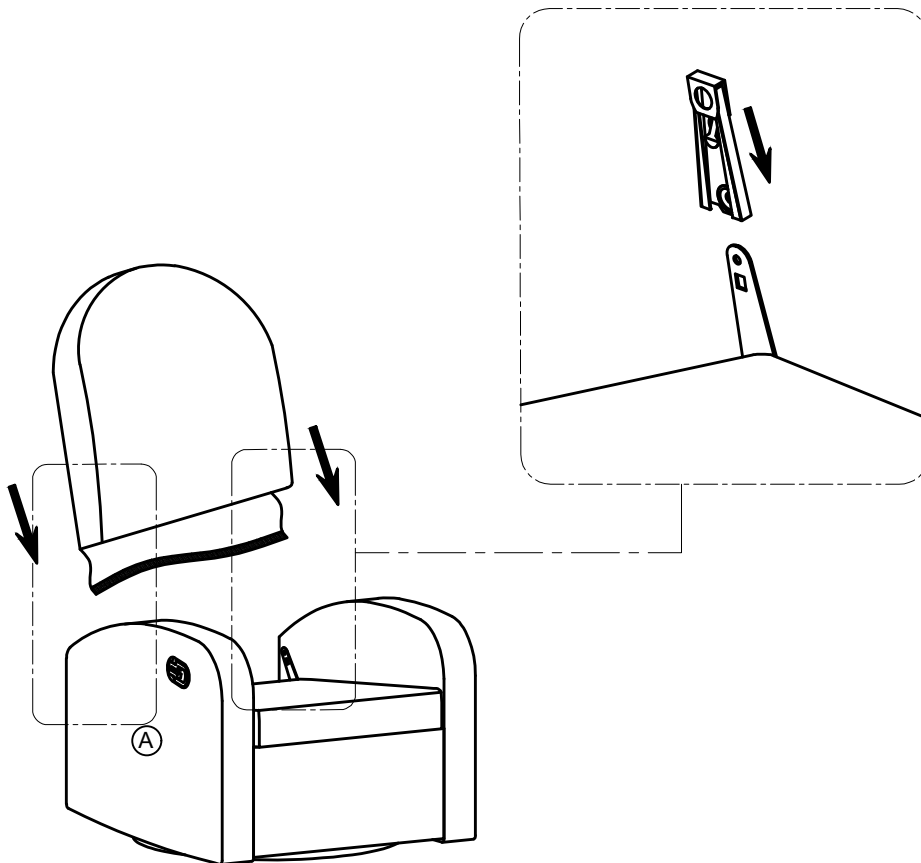

STEP 2:

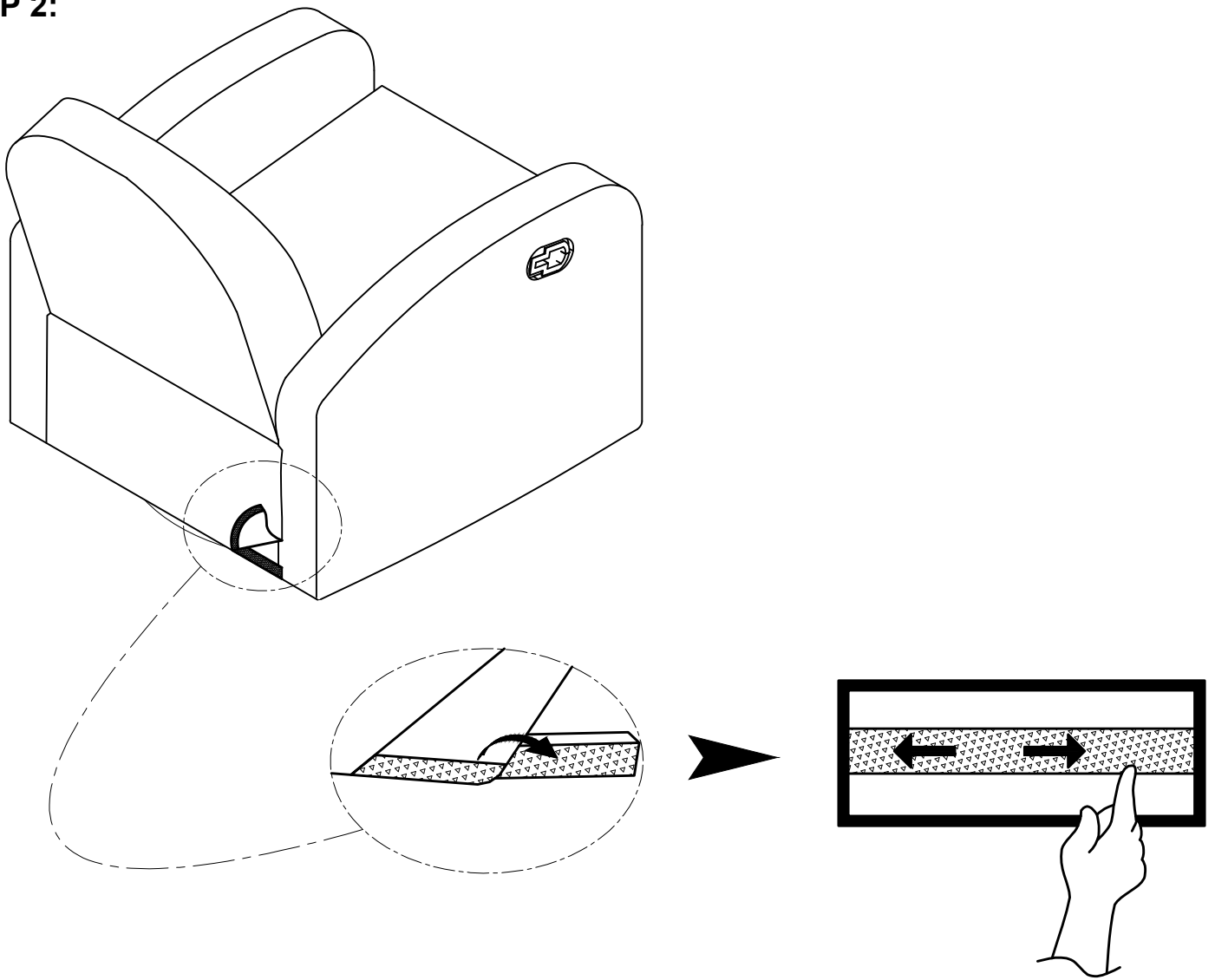

STEP 3:

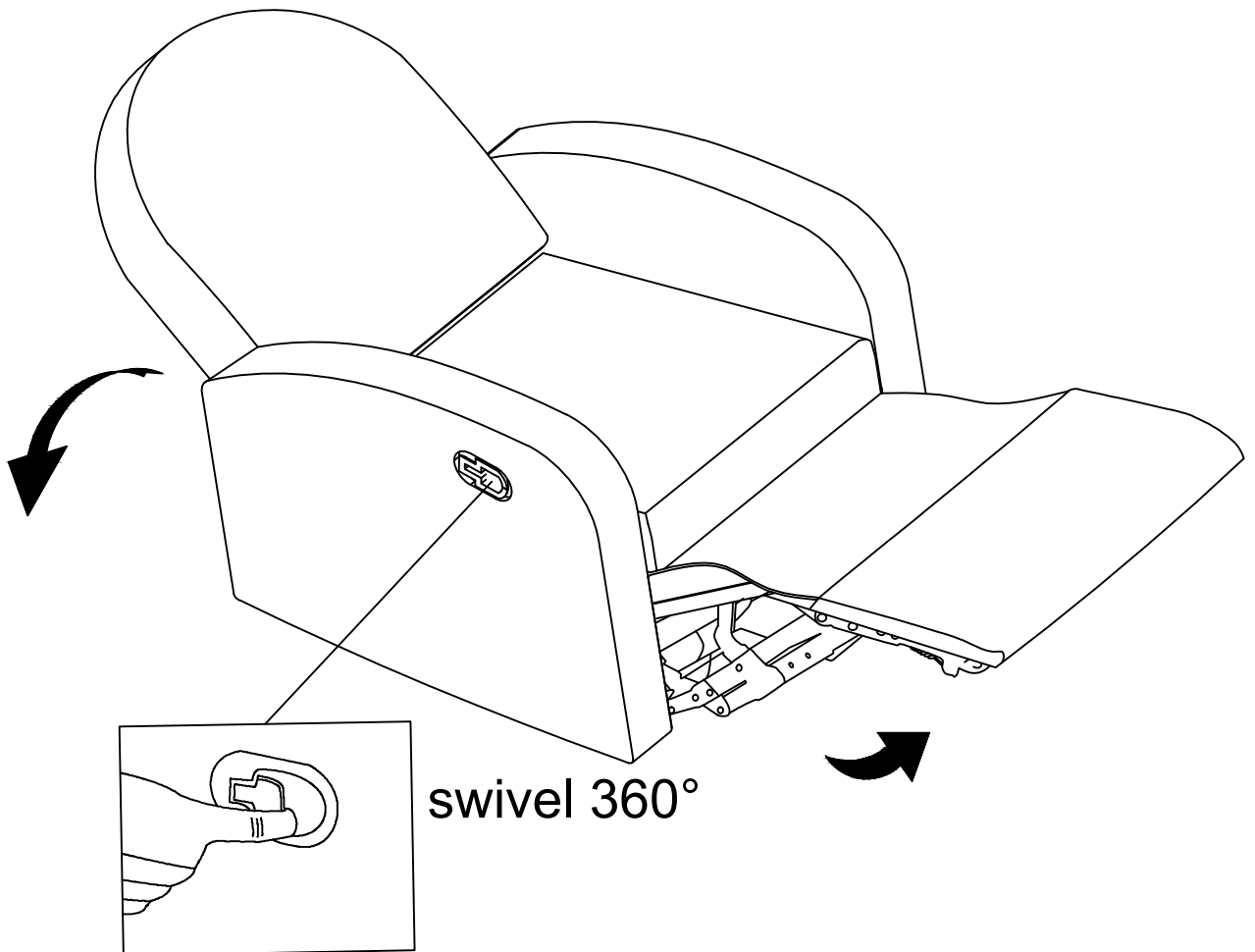

Helpful Hints

- Move your new furniture carefully, with two people lifting and carrying the unit to its new location.
- Your furniture can be disassembled and reassembled to move.
- Clean the product with a soft damp cloth. DO NOT use harsh chemicals or abrasive cleaners.

COMPLETED

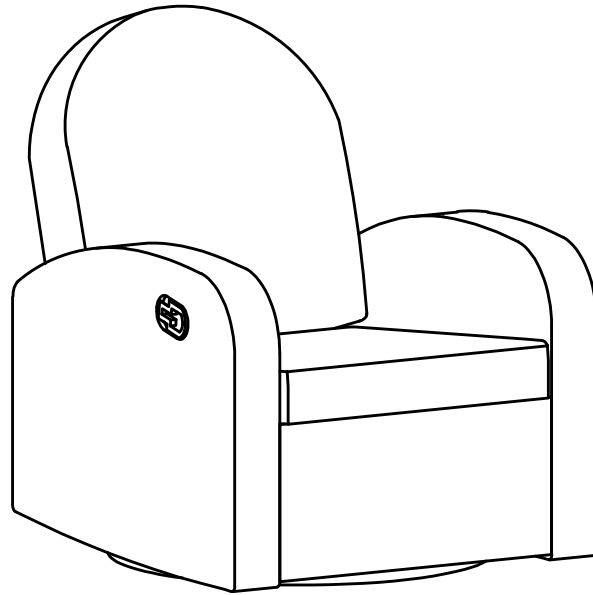

Warning!!



Correct Way to Use



Incorrect Way to Use



Incorrect Way to Use



Incorrect Way to Use



Incorrect Way to Use



Incorrect Way to Use

- Always leave the chair in an upright and closed position after use.
- Keep hands and feet clear of the footrest mechanism and any gaps.
- Do not allow children to play on the chair.
- Do not lean to side to pick up anything while sitting on the chair.
- Do not sit on the arms.
- Do not stand up when the recliner open.
- Only the occupant should operate the chair

User Instructions.

Glider Recliner With Swivel

Please read the Instruction Manual below carefully before use.

This is a Recliner Chair. At anytime in a reclined seat position or in the upright position. You may enjoy the rocking motion by using your body weight in a back-front rocking motion, and swivel motion as well.

Supervise children, when in use of this Recliner.

To get into the Recline position:

Sit into the seat.

Open the trigger on the outside of right armrest.

Use your body weight and push backwards into the seat into a fully reclined position.

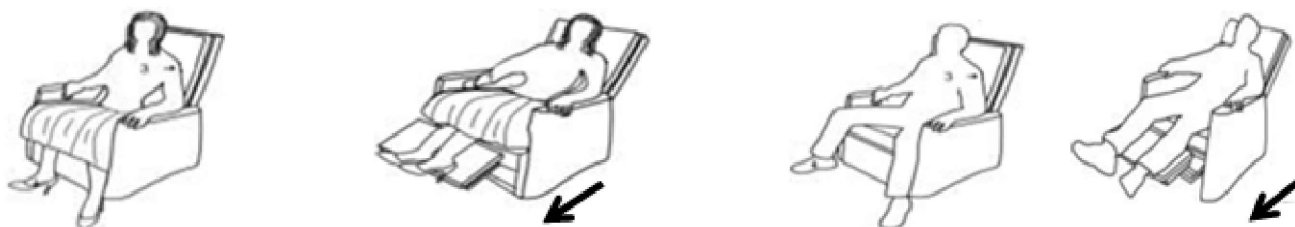

To move the Chair back into the Upright position:

Tilt your body weight slightly forward and upwards.

The seat back will come up to an upright position.

Use your feet to push the Footrest down.

The Chair will automatically lock when it is in the fully upright position.

Where necessary, use your arms help lift/push yourself out of the seat

