

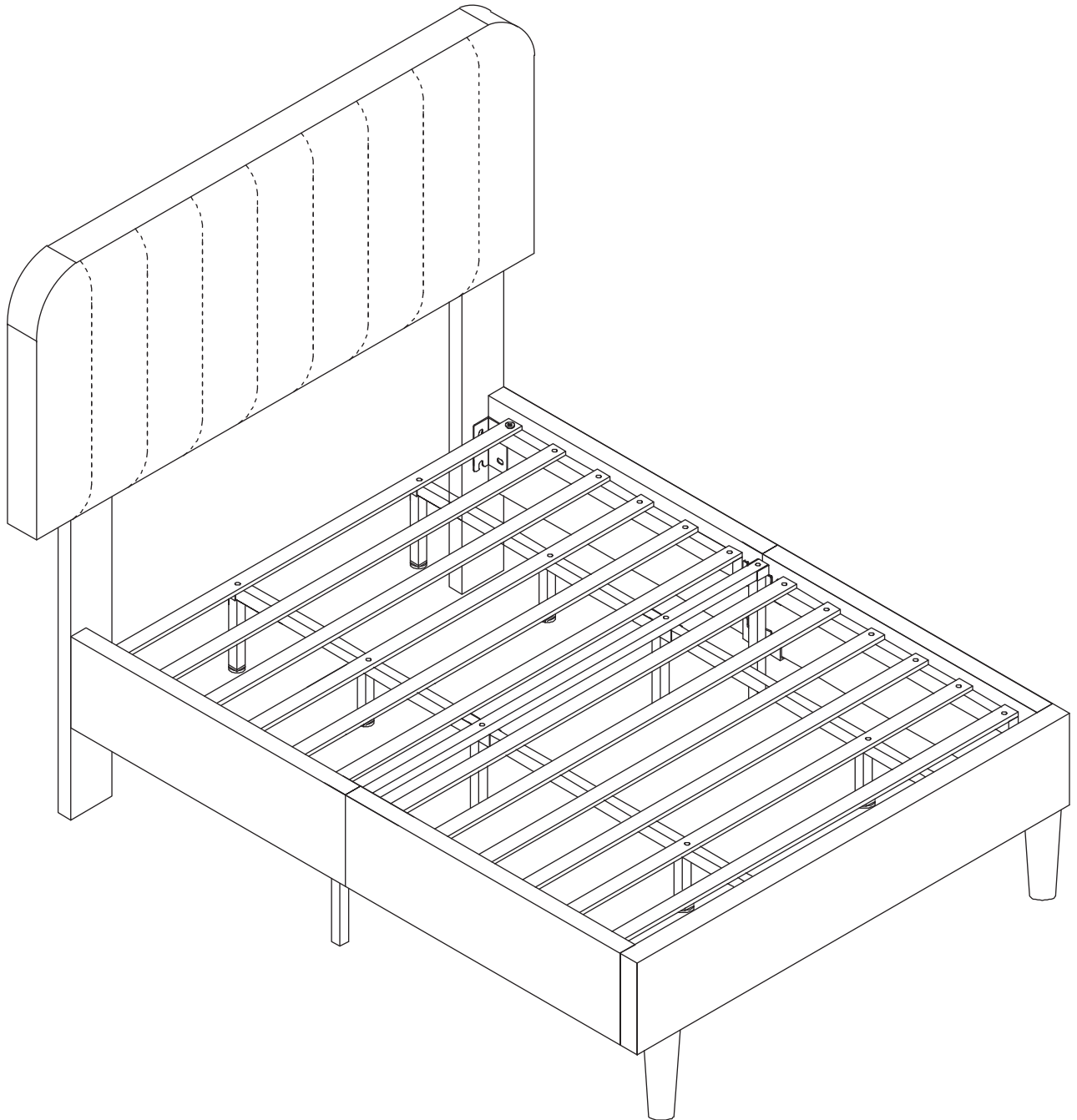

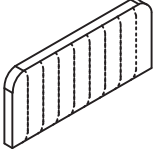

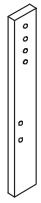



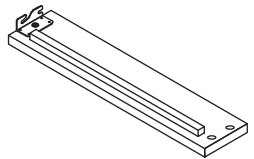
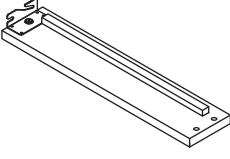
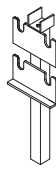
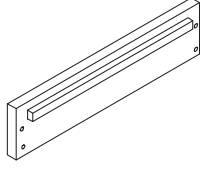
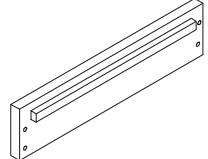
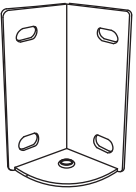
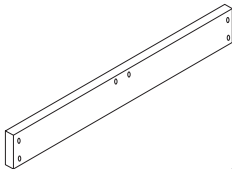
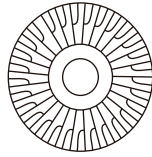
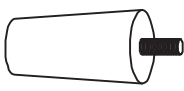

# ASSEMBLY INSTRUCTION

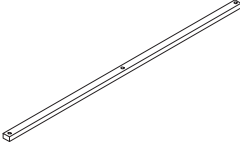
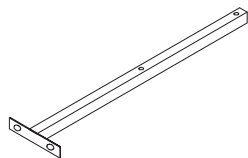
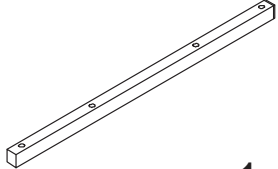
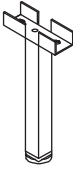

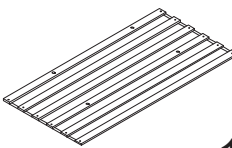
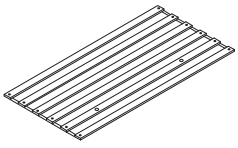
# PARTS LIST

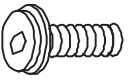
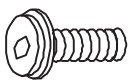
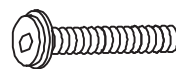
<p><b>A</b></p>  <p>1pc</p>	<p><b>B</b></p>  <p>1pc</p>	<p><b>C</b></p>  <p>1pc</p>	<p><b>D</b></p>  <p>1pc</p>
<p><b>E</b></p>  <p>1pc</p>	<p><b>F</b></p>  <p>2pcs</p>	<p><b>G</b></p>  <p>1pc</p>	<p><b>H</b></p>  <p>1pc</p>
<p><b>I</b></p>  <p>2pcs</p>	<p><b>J</b></p>  <p>1pc</p>	<p><b>K</b></p>  <p>2pcs</p>	<p><b>L</b></p>  <p>2pcs</p>
<p><b>M</b></p>  <p>2pcs</p>	<p><b>N</b></p>  <p>2pcs</p>	<p><b>O</b></p>  <p>2pcs</p>	<p><b>P</b></p>  <p>1pc</p>
<p><b>Q</b></p>  <p>2pcs</p>	<p><b>R</b></p>  <p>6pcs</p>	<p><b>S</b></p>  <p>1pc</p>	<p><b>T</b></p>  <p>1pc</p>

# HARDWARE LIST

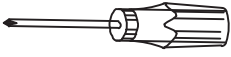
<p><b>1</b></p>  <p>Bolt M6 x 16 20pcs+1</p>	<p><b>2</b></p>  <p>Bolt M6 x 30 10pcs+1</p>	<p><b>3</b></p>  <p>Bolt M6 x 45 12pcs+1</p>	<p><b>4</b></p>  <p>4pcs</p>
<p><b>5</b></p>  <p>6pcs</p>	<p><b>6</b></p>  <p>24pcs+1</p>	<p><b>7</b></p>  <p>1pc</p>	<p><b>8</b></p>  <p>1pc</p>

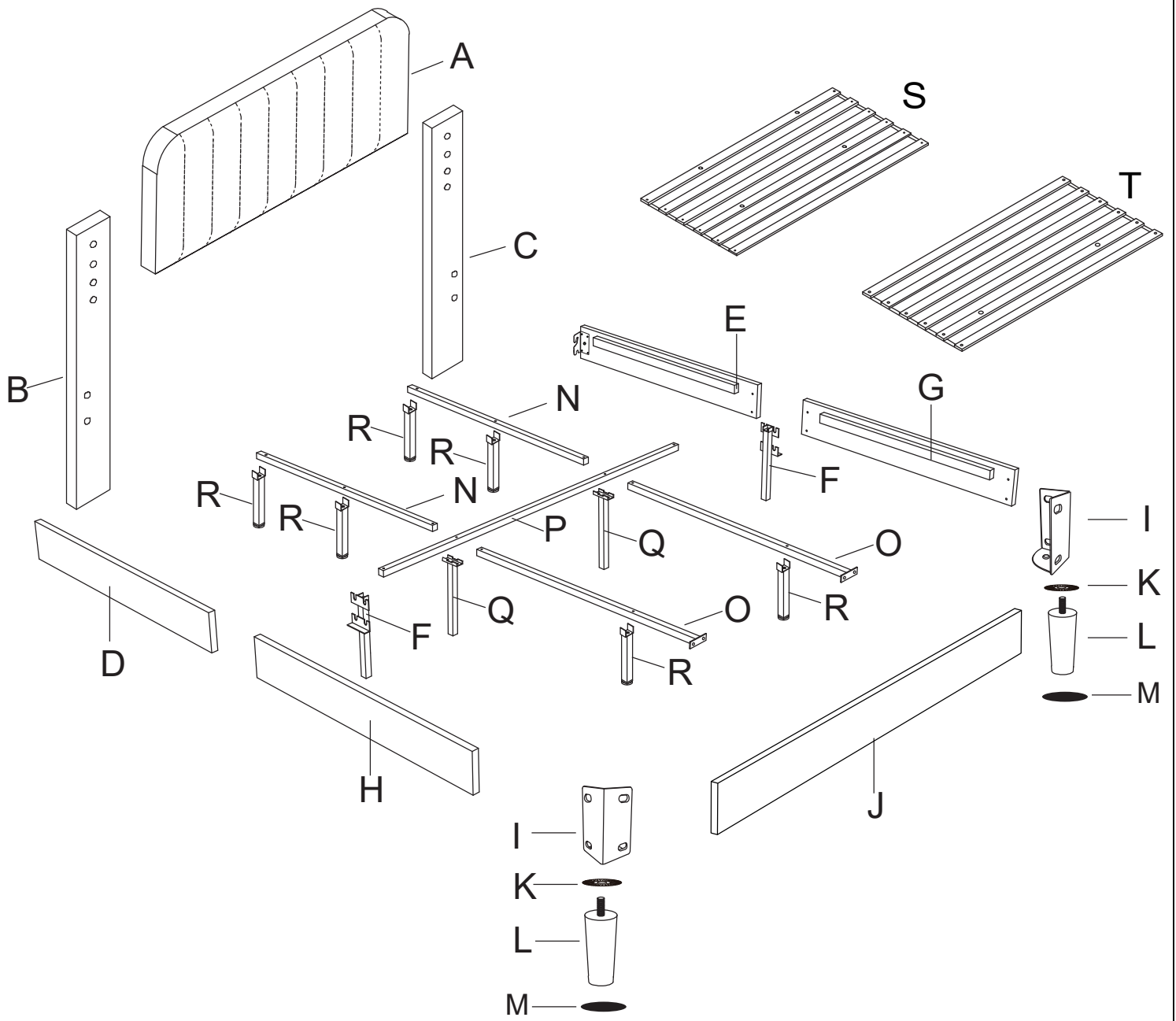

# Step 1

Attach part A (the headboard) to part B and part C (the side rails).

Align the holes and secure them with screws (number 4).

Tips: The vertical position of the headboard can be adjusted between 8.27" (21 cm) and 13.78" (35 cm).

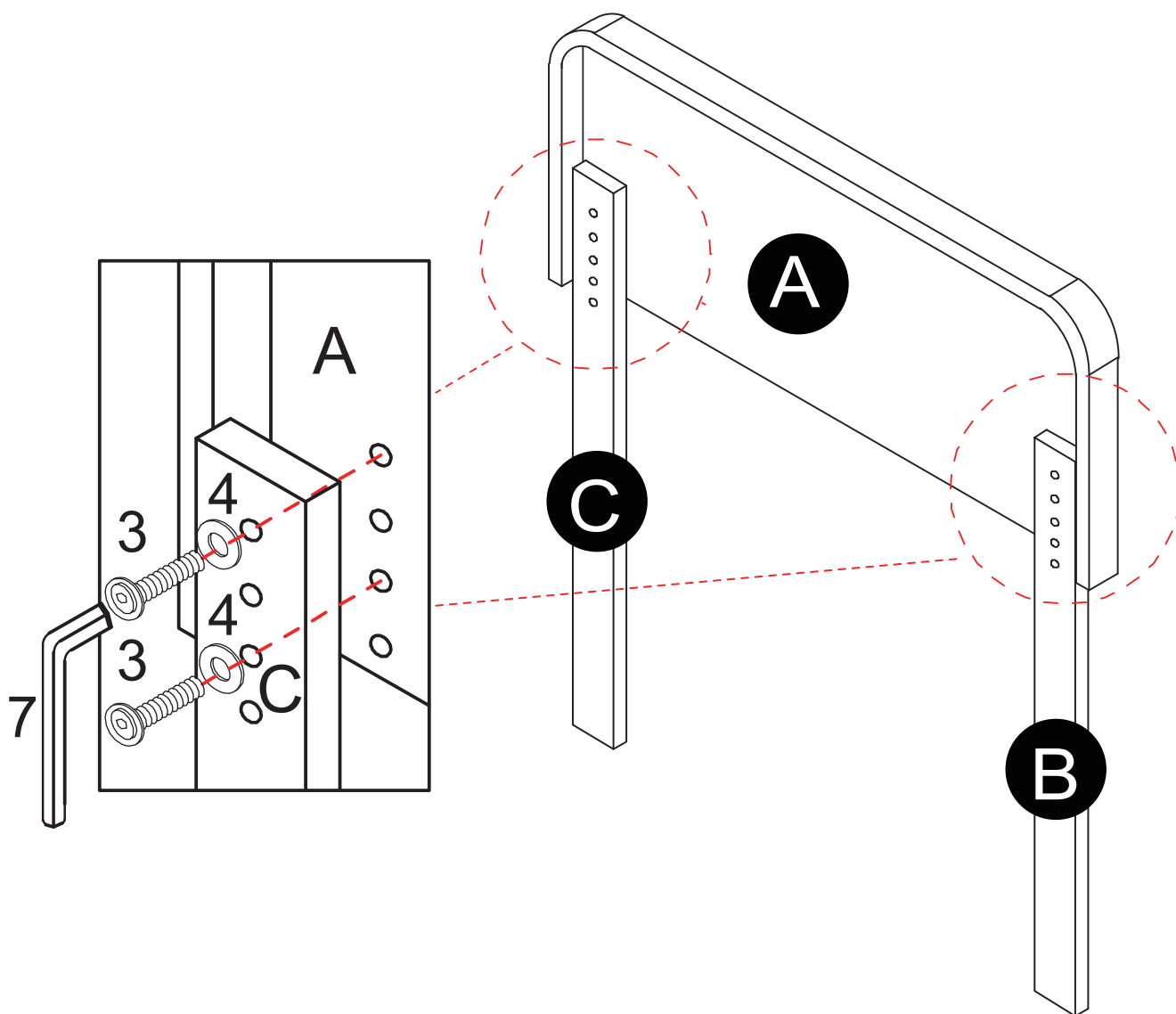

# Step 2

Attach part F to D and E respectively using screw (number 1), and tighten securely.

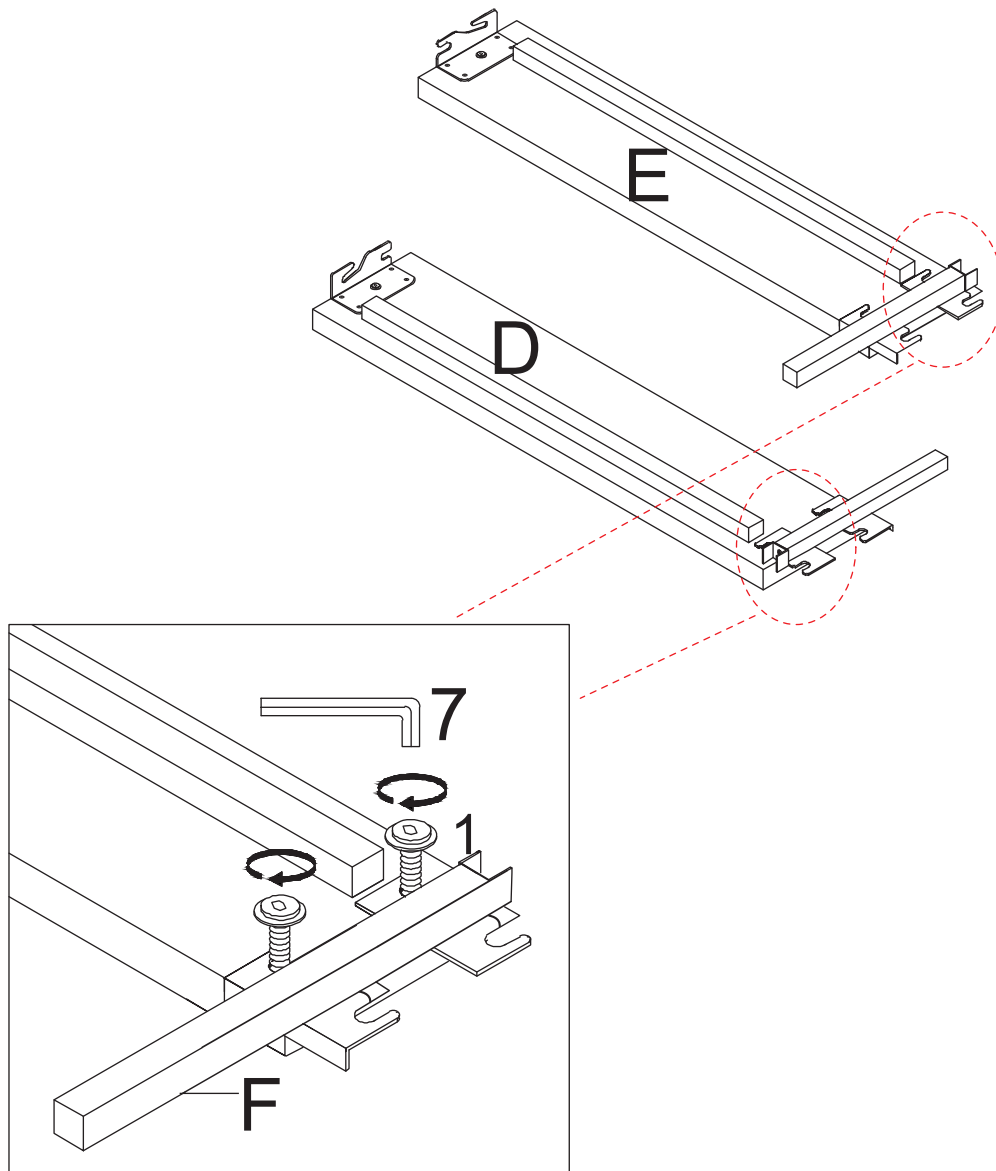

# Step 3

Secure part D to part B and part E to part C respectively using screw (number 2)

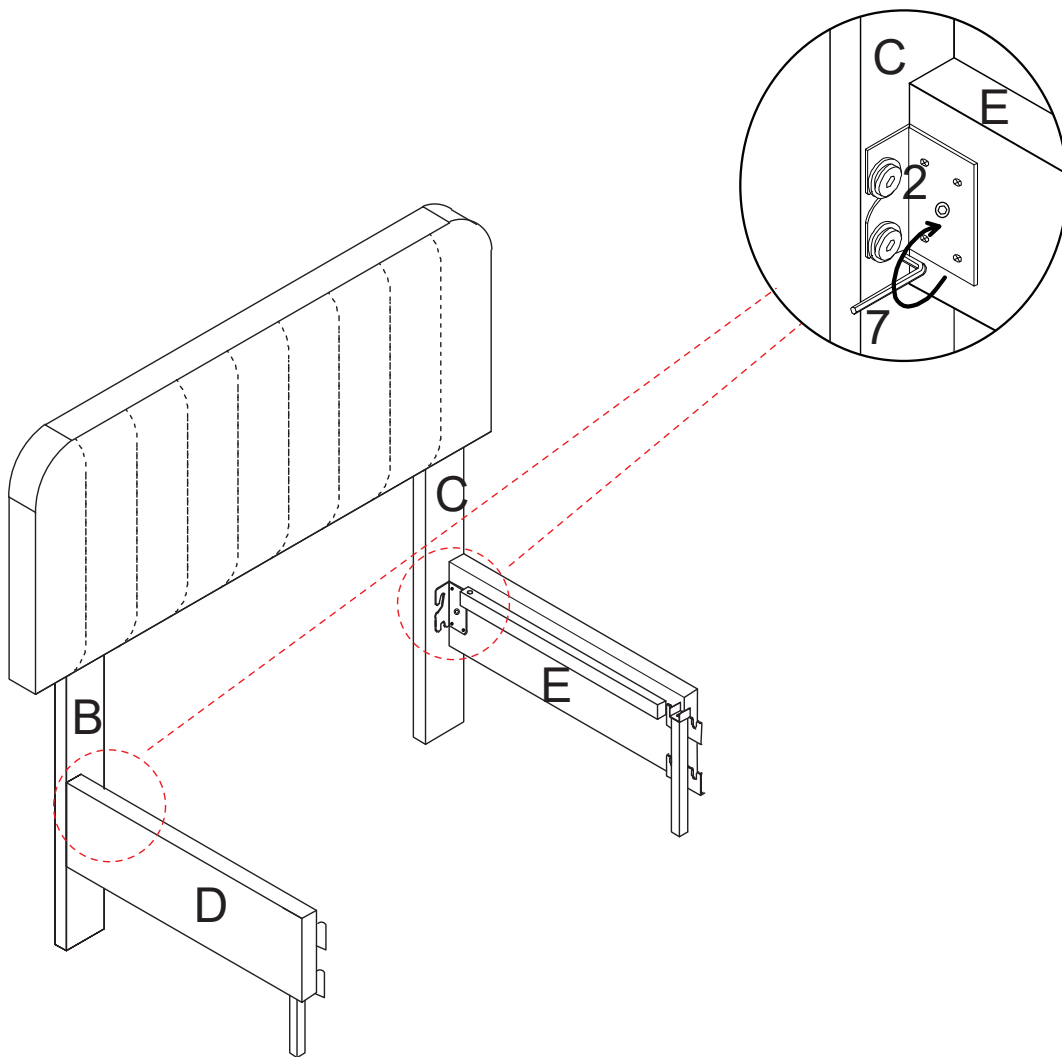

# Step 4

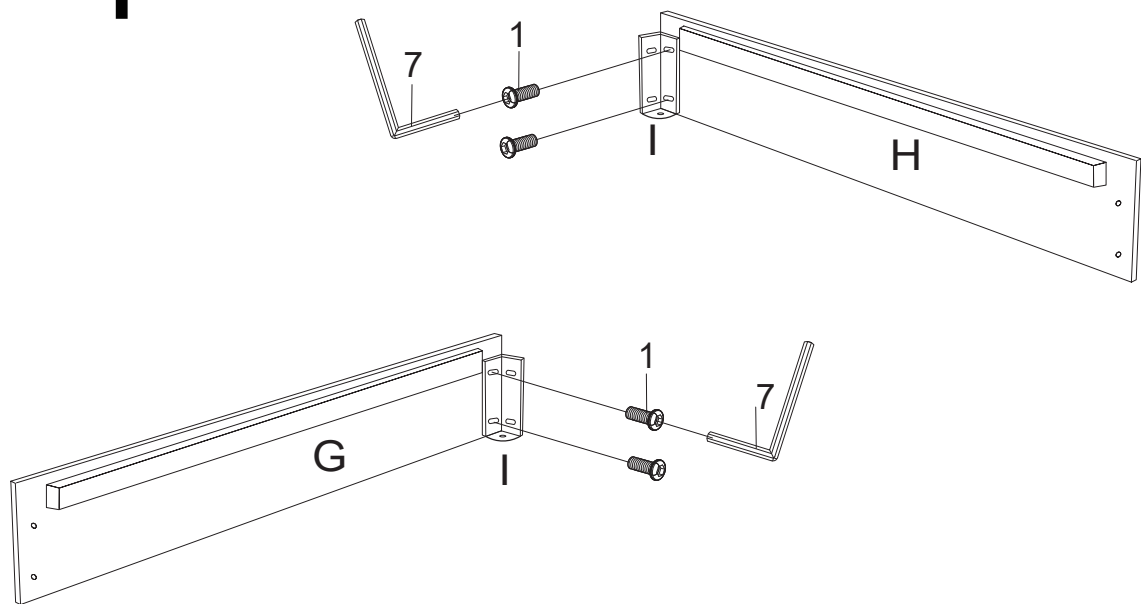

Attach I to G with screw number 1 (tighten with Allen wrench #7). Then, connect the assembly (G with I attached) to J. Repeat the same process for H (attach I to H, then connect it to J).

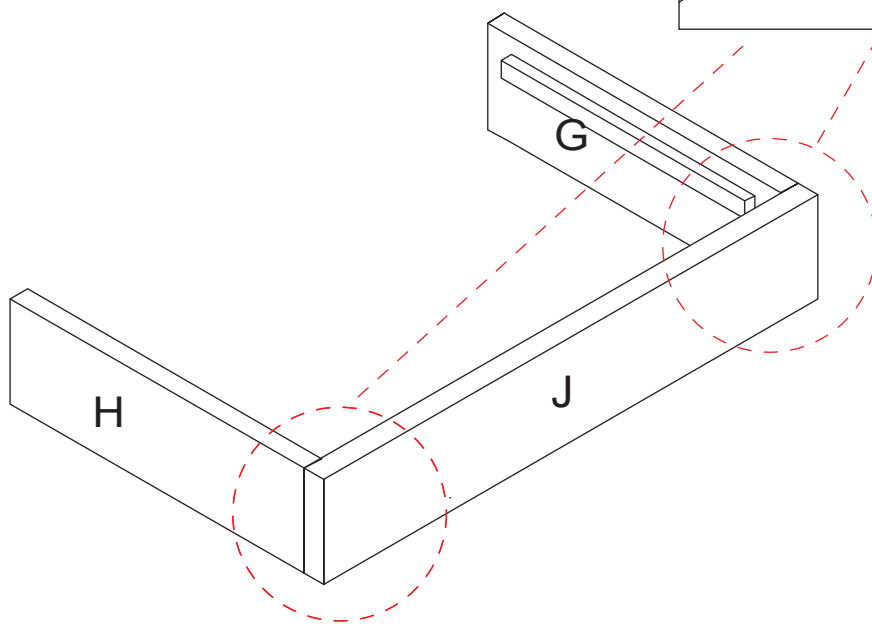
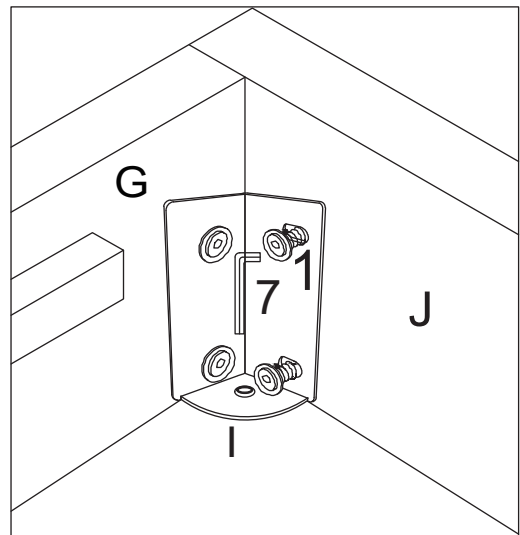

# Step 5

Attach the pad M to the leg L, then screw leg L to part I, with washer K in between.

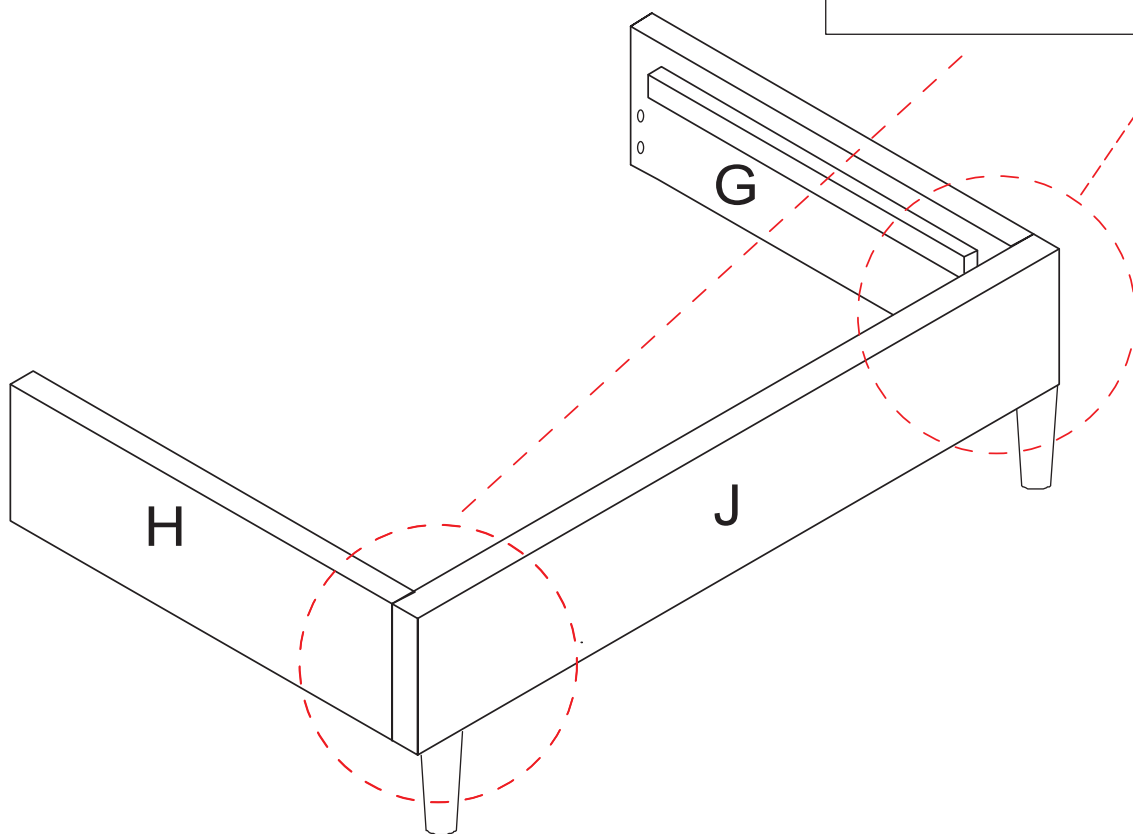
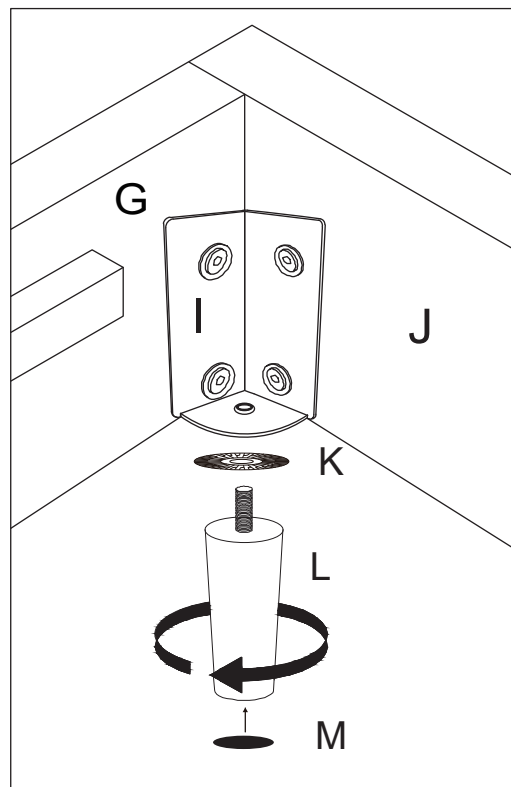

# Step 6

Align part G with connector F (already attached to E) and secure with screws number 1. Repeat the process to align part H with connector F (already attached to D) and secure with screws number 1.

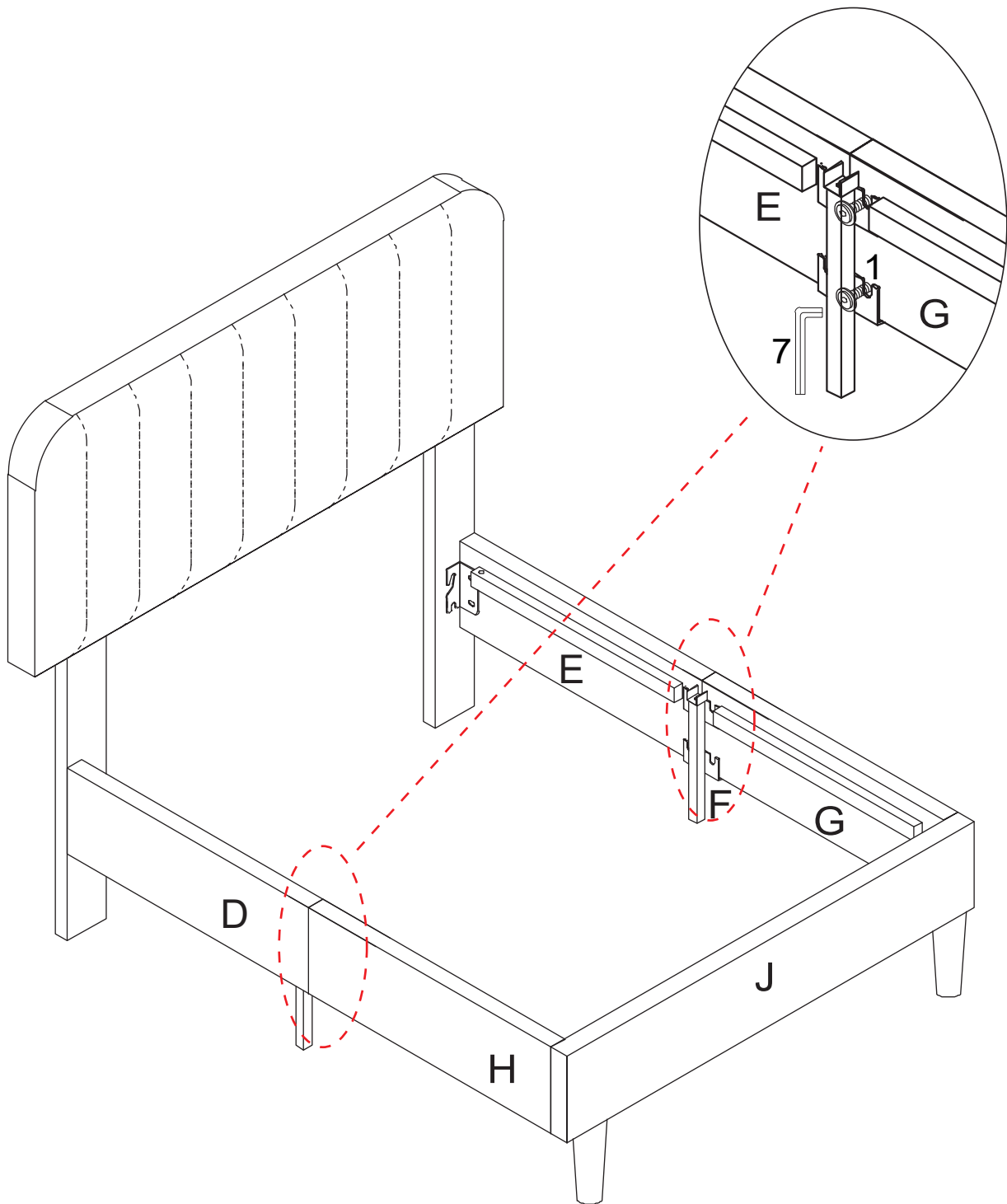

# Step 7

Tighten the screws on one side to 70%, then tighten the screws on the other side to 100%. Finally, tighten all screws on both sides to 100%.

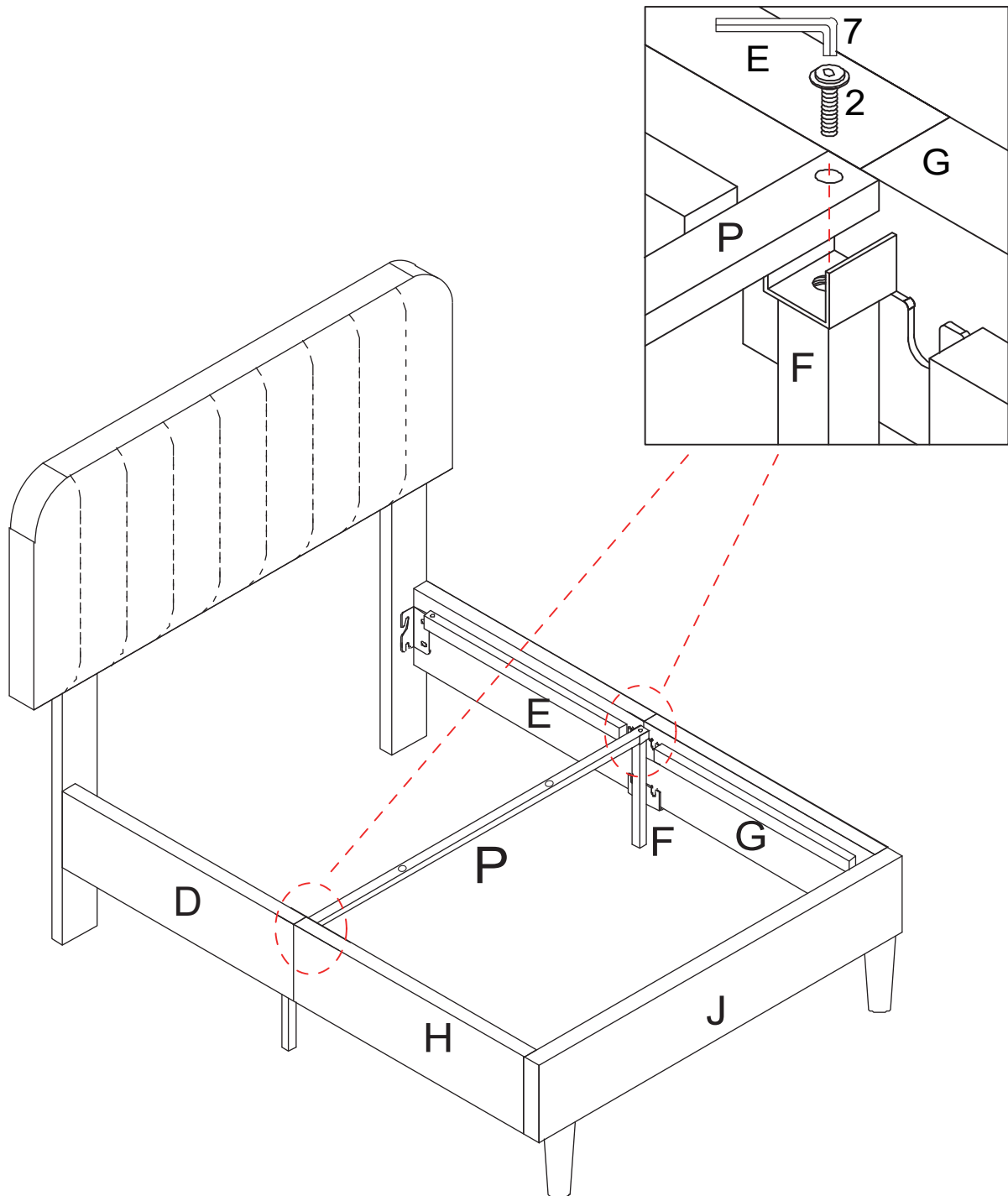

# Step 8

- Connect part Q to part P using screw (number 3).
- Connect part O to part Q using screw (number 2).
- Connect the other end of part O to part J using screw (number 1).
- Connect and tighten part N to part Q using screw (number 2).

