

Assembly Instructions

Caution: You must read this before you proceed

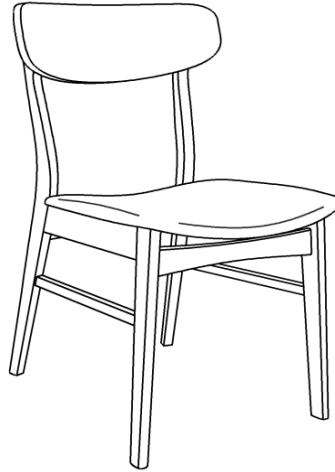



Dining Chair





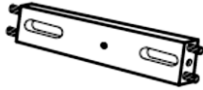
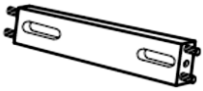

Warning: These chairs are intended only for normal use with all four legs on the ground. These chairs have relatively thin legs and are not designed to be sat in with only two legs on the ground (as from tipping back, forward, or to the side), and such can cause stress and failure of one or more of the legs. Any misuse of the chairs voids any warranties, expressed or implied.

Part List

Label	Picture	Description	QTY
A	A line drawing of the chair back, showing the curved top and the two vertical supports.	Chair Back	1
B	A line drawing of the front leg, showing the vertical post and the horizontal crossbar.	Front Leg	1

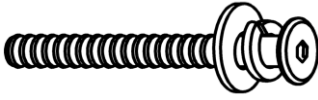
C		Side Stretcher (L)	1
D		Side Stretcher (R)	1
E		Side Rail (L)	1
F		Side Rail (R)	1
G		Cushion Seat	1

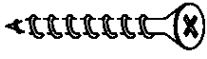
Hardware

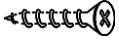
Label	Picture	Description	QTY
①		JCBC M6 x 50mm + S/W M6 + F/W M6 x 13mm	5
②		Allen Key M4	1
③		FH Screw M4*50mm	5
④		L Bracket	5
⑤		Csk Screw M4x16mm	9
⑥		Screwdriver	Not Provided

Assembly Preparation

Before Beginning Assembly:

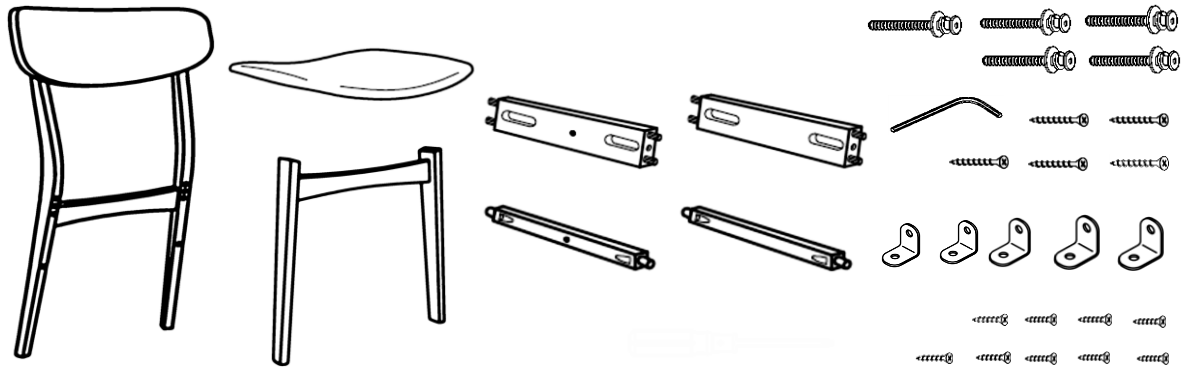

- Read instructions, cover to cover-



- Have 2 adults on hand for assembly-



- Do not assemble on flooring or carpet-



- Assemble on a clean non-marring surface (packing foam)-



- Save all packaging until finished-

Assembly Steps

Overview

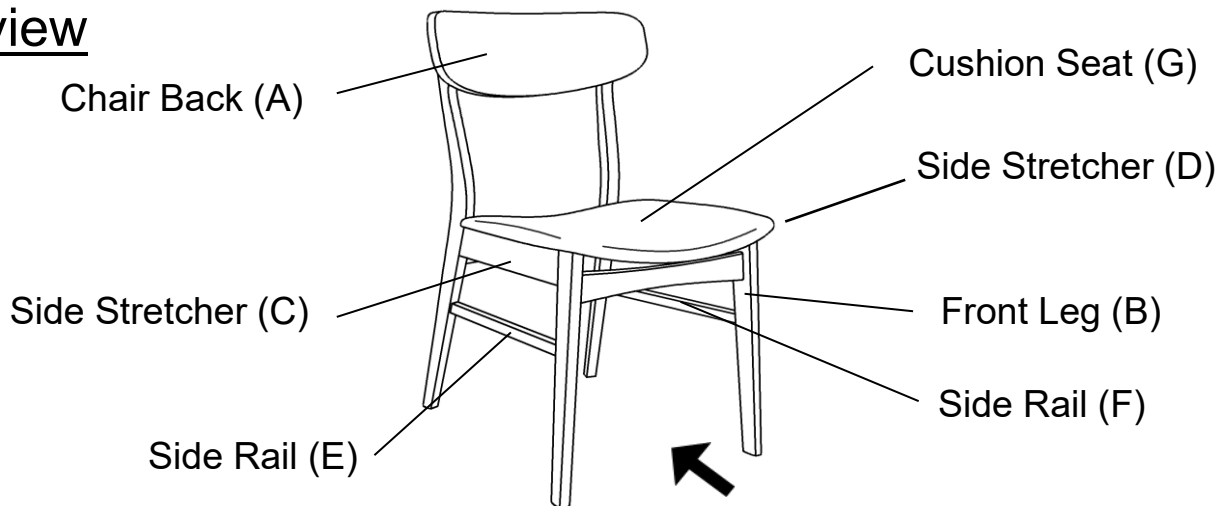

This Dining Chair has multiple parts and may require up to some 30 minutes to assemble. To give you an overview of the Dining Chair parts, the above picture is to help you put the various parts into perspective. Please read through the instructions below to familiarise yourself with the parts and steps before assembly.

Step 1

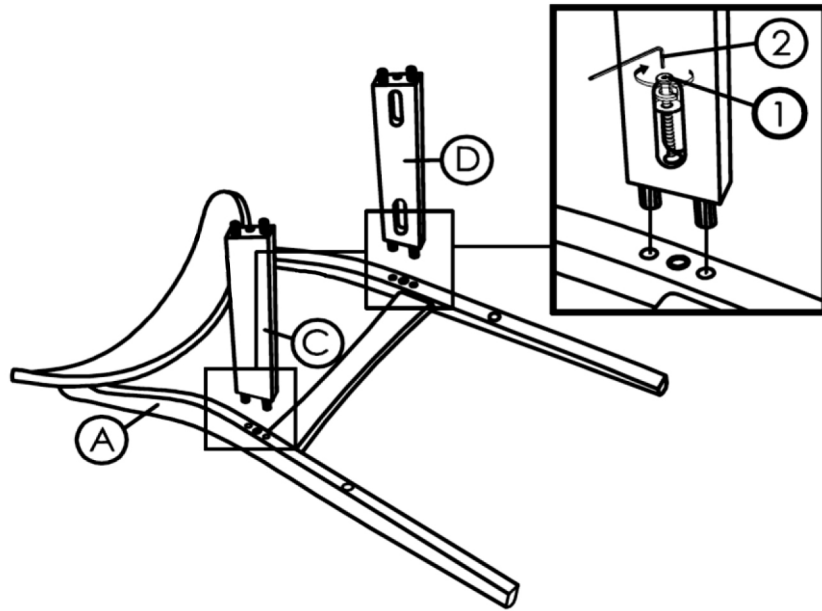

1.1) Insert the Side Stretcher(C) and Side Stretcher(D) into the Chair Back(A) as shown.

Note: Side Stretcher(C) has a small hole for identification.

1.2) Attach Side Stretcher(C) and Side Stretcher(D) to Chair Back(A) using Bolts(①) with Allen Key(②).

Do not fully tighten the Bolts.

Step 2

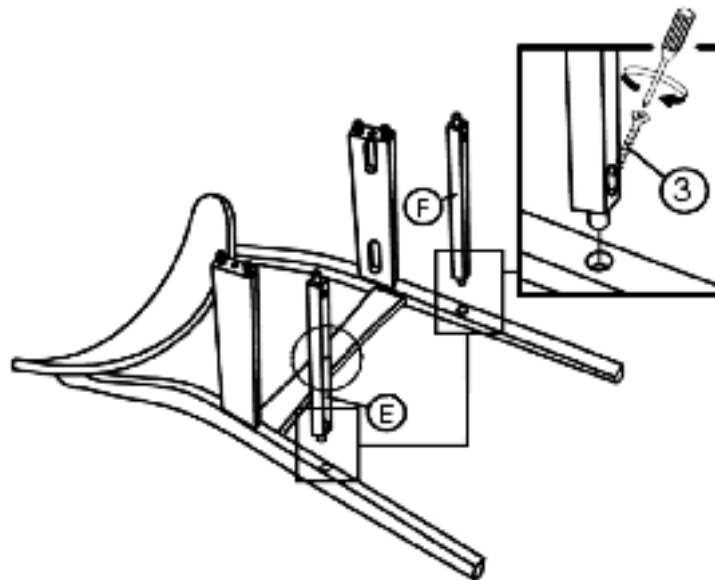

2.1) Insert the Side Rail(E) and Side Rail(F) into Chair Back(A).

Note: Side Rail(E) has a small hole for identification.

2.2) Attach Side Rail(E) and Side Rail(F) to Chair Back(A) using Screws(③) with Screwdriver(⑥).

Do not fully tighten the Screws.

Step 3

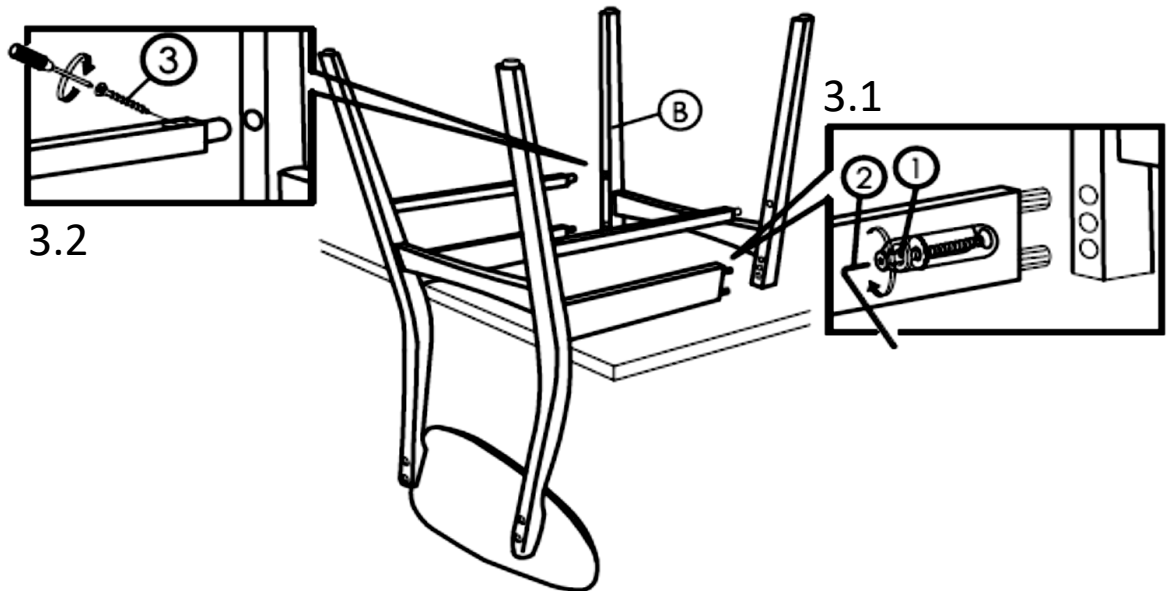

Insert Front Leg(B) onto the Side Stretchers and Side Rails as shown.

3.1) Attach Front Leg(B) to Side Stretchers using Bolts(①) with Allen Key(②).

3.2) Attach Front Leg(B) to Side Rails using Screws(③) with Screwdriver(⑥).

Do not fully tighten the Bolts or Screws.

Step 4

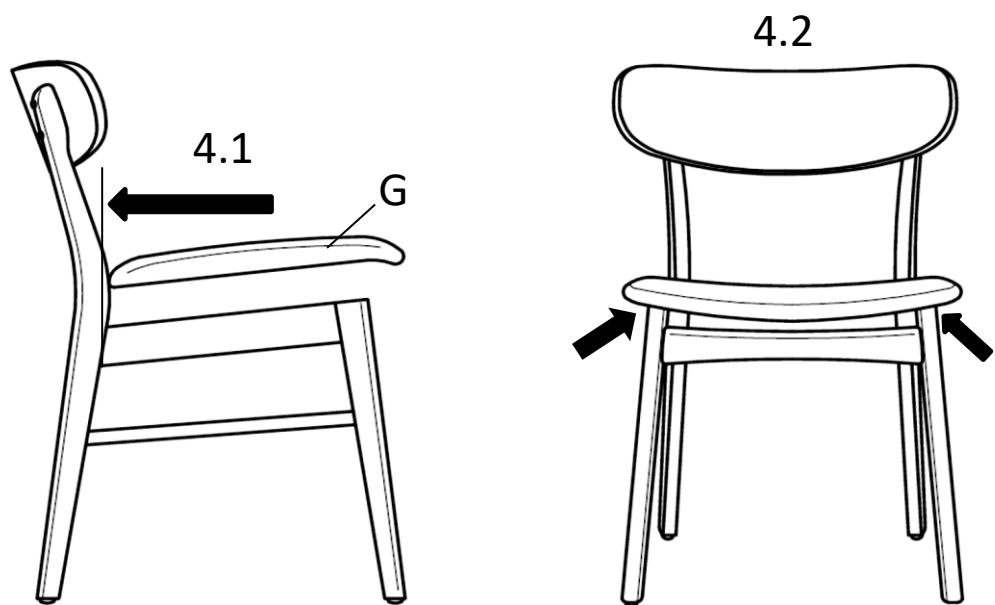

4.1) Align the Cushion Seat(G) to Chair Back(A) as pictured.

4.2) Then, ensure the Cushion Seat(G) is centered using the front view, as shown.

Step 5

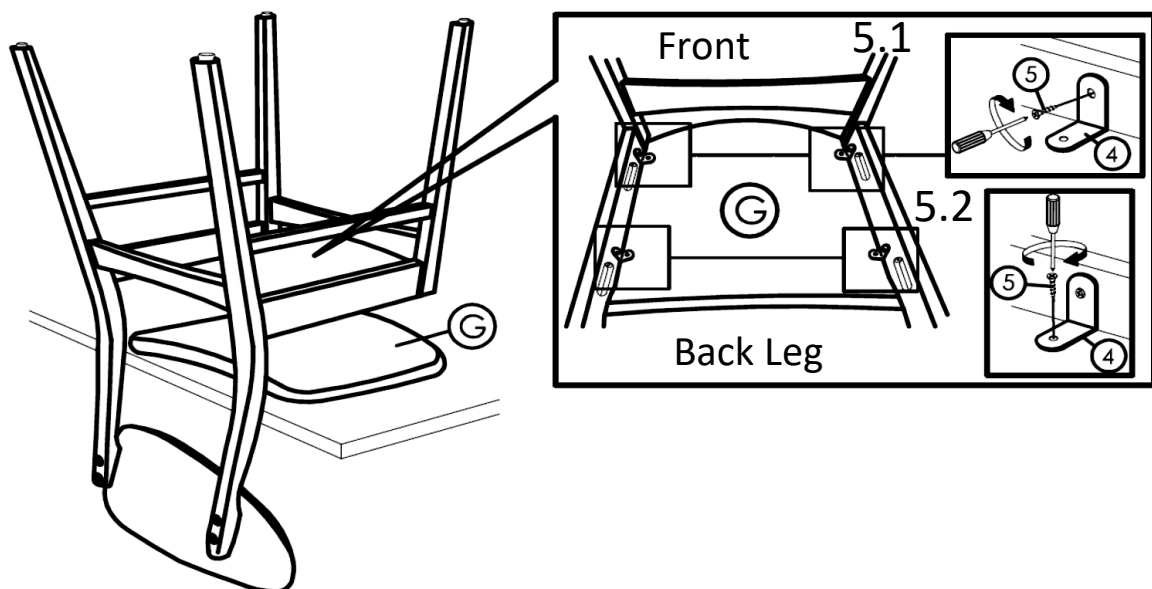

Place the Chair on the edge of a table as shown.

5.1) Attach L-Brackets(4) to Side Stretchers using Screws(5) with Screwdriver(6).

5.2) Attach L-Brackets(4) to Cushion Seat(E) using Screws(5) with Screwdriver(6).

Do not fully tighten the Screws.

Step 6

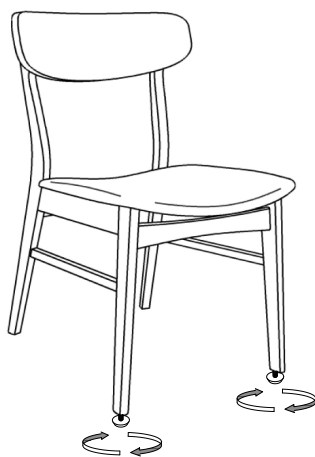

Place the Dining Chair on a Level Surface to check for wobbles.
If it wobbles lift the Dining Chair some 30mm to 50mm high from the ground, keep your feet and toes well away from the drop zone, and drop the Dining Chair freely and vertically with the four legs, hitting the ground at the same time.
This Drop Test will help ensure that all parts and gaps reach full alignment status.
Test again for evenness on a Level Surface.
If no wobbles are found, proceed to tighten all Bolts and Screws in a sequential manner.
When tightening the Bolts, tighten sequentially.
Do not tighten any Bolt or Screw fully and then move on towards the next one, this could cause the frame to warp.
If it still wobbles, loosen the Bolts and execute this same drop test.
If the Dining Chair is not Stable it could lead to damage to the product.

Step 7



Inspect and make sure all parts are connected.
Your Dining Chair is ready for use.
This Dining Chair can only be used on a flat, level surface.

Care & Maintenance



- Furniture may scratch floors. We recommend using furniture pads to protect your floors.



- Do not put hot items directly on furniture surface.



- Do not clean furniture with harsh cleansers or polish.



- Do not place furniture under direct sunlight.



- Do not place furniture near heating or cooling vents.



- Do not write on furniture without a padded barrier to protect the surface.



- Do not place furniture outside . For indoor use only.



- Not for commercial use. For residential use only.



- Stains may be removed with mild soap solution and damp cloth.



- Children should not climb or jump on the furniture.



- Dust and pick-up spills using a clean, non-colored, lint-free cloth.