

# Assembly Instruction

---

## Coffee table

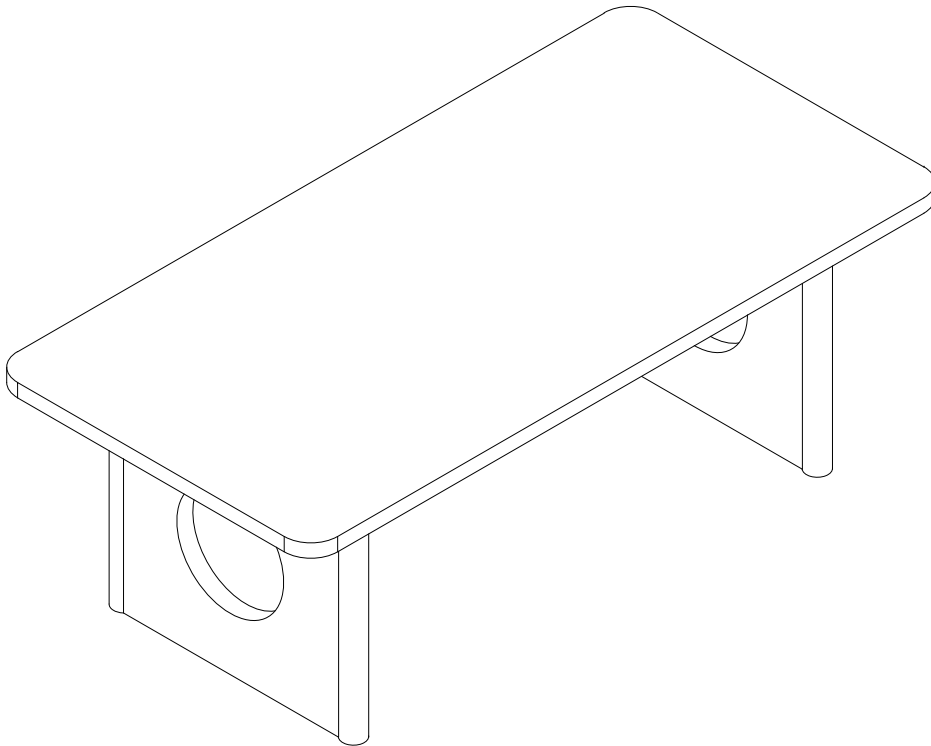

---



### ASSEMBLY TIPS:

1. Remove hardware from box and sort by size.
2. Please check to see that all hardware and parts are present prior to start of assembly.
3. Please follow attached instructions in the same sequence as numbered to assure fast & easy assembly.

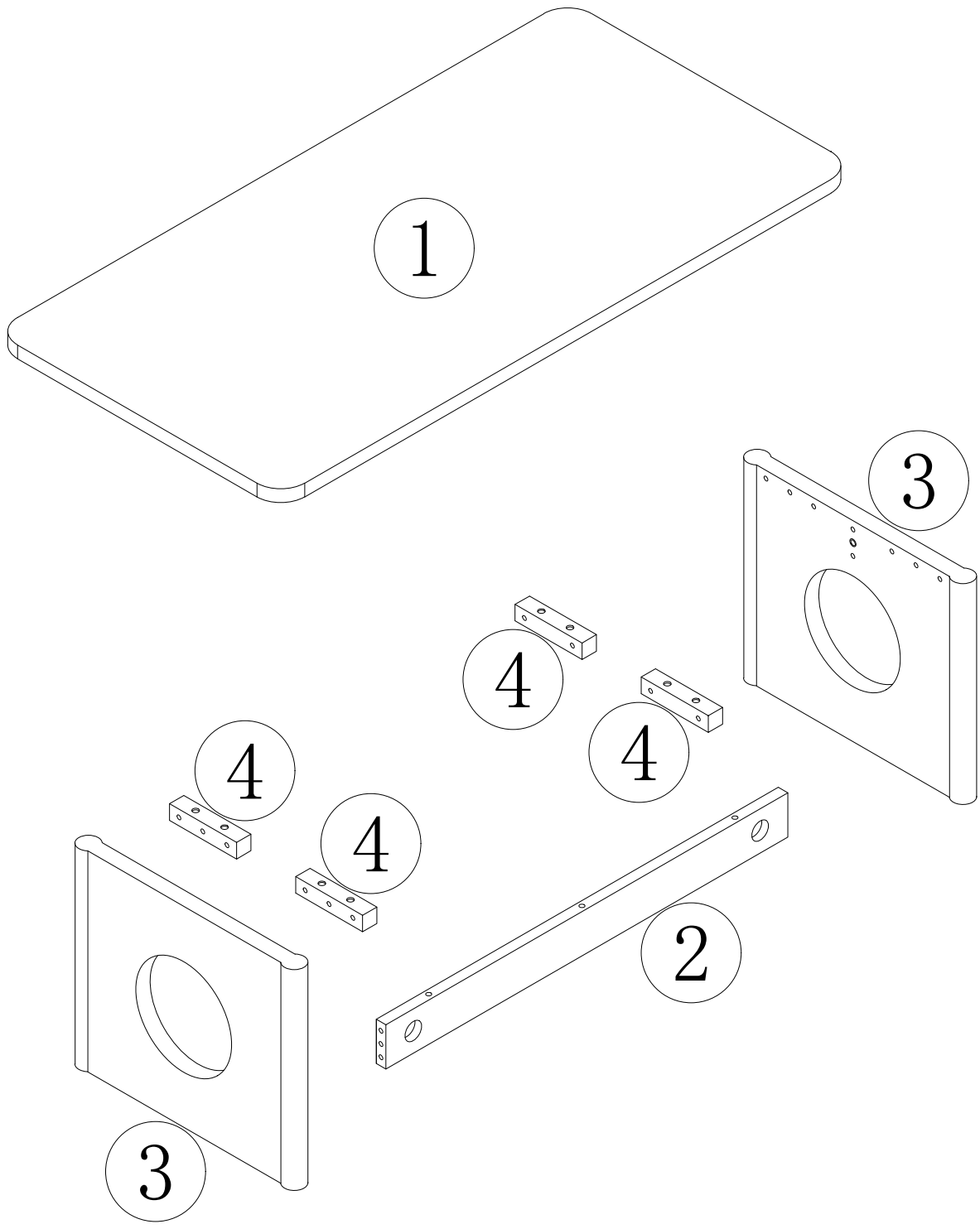



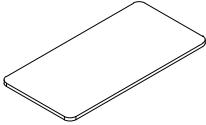
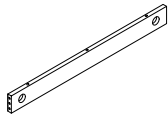
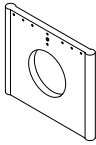







# Parts List



# Parts List



Number	Name	Part	Qty
1	Table top		x1PC
2	Shelf brace		x1PC
3	Leg		x2PCS
4	Connect the wooden blocks		x4PCS

# Hardware List

Number	Hardware	Part	Qty
A	8X90		x3+1PC
B	8X30		x8+2PCS
D	Ø8x30		x10+2PCS
E			x11+4PCS
F			x11+4PCS
M			x2+1PC
N			x2+1PC
O			x2+1PC
P			x1PC
Q	4X40		x8+2PCS
S	M4		x1PC
T			x4PCS

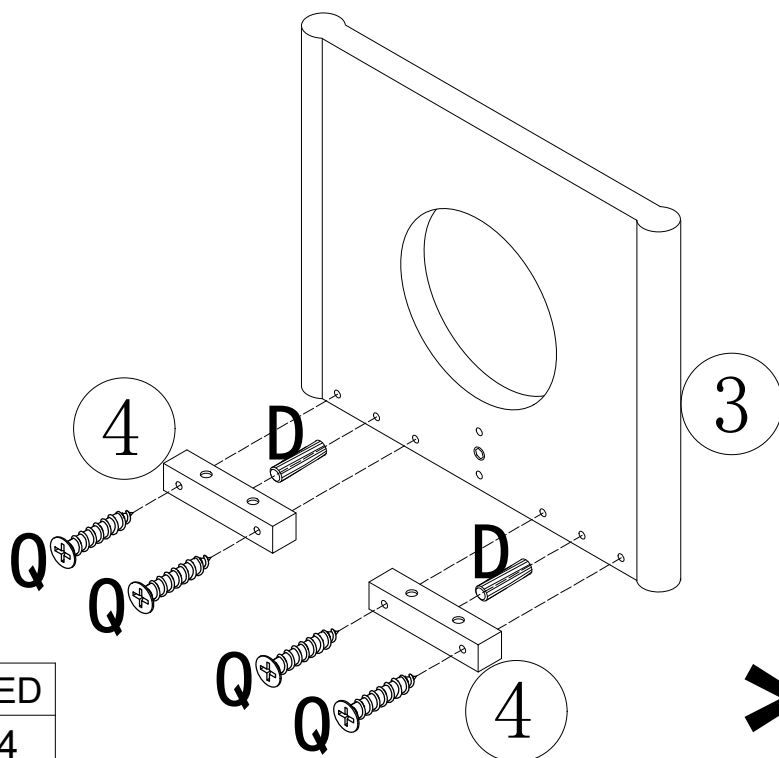
1





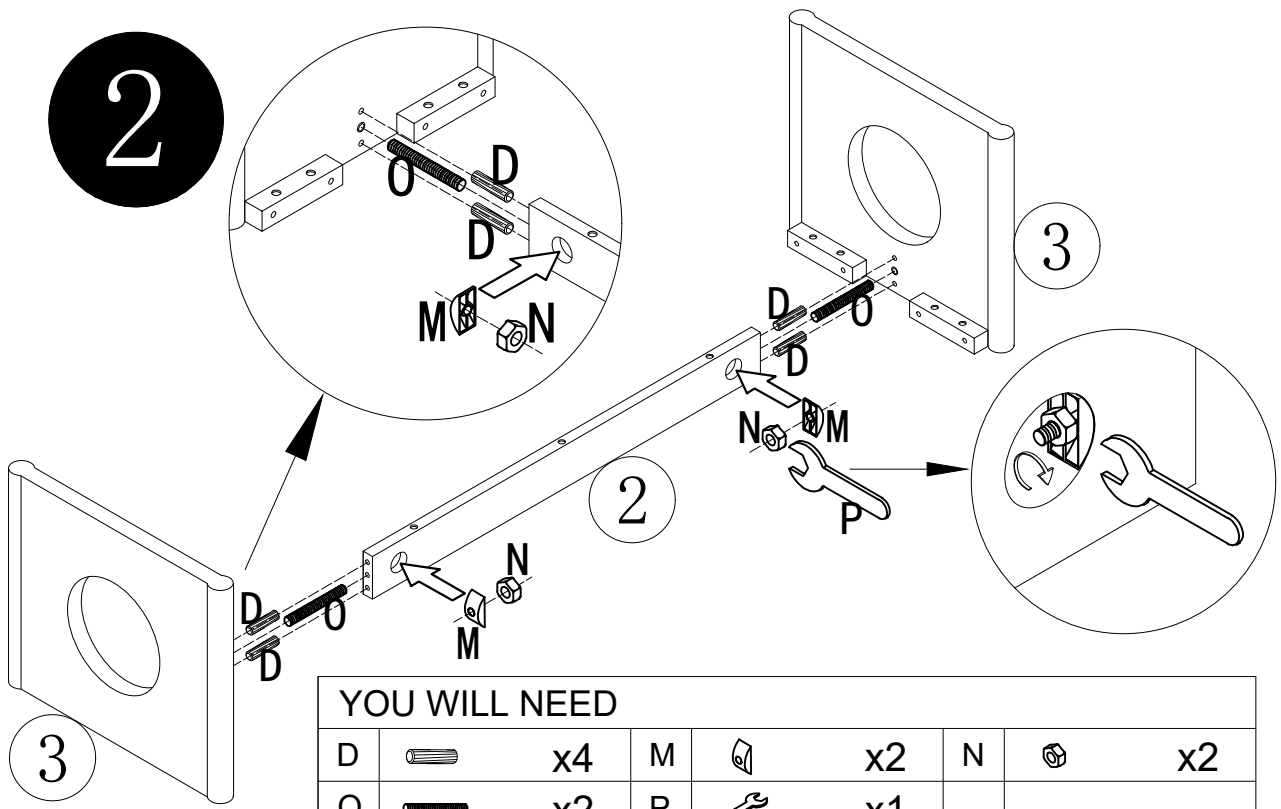

YOU WILL NEED		
D		x4
Q		x8

\*2



2

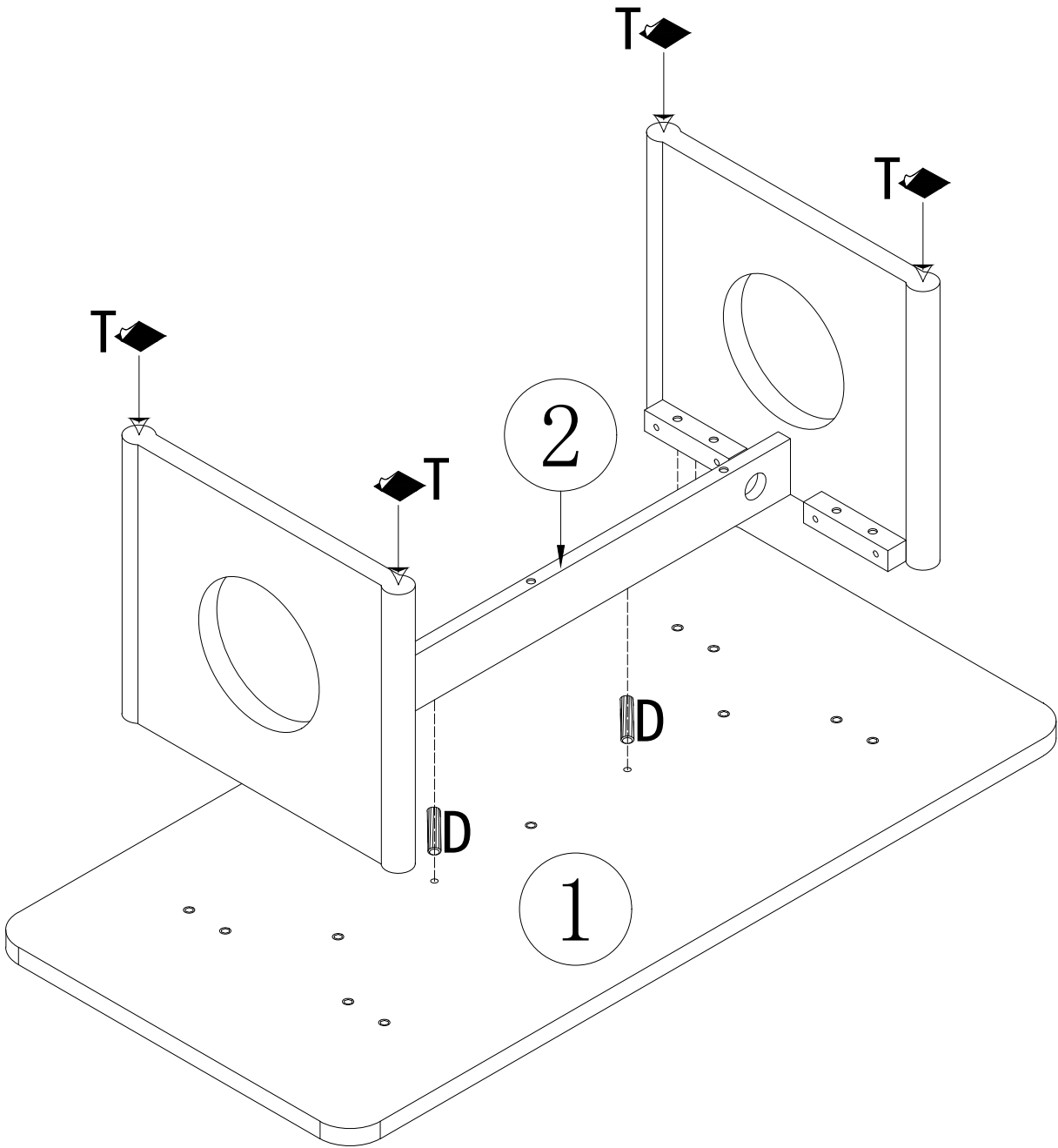

YOU WILL NEED					
D		x4	M		x2
O		x2	P		x1
			N		x2

3



YOU WILL NEED		
D		x2
T		x4

4

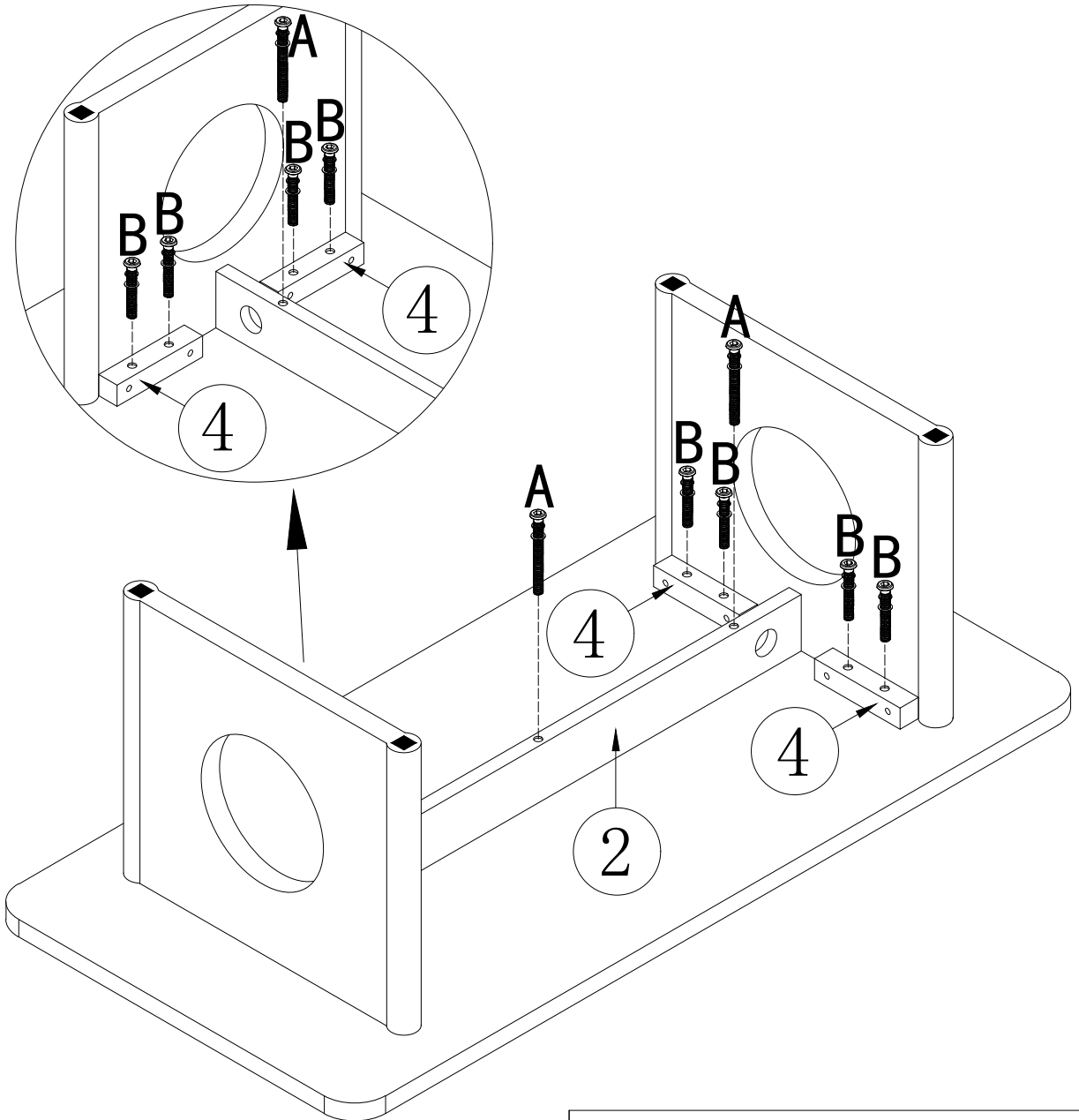
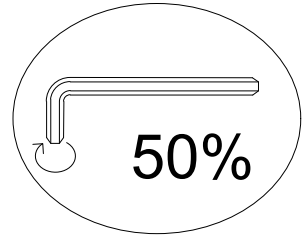
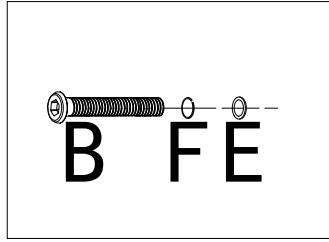
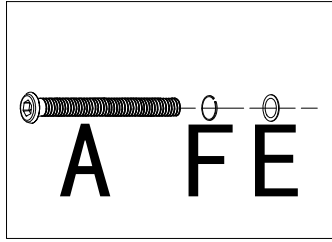

YOU WILL NEED					
A		x3	F		x11
B		x8	S		x1
E		x11			

5

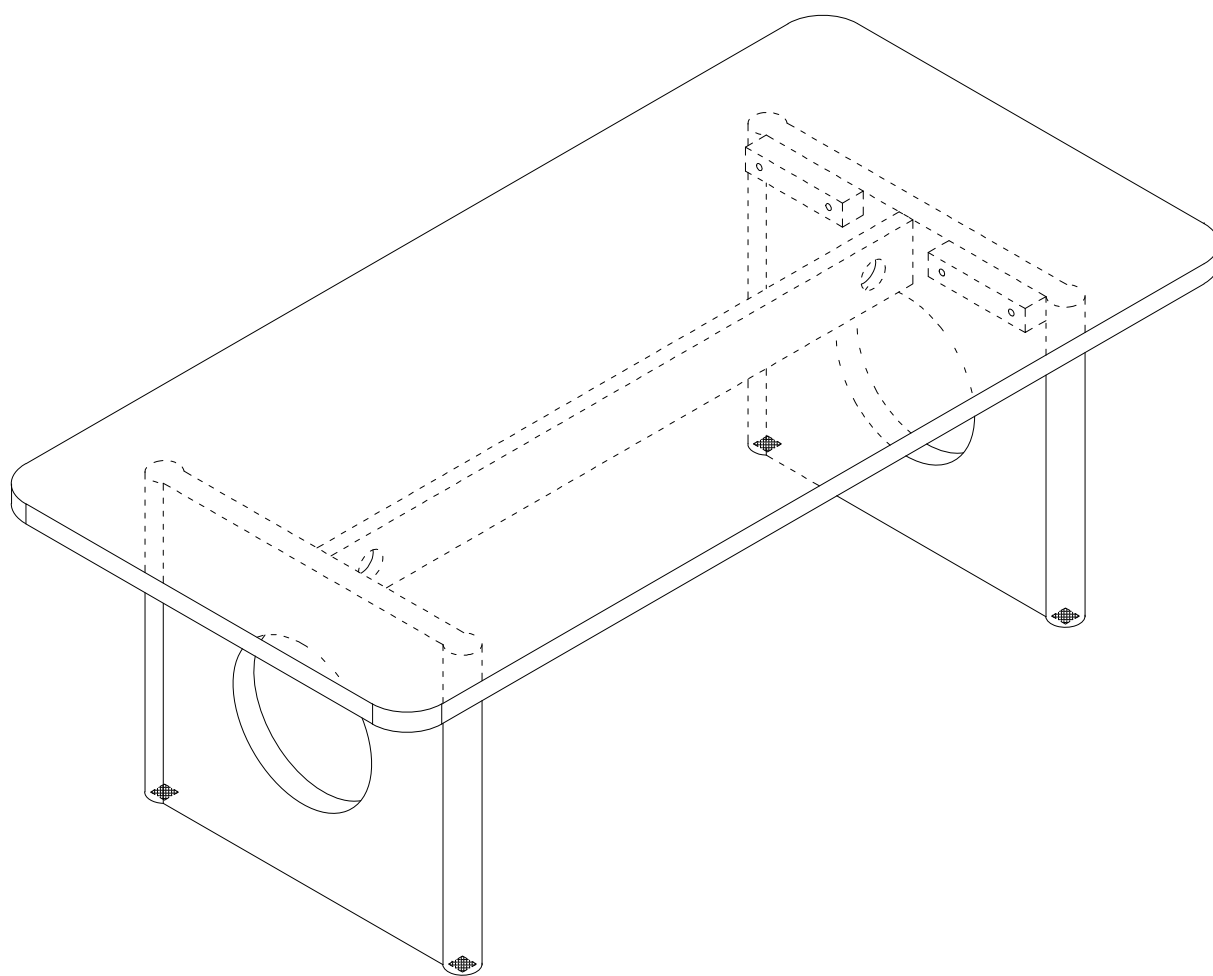
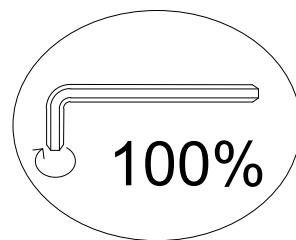

Please ensure that all screws are tightened