

Care & Maintenance



- Furniture may scratch floors. We recommend using furniture pads to protect your floors.



- Do not put hot items directly on furniture surface.



- Do not clean furniture with harsh cleansers or polish.



- Do not place furniture under direct sunlight.



- Do not place furniture near heating or cooling vents.



- Do not write on furniture without a padded barrier to protect the surface.



- Do not place furniture outside . For indoor use only.



- Not for commercial use. For residential use only.



- Stains may be removed with mild soap solution and damp cloth.



- Children should not climb or jump on the furniture.



- Dust and pick-up spills using a clean, non-colored, lint-free cloth.

ASSEMBLY INSTRUCTIONS

FULL BED
SKU CODE: 70840.00-F

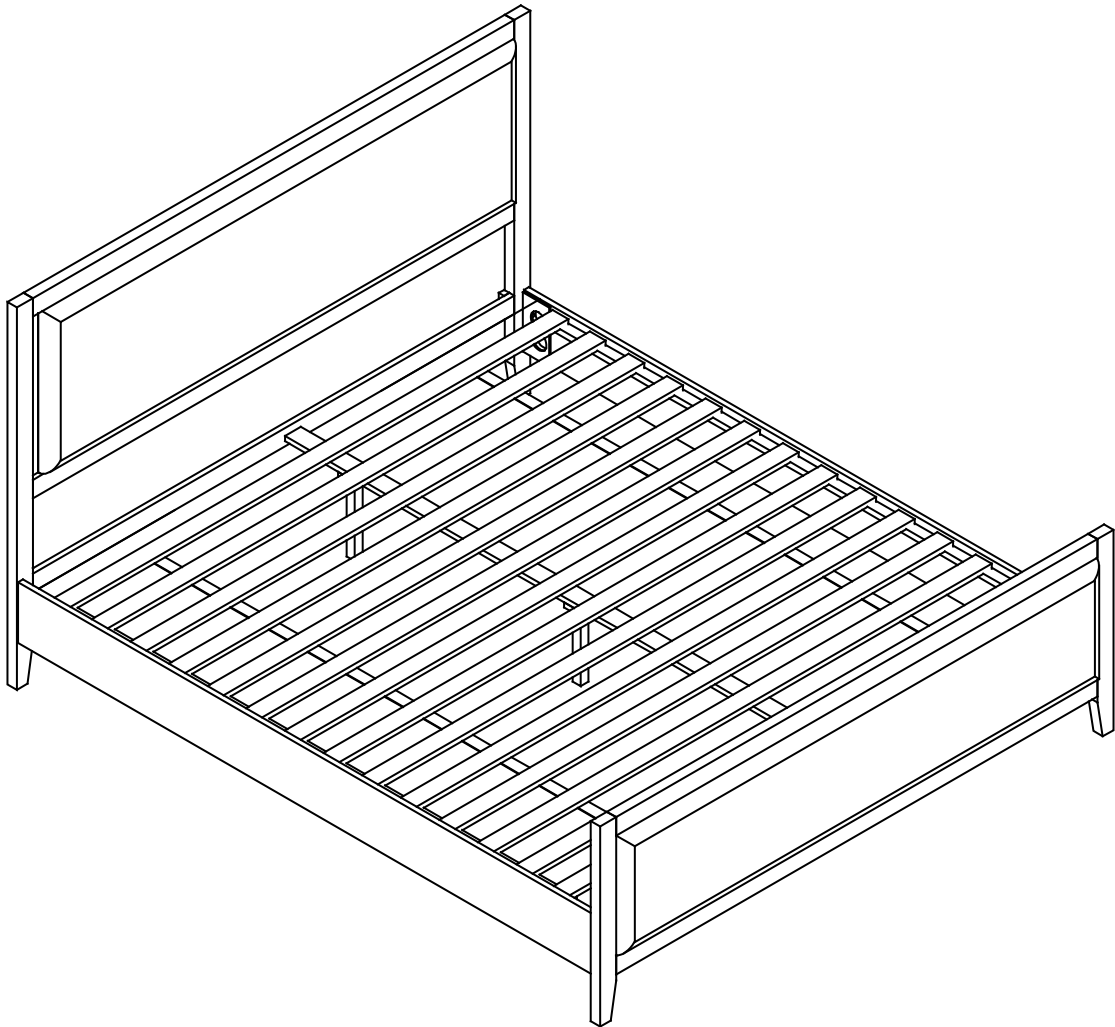



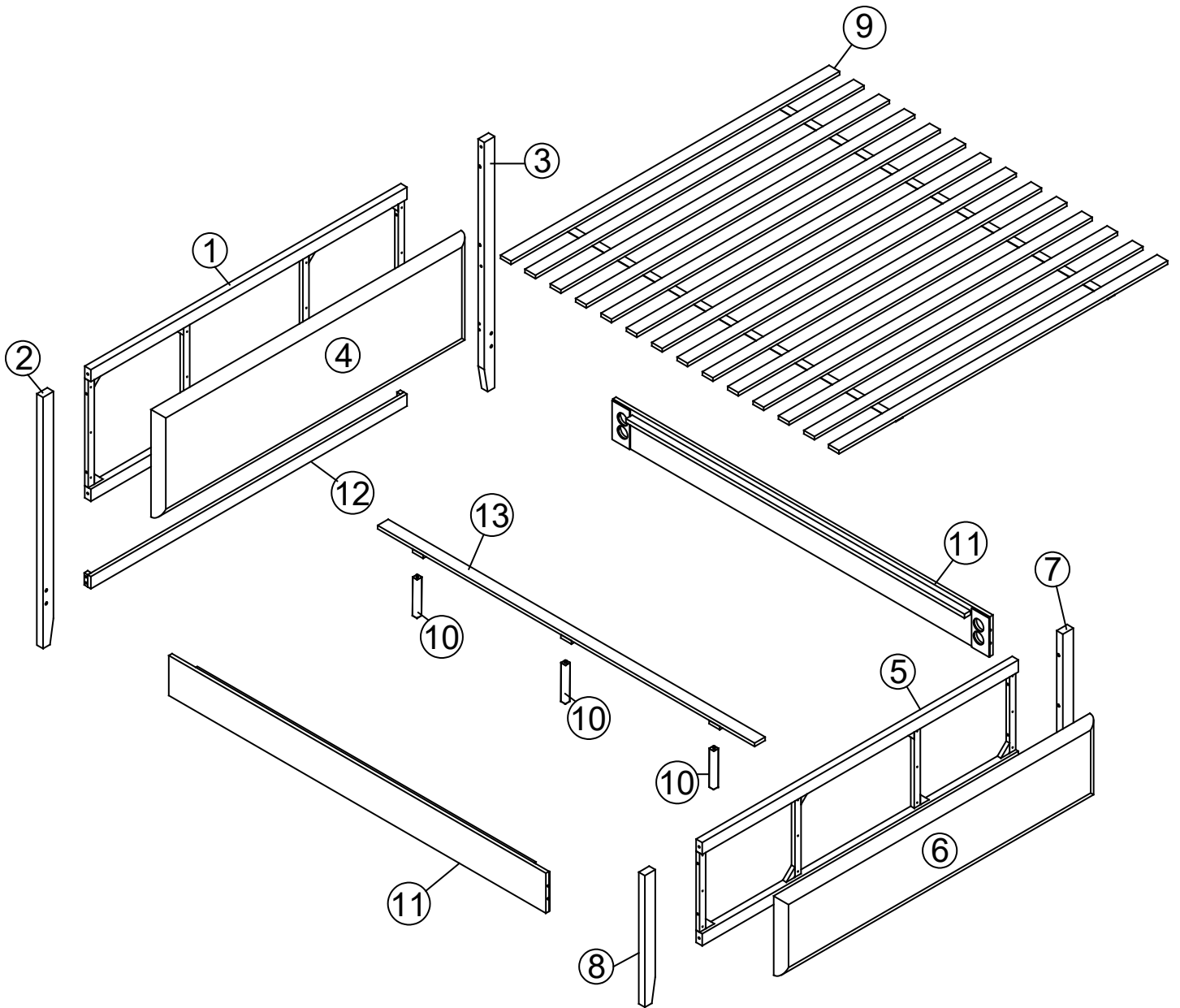

Detail View



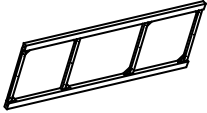
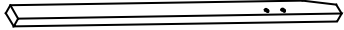
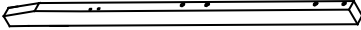

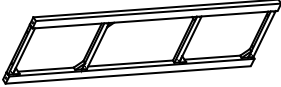
Part List

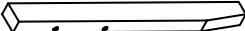
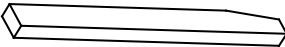
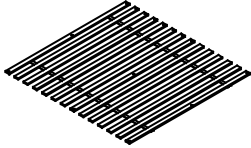
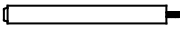





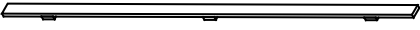



70840.00-F-H

<p>① x 1 PC</p>  <p>Frame Headboard</p>	<p>② x 1 PC</p>  <p>Left Headboard Leg</p>
<p>③ x 1 PC</p>  <p>Right Headboard Leg</p>	<p>④ x 1 PC</p>  <p>Headboard Mattress</p>
<p>⑤ x 1 PC</p>  <p>Panel Footboard</p>	<p>⑥ x 1 PC</p>  <p>Footboard Mattress</p>
<p>⑦ x 1 PC</p>  <p>Right Footboard Leg</p>	<p>⑧ x 1 PC</p>  <p>Left Footboard Leg</p>
<p>⑨ x 1 PC</p>  <p>Slat</p>	<p>⑩ x 3 PCS</p>  <p>Support Leg</p>

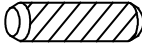
70840.00-F-P + Hardware inside

<p>⑪ x 2 PCS</p>  <p>Side Rails</p>	<p>⑫ x 1 PC</p>  <p>Support Headboard</p>
<p>⑬ x 1 PC</p>  <p>Center support bar</p>	

Hardware List

<p>Ⓐ x 8PCS</p>  <p style="text-align: center;">Ø5/16"x60mm</p> <p style="text-align: center;">Bolts</p>	<p>Ⓑ x 2PCS</p>  <p style="text-align: center;">Ø1/4"x30mm</p> <p style="text-align: center;">Bolts</p>	<p>Ⓒ x 18PCS</p>  <p style="text-align: center;">Ø5/16"x13mm</p> <p style="text-align: center;">Spring Washer</p>
<p>Ⓓ x 10PCS</p>  <p style="text-align: center;">Ø5/16"x19mm</p> <p style="text-align: center;">Flat Washer</p>	<p>Ⓔ x 10PCS</p>  <p style="text-align: center;">Ø10x40mm</p> <p style="text-align: center;">Wood dowel</p>	<p>Ⓕ x 8PCS</p>  <p style="text-align: center;">Ø5/16"x90mm</p> <p style="text-align: center;">Bolts</p>
<p>Ⓖ x 8PCS</p>  <p style="text-align: center;">Ø5/16"</p> <p style="text-align: center;">Hexagon nuts</p>	<p>Ⓗ x 8PCS</p>  <p style="text-align: center;">Ø5/16"</p> <p style="text-align: center;">Curved washers</p>	<p>Ⓖ x 29PCS</p>  <p style="text-align: center;">Ø4x25mm</p> <p style="text-align: center;">Wood screws</p>
<p>Ⓚ x 1PC</p>  <p style="text-align: center;">100*30*4mm</p> <p style="text-align: center;">Allen key</p>	<p>Ⓛ x 1PC</p>  <p style="text-align: center;">Ø5/16"</p> <p style="text-align: center;">Wrench</p>	

ASSEMBLY TOOLS REQUIRED (NOT INCLUDED)

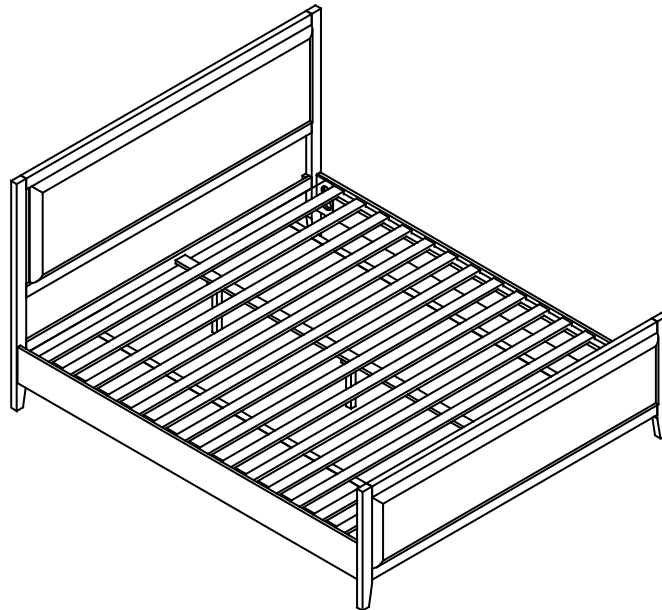
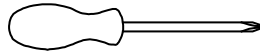

STEP: 1

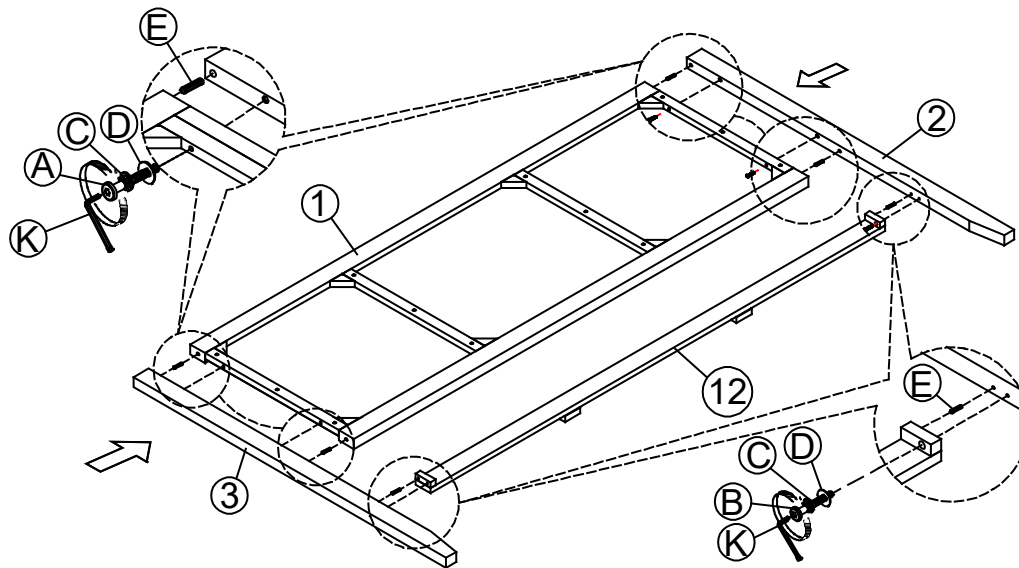

Attach the right headboard leg (3) and left headboard leg (2) to the frame headboard (1) using the bolts (A), spring washers (C), flat washers (D), and wooden dowels (E), Allen key (K) .
Attach the right headboard leg (3) and left headboard leg (2) support headboard (12) using bolts (B), spring washers (C), flat washers (D), and wooden dowels (E), Allen key (K). Tightening the bolts completely at this step

STEP: 2

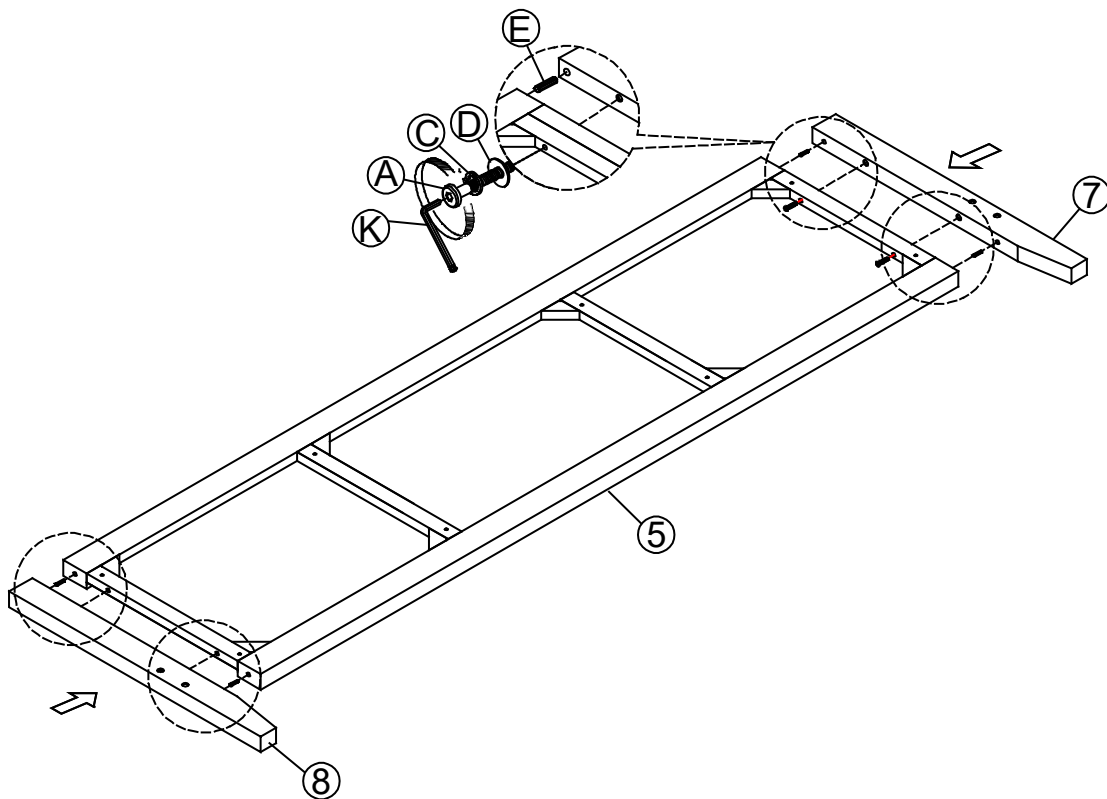

Attach the right footboard leg (7) and left footboard leg (8) to the panel footboard (5) using the bolts (A), spring washers (C), flat washers (D), and wooden dowels (E), Allen key (K) .Tightening the bolts completely at this step

STEP: 3

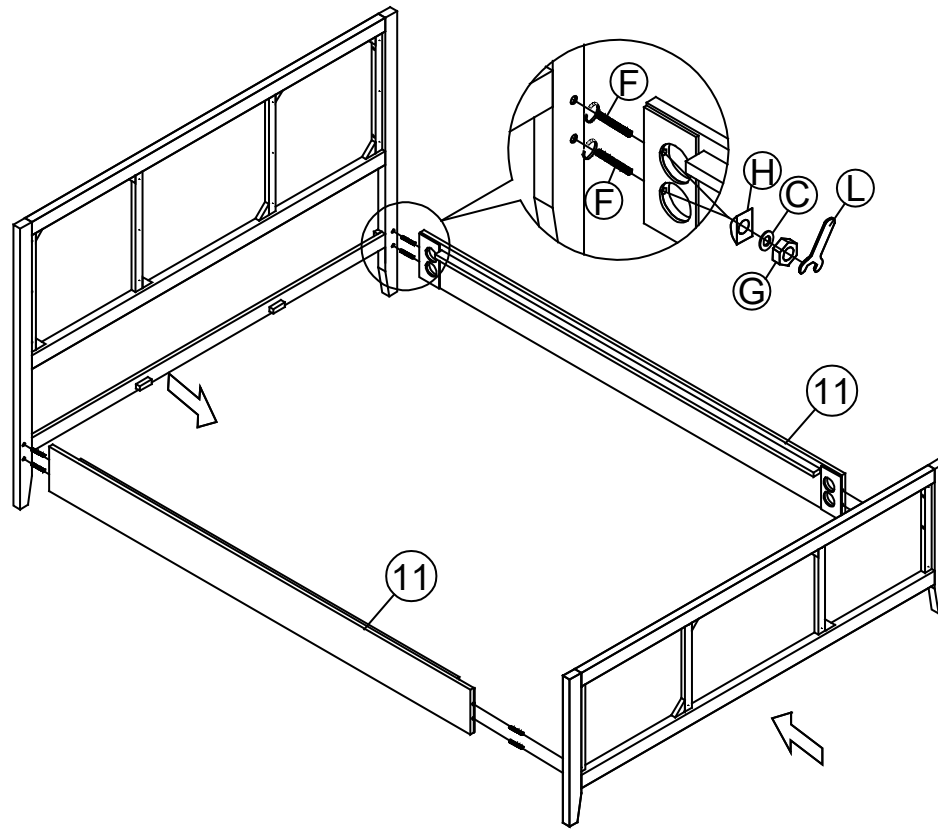

Assemble the siderails (11), to the headboard in step (1), and the footboard in step (2), using bolts (F), curved washers (H), Spring washer (C), Hexagon nuts (G), and Wrench (L). Tighten all nuts in this step.

STEP: 4

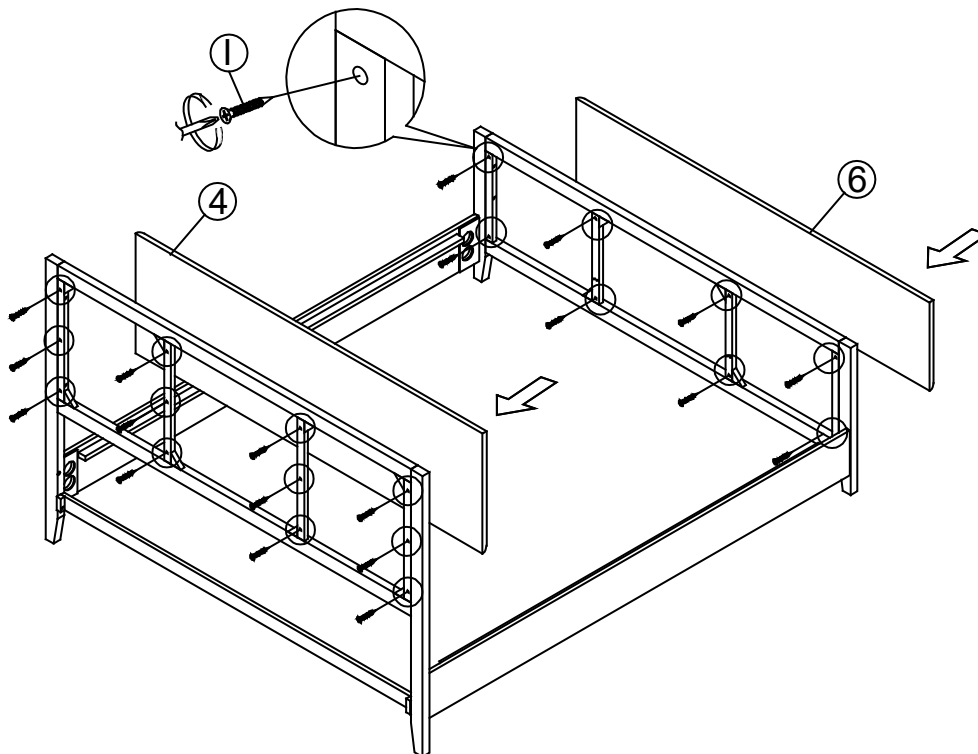

Assemble the headboard mattress (4) into the headboard step (1), assemble the footboard mattress (6), into the footboard step (2), Wood screws (I). Note: do not tighten too hard.

STEP: 5

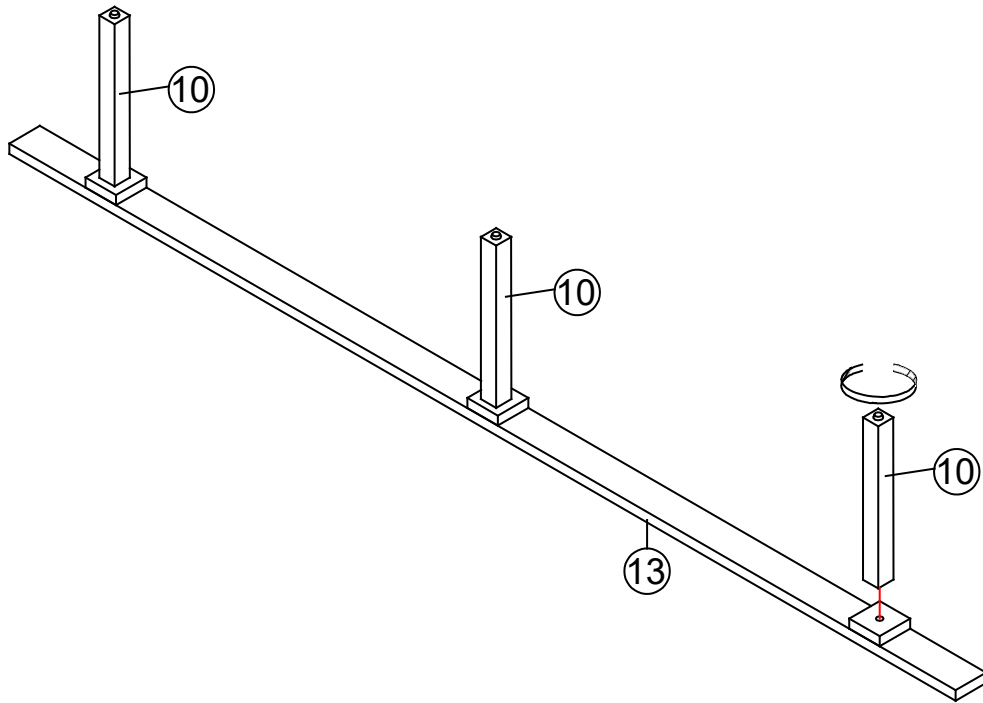

Assemble the support leg (10) into the Center support bar (13)

STEP: 6

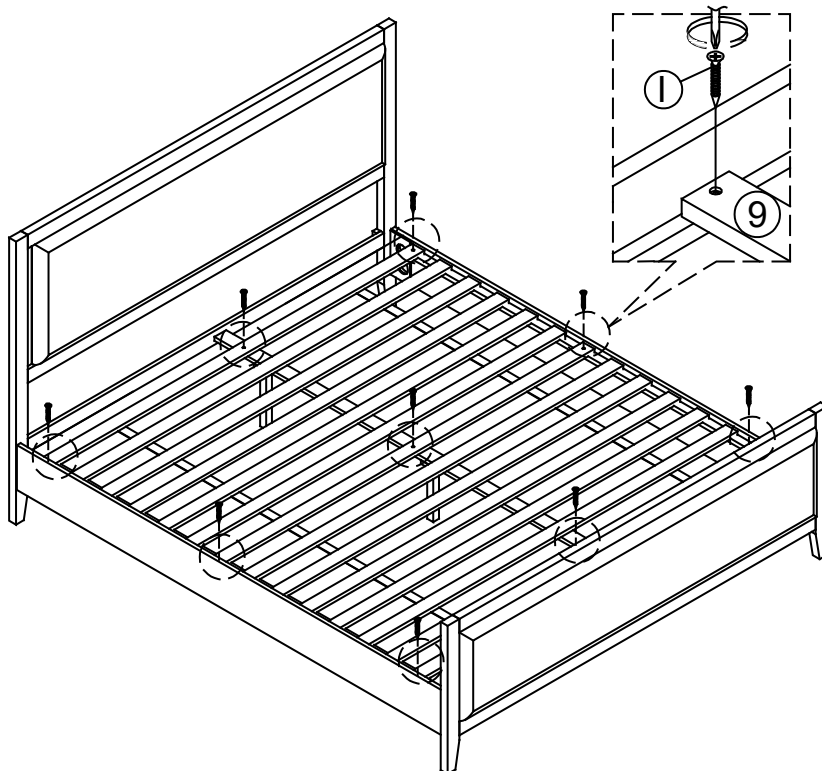

Place the center support bar (13) in the middle then install the slat (9) to the siderails (11) and to the center support bar (13) in step (5) Wood screws (I). Note: do not tighten too hard.

STEP: 7

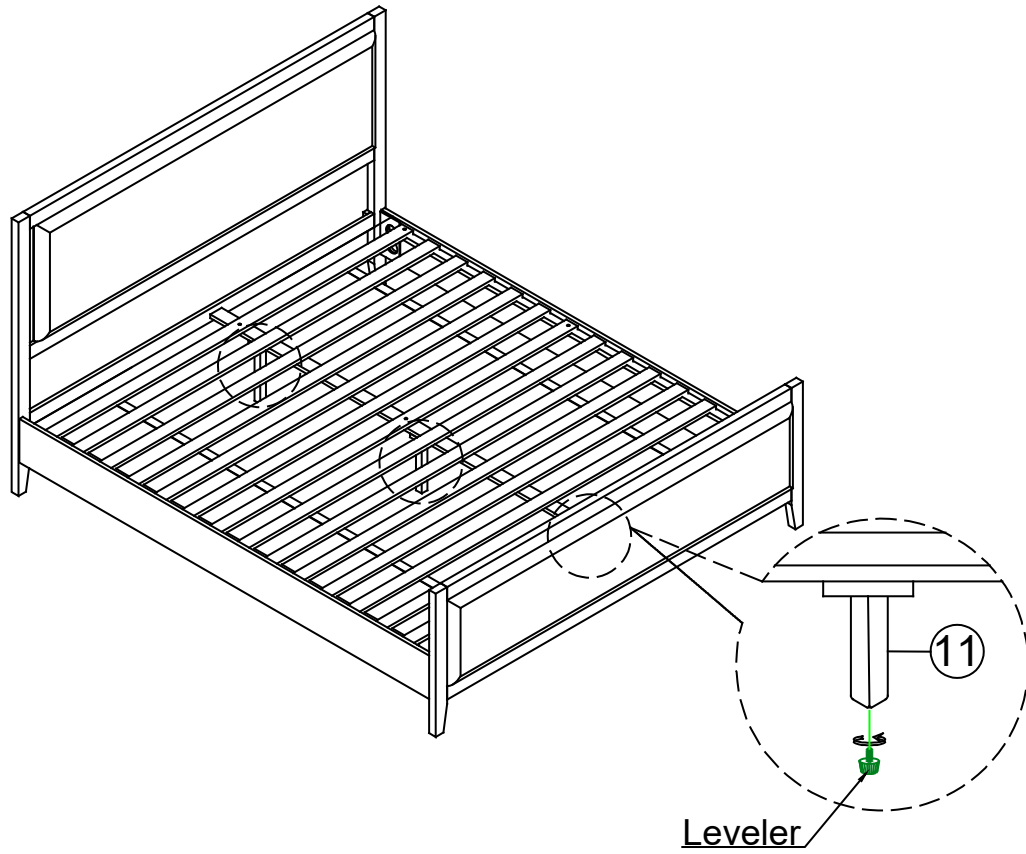

Adjust the leveler high and low to balance

FINAL

