

Care & Maintenance



- Furniture may scratch floors. We recommend using furniture pads to protect your floors.



- Do not put hot items directly on furniture surface.



- Do not clean furniture with harsh cleansers or polish.



- Do not place furniture under direct sunlight.



- Do not place furniture near heating or cooling vents.



- Do not write on furniture without a padded barrier to protect the surface.



- Do not place furniture outside . For indoor use only.



- Not for commercial use. For residential use only.



- Stains may be removed with mild soap solution and damp cloth.



- Children should not climb or jump on the furniture.



- Dust and pick-up spills using a clean, non-colored, lint-free cloth.

ASSEMBLY INSTRUCTIONS

QUEEN BED / KING BED
CALI KING BED

SKU CODE: 70840.00-Q
70840.00-K / 70840.00-CK

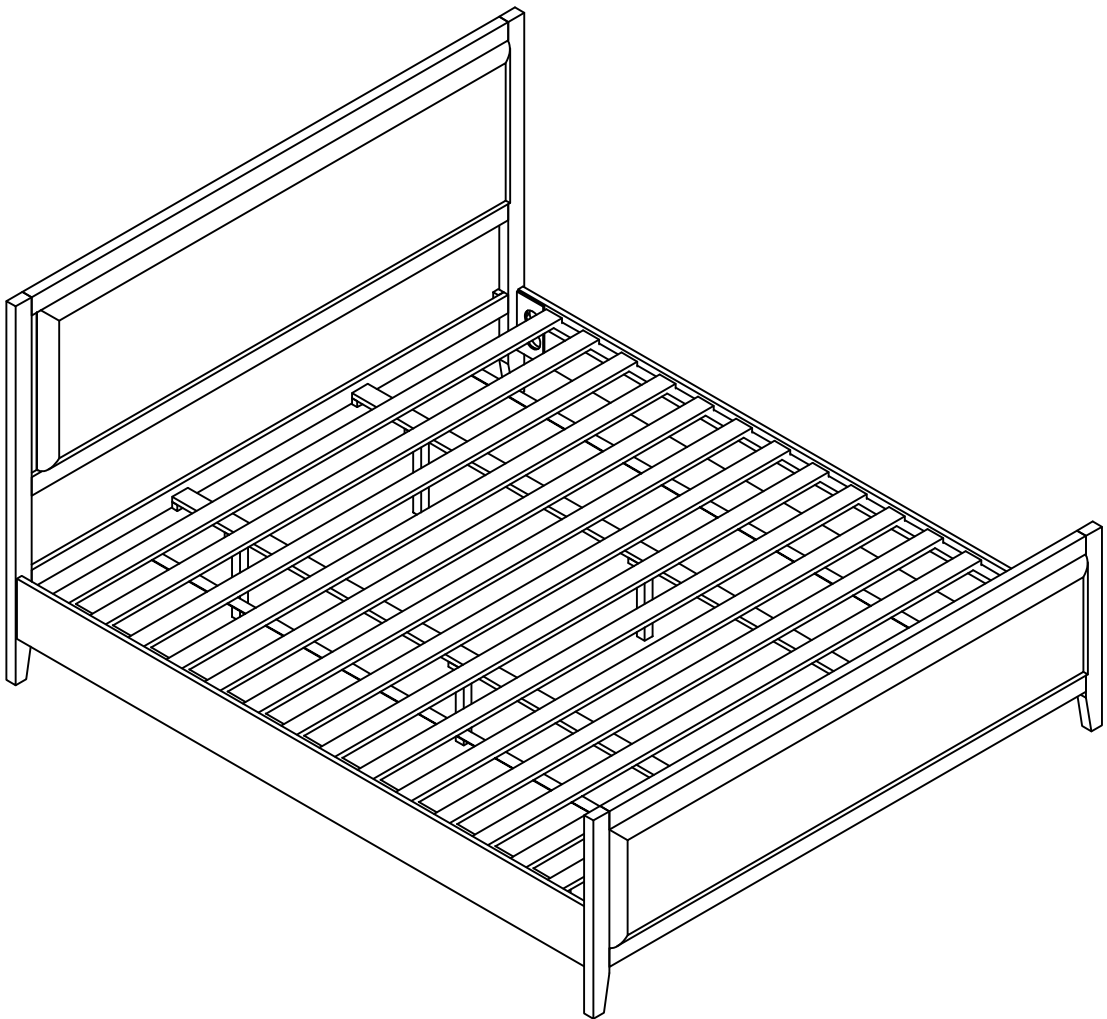



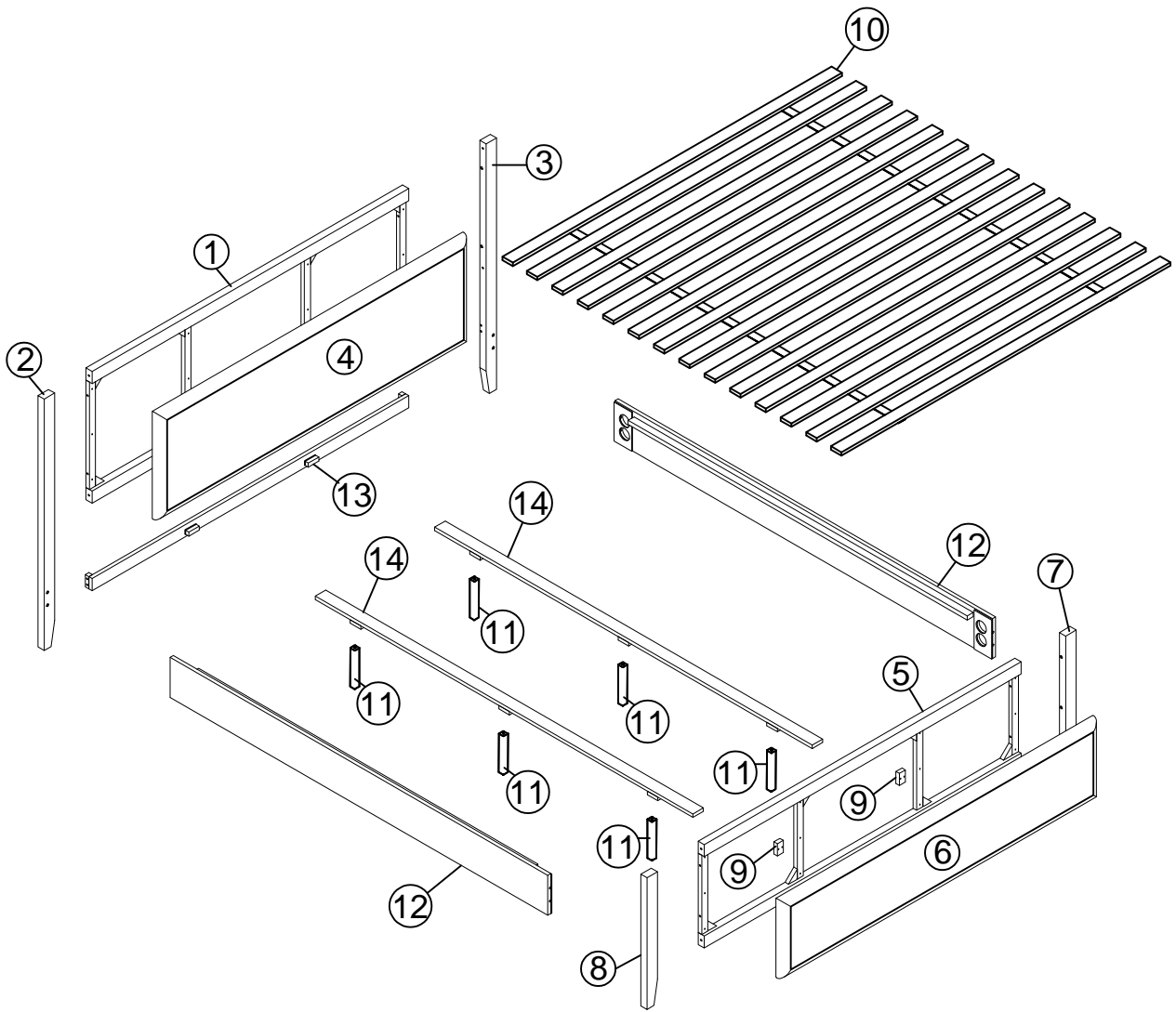

Detail View



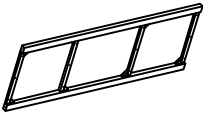
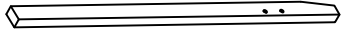
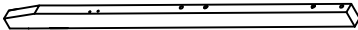

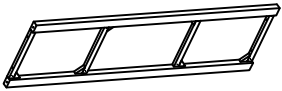
Part List

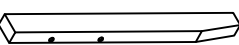
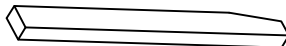
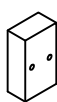
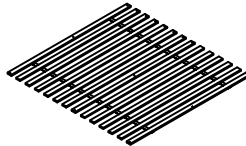
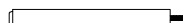









**70840.00-Q-H / 70840.00-K-H
70840.00-CK-H**

<p>① x 1 PC</p>  <p>Frame Headboard</p>	<p>② x 1 PC</p>  <p>Left Headboard Leg</p>
<p>③ x 1 PC</p>  <p>Right Headboard Leg</p>	<p>④ x 1 PC</p>  <p>Headboard Mattress</p>
<p>⑤ x 1 PC</p>  <p>Panel Footboard</p>	<p>⑥ x 1 PC</p>  <p>Footboard Mattress</p>
<p>⑦ x 1 PC</p>  <p>Right Footboard Leg</p>	<p>⑧ x 1 PC</p>  <p>Left Footboard Leg</p>
<p>⑨ x 2 PCS</p>  <p>Support Footboard</p>	<p>⑩ x 1 PC</p>  <p>Slat</p>
<p>⑪ x 6 PCS</p>  <p>Support Leg</p>	

**70840.00-Q-P / 70840.00-K-P
70840.00-CK-P + Hardware inside**

<p>⑫ x 2 PCS</p>  <p>Side Rails</p>	<p>⑬ x 1 PC</p>  <p>Support Headboard</p>
<p>⑭ x 2 PCS</p>  <p>Center support bar</p>	

Hardware List

(A) x 8PCS  Ø5/16"x60mm	(B) x 2PCS  Ø1/4"x30mm	(C) x 18PCS  Ø5/16"x13mm
Bolts	Bolts	Spring Washer
(D) x 10PCS  Ø5/16"x19mm	(E) x 10PCS  Ø10x40mm	(F) x 8PCS  Ø5/16"x90mm
Flat Washer	Wood dowel	Bolts
(G) x 8PCS  Φ5/16"	(H) x 8PCS  Φ5/16"	(I) x 34PCS  Ø4x25mm
Hexagon nuts	Curved washers	Wood screws
(K) x 1PC  100*30*4mm	(L) x 1PC  Φ5/16"	
Allen key	Wrench	

ASSEMBLY TOOLS REQUIRED (NOT INCLUDED)

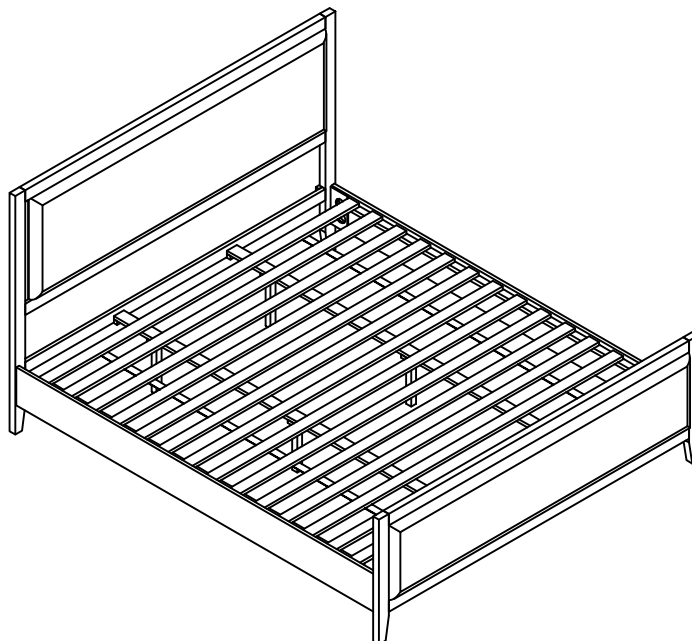
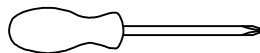

STEP: 1

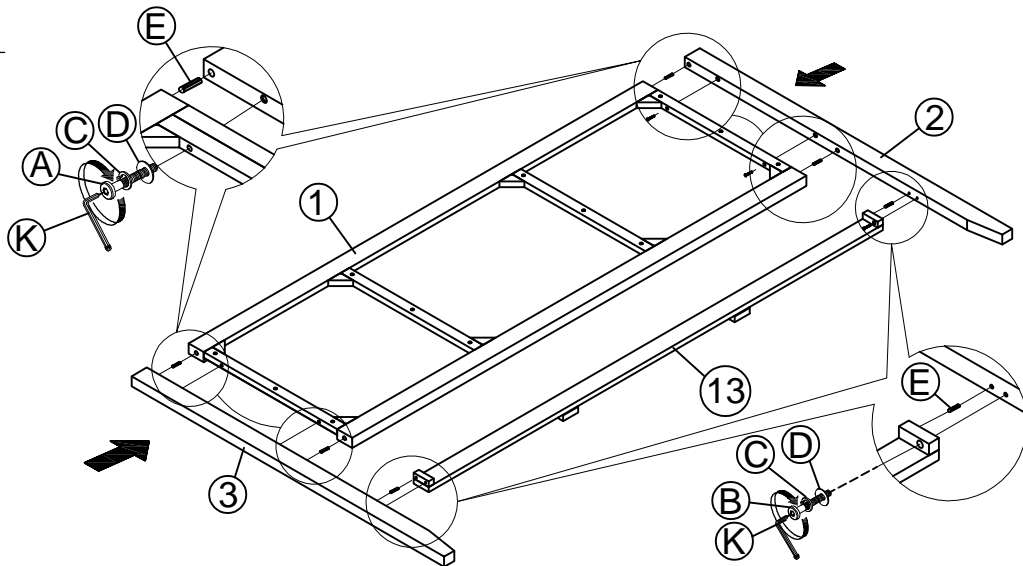

Attach the right headboard leg (3) and left headboard leg (2) to the frame headboard (1) using the bolts (A), spring washers (C), flat washers (D), and wooden dowels (E), Allen key (K) .

Attach the right headboard leg (3) and left headboard leg (2) support headboard (13) using bolts (B), spring washers (C), flat washers (D), and wooden dowels (E), Allen key (K).
Tightening the bolts completely at this step

STEP: 2

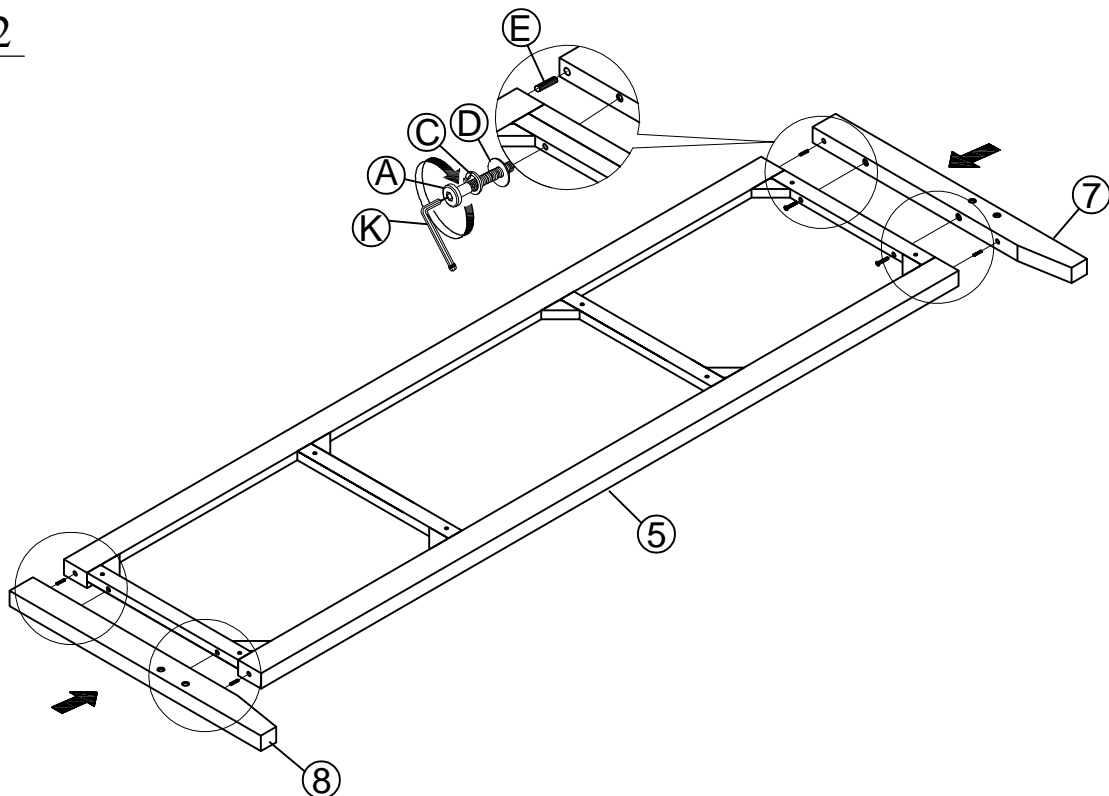

Attach the right footboard leg (7) and left footboard leg (8) to the frame headboard (5) using the bolts (A), spring washers (C), flat washers (D), and wooden dowels (E), Allen key (K) .Tightening the bolts completely at this step

STEP: 3

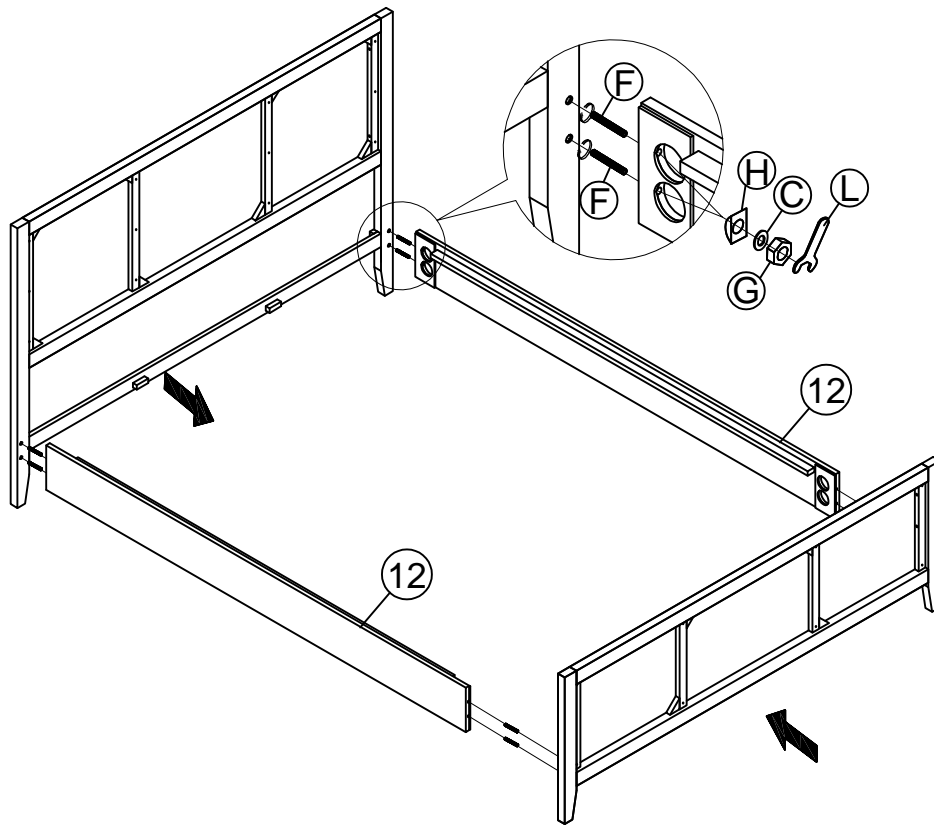

Assemble the siderails (12), to the headboard in step (1), and the footboard in step (2), using bolts (F), curved washers (H), Spring washer (C), Hexagon nuts (G), and Wrench (L). Tighten all nuts in this step.

STEP: 4

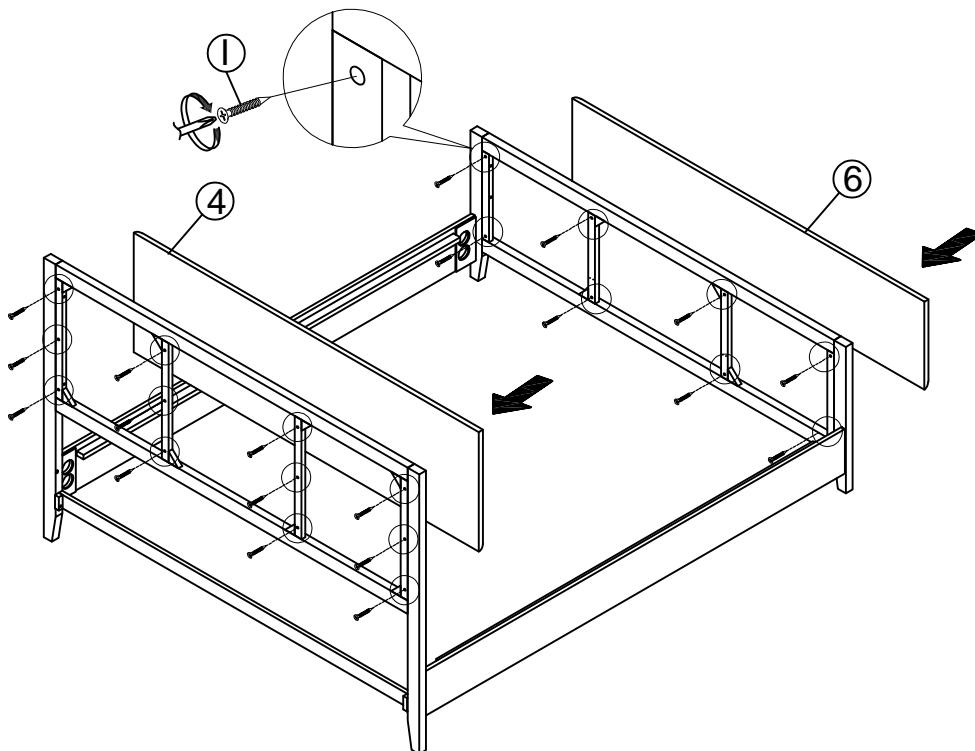

Assemble the headboard mattress (4) into the headboard step (1), assemble the footboard mattress (6), into the footboard step (2), Wood screws (I). Note: do not tighten too hard.

STEP: 5

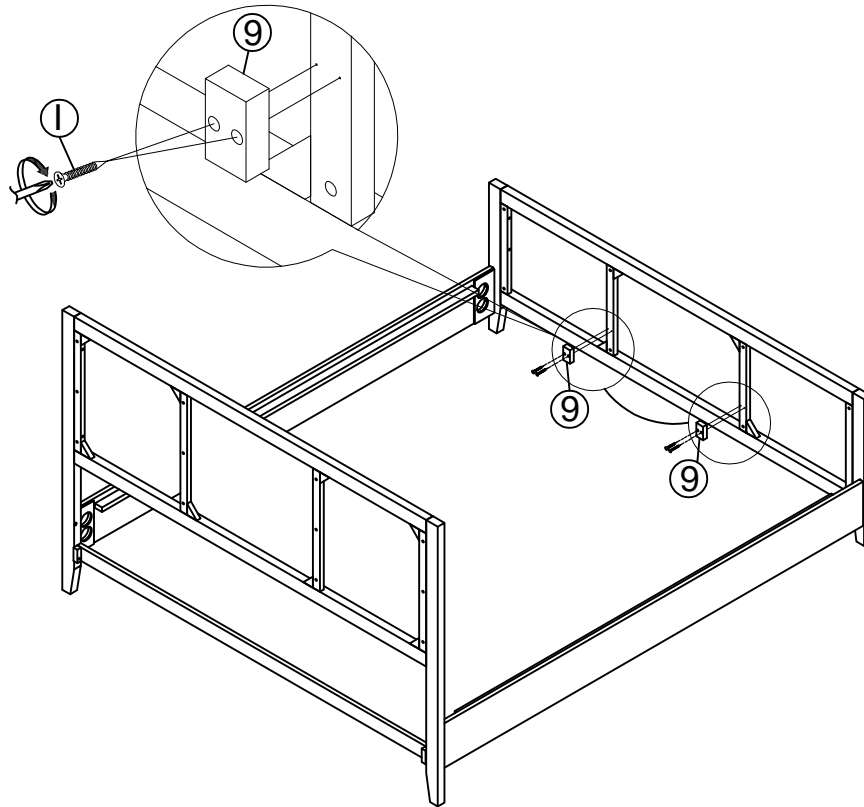

Assemble the support footboard (9) onto the inside of the footboard, using Wood screws (I). Be careful not to tighten too hard.

STEP: 6

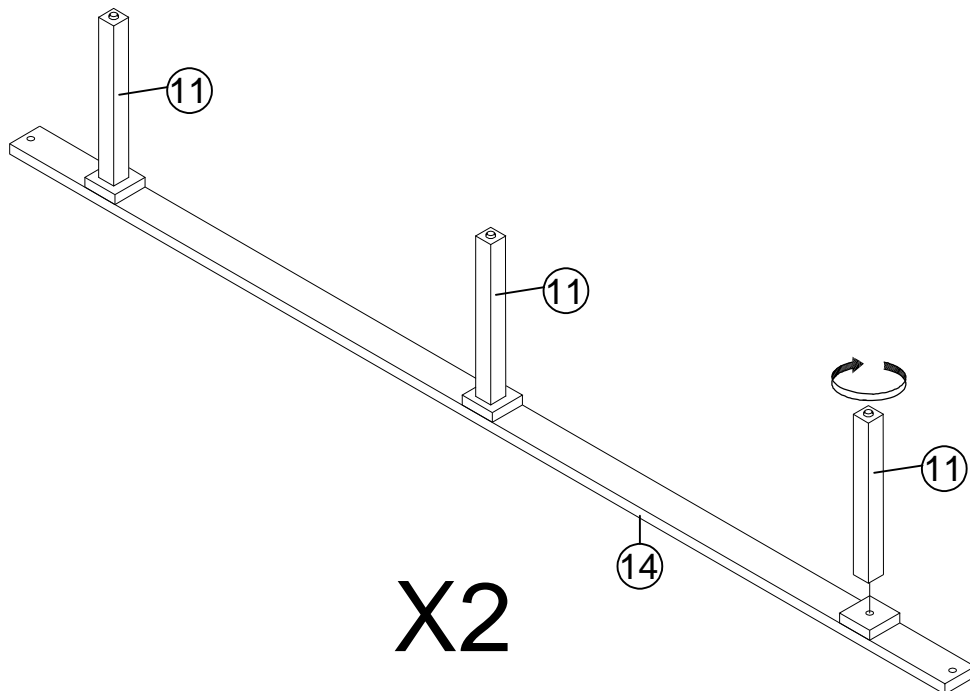

Assemble the support leg (11) into the Center support bar (14)

STEP: 7

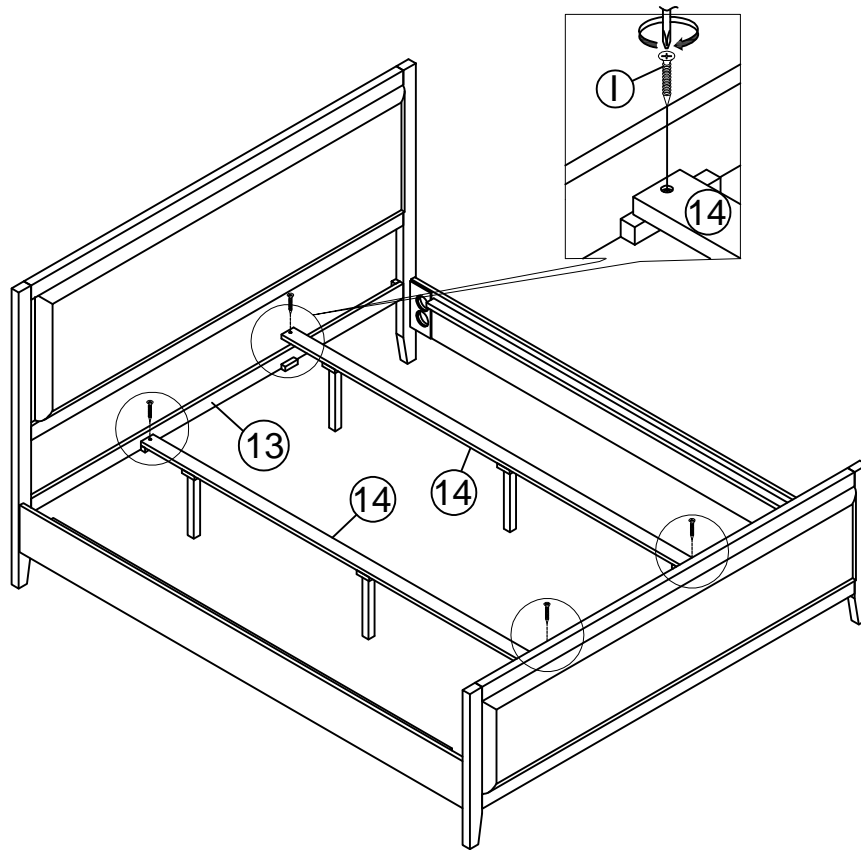

Assemble Center support bar (14) in step (6) to the support headboard (13) in step (1) and support footboard (9), in step (5), Wood screws (I). Be careful not to overtighten.

STEP: 8

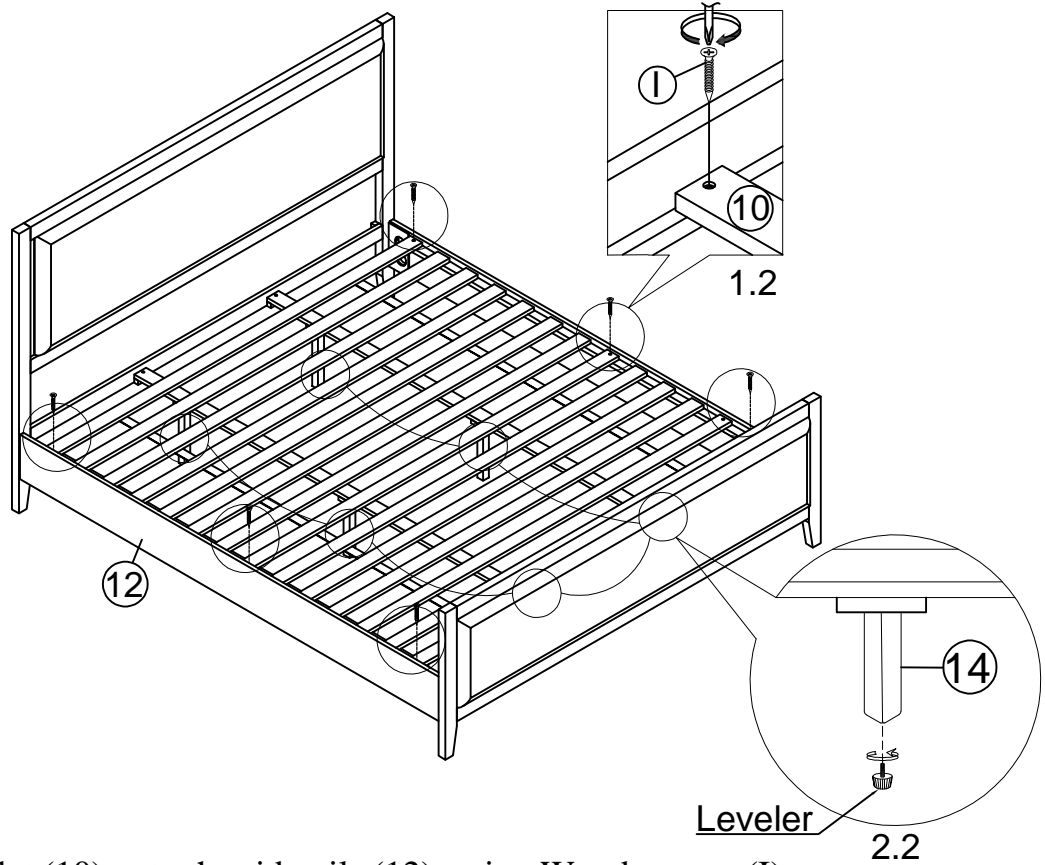

1.2 Assemble the slat (10) onto the siderails (12), using Wood screws (I).
Be careful not to tighten too hard
2.2 Adjust the leveler high and low to balance

FINAL

