

# **CROSLEY**

---

## FURNITURE

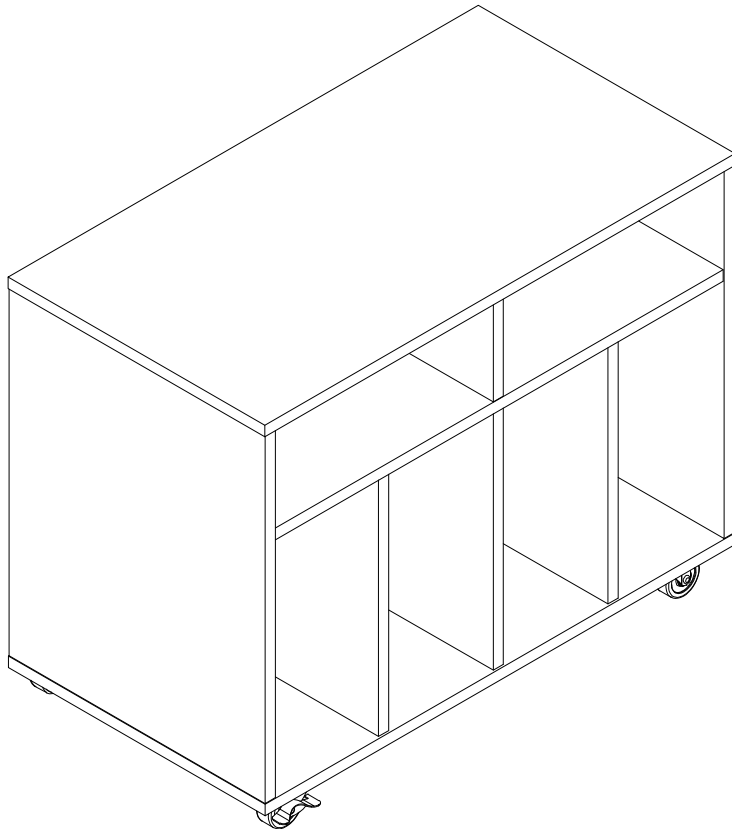





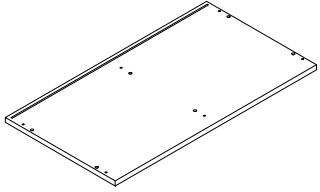
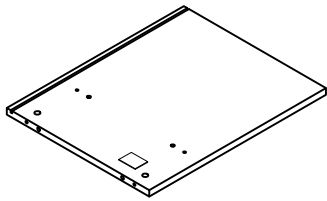
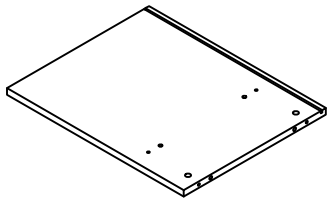
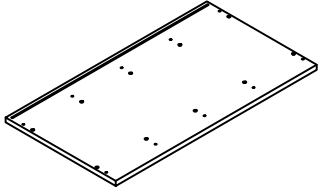
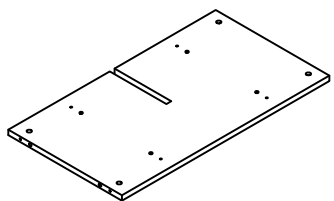
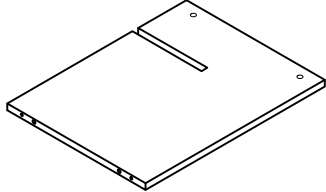
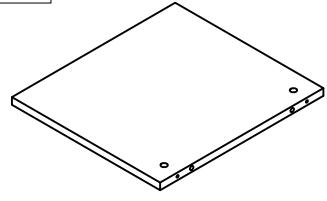
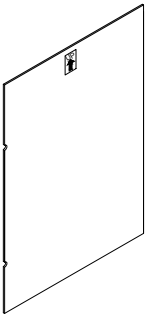
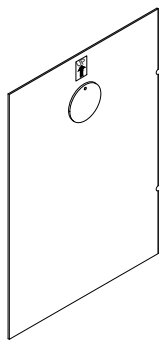



### Rolling Record Storage Console CF1134



# PART LIST

<p><b>A</b></p> 	<p><b>B</b></p> 	<p><b>C</b></p> 	<p><b>D</b></p> 	<p><b>E</b></p> 
<p>Top Panel 1 PC</p>	<p>Left Panel 1 PC</p>	<p>Right Panel 1 PC</p>	<p>Bottom Panel 1 PC</p>	<p>Fixed Shelf Panel 1 PC</p>
<p><b>F</b></p> 	<p><b>G</b></p> 	<p><b>H</b></p> 	<p><b>I</b></p> 	
<p>Center Partition Panel 1 PC</p>	<p>Side Partition Panel 2 PCS</p>	<p>Left Back Panel 1 PC</p>	<p>Right Back Panel 1 PC</p>	

# HARDWARE LIST

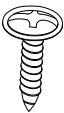
<p><b>#1</b></p>  <p>Ø6*35mm</p>	<p><b>#2</b></p>  <p>Ø15*9mm</p>	<p><b>#3</b></p>  <p>Ø20mm</p>	<p><b>#4</b></p>  <p>Ø8*30mm</p>	<p><b>#5</b></p>  <p>Ø5*40mm</p>
<p>Cam Bolt 14 PCS (Extra 2)</p>	<p>Cam Lock 14 PCS (Extra 2)</p>	<p>Cam Sticker 14 PCS (Extra 1)</p>	<p>Wood Dowel 24 PCS (Extra 4)</p>	<p>Tapping Screw 10 PCS (Extra 2)</p>
<p><b>#6</b></p>  <p>14*14mm</p>	<p><b>#7</b></p>  <p>Ø3.0*16mm</p>	<p><b>#8</b></p>  <p>2"</p>	<p><b>#9</b></p>  <p>2"</p>	<p><b>#10</b></p>  <p>Ø4.5*12mm</p>
<p>Back Bracket 8 PCS (Extra 1)</p>	<p>Long Screw 8 PCS (Extra 1)</p>	<p>Locking Caster 2 PCS</p>	<p>Caster 2 PCS</p>	<p>Short Screw 16 PCS (Extra 2)</p>
<p><b>#11</b></p>  <p>Ø3.5*15mm Medium Screw 2 PCS (Extra 1)</p>				

## ADDITIONAL TOOLS (Not Provided)

Note: It is not recommended to use power tools during assembly.

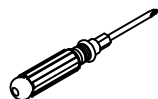

Phillips Head Screwdriver

Note: Wood dowels are intended for alignment. Additional clearance between wood dowel and pre-drilled hole is intentional for ease of assembly.

Step 1. Screw cam bolts (part #1) into panels (parts A & E) using phillips head screwdriver.

Note: Do not overtighten cam bolts. Stop tightening once threads on cam bolt are no longer visible.

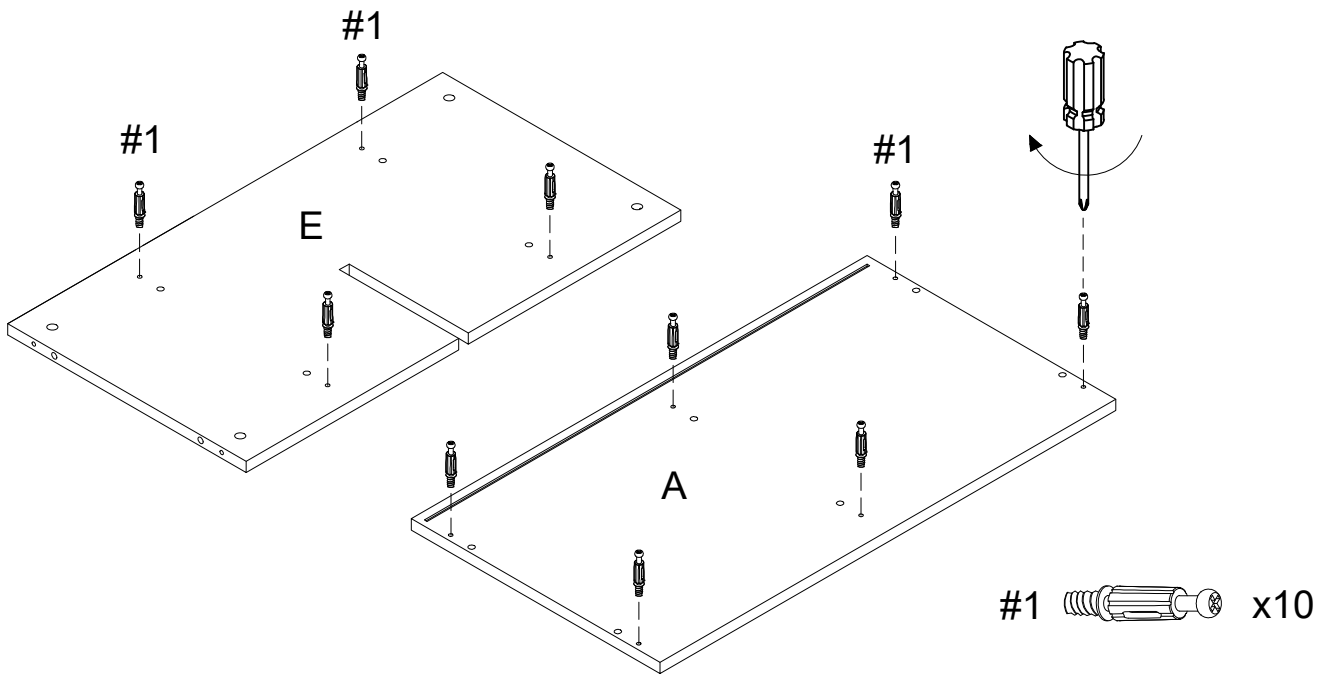

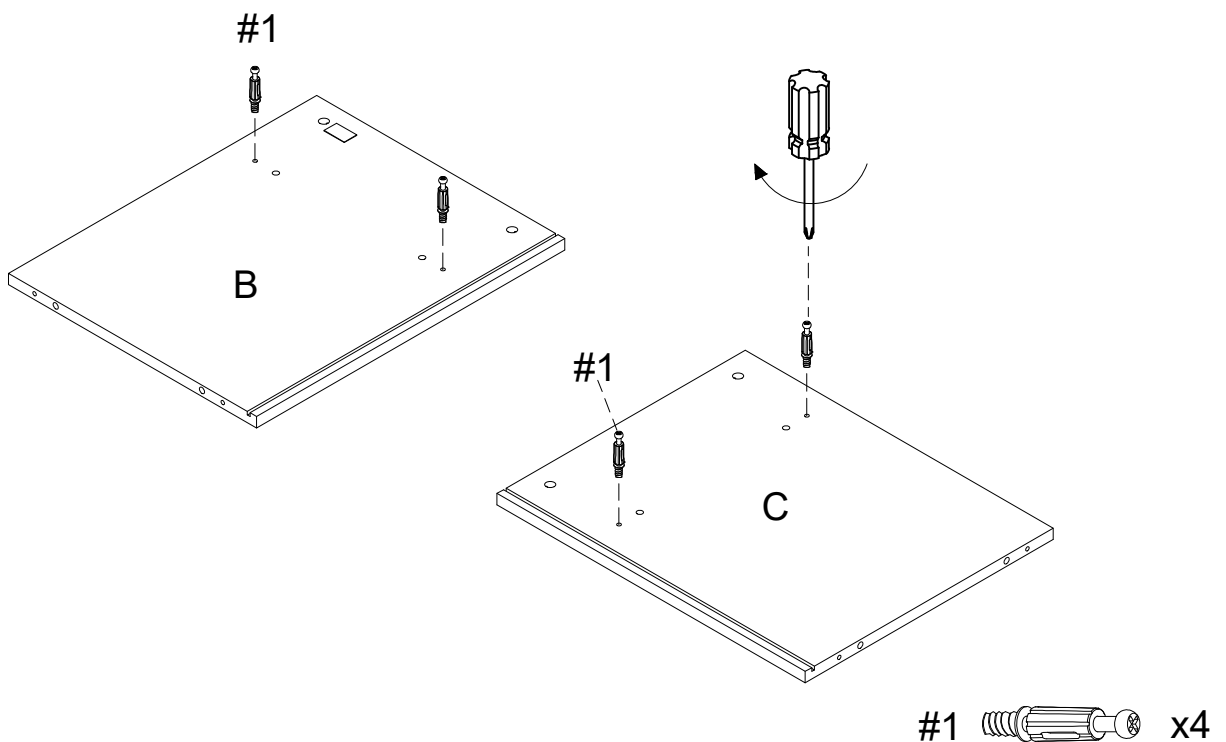

Step 2. Screw cam bolts (part #1) into panels (parts B & C) using phillips head screwdriver.

Note: Do not overtighten cam bolts. Stop tightening once threads on cam bolt are no longer visible.

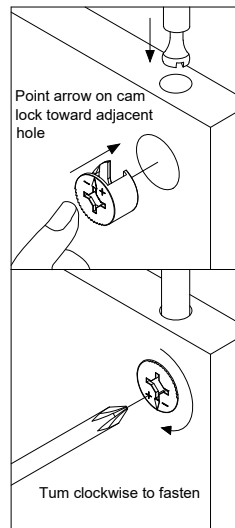
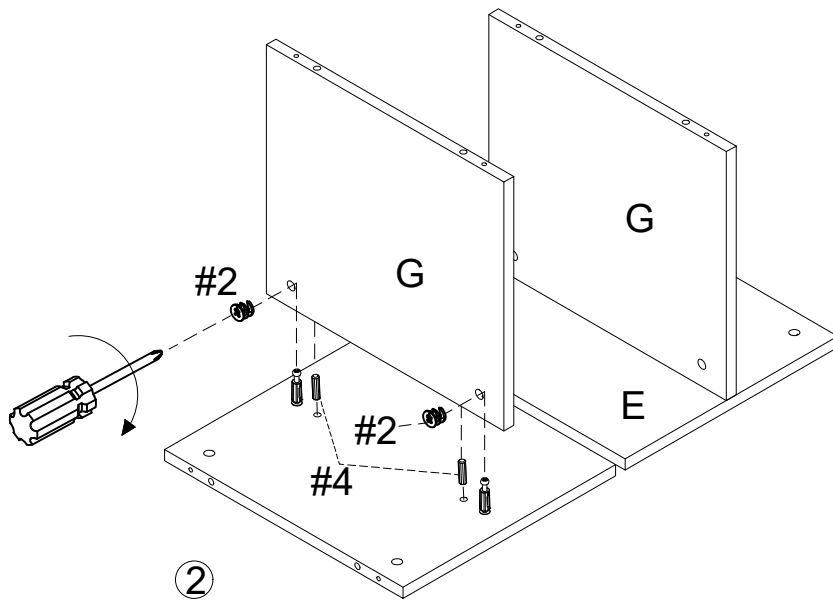
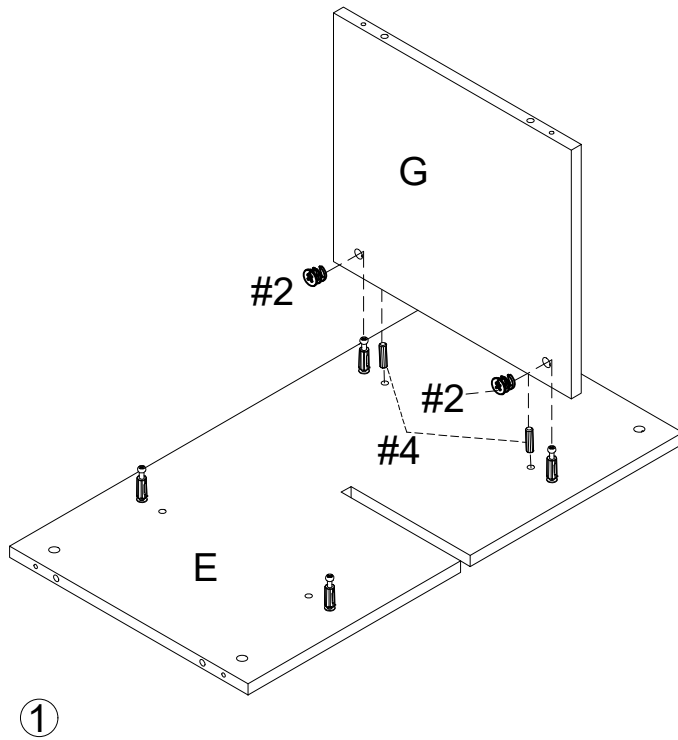

Step 3. Attach side partition panels (part G) to fixed shelf panel (part E) using wood dowels (part #4), cam locks (part #2) and phillips head screwdriver.  
Note: Cam locks must rotate a full 180°. See pictured insert.



- #2  x4
- #4  x4

Step 4. Insert center partition panel (part F) to fixed shelf panel (part E ).

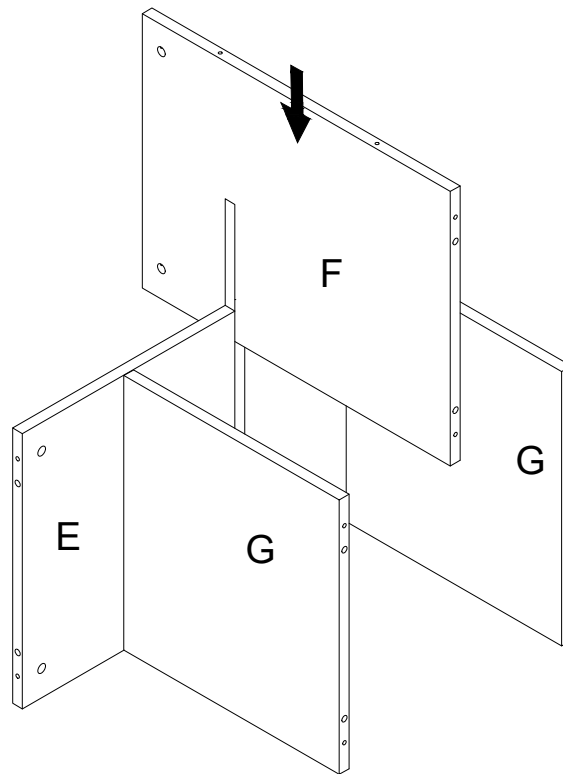

Step 5. Attach left panel (part B) to fixed shelf panel (part E) using wood dowels (part #4), cam locks (part #2) and phillips head screwdriver.  
Note: Cam locks must rotate a full 180°. See pictured insert.

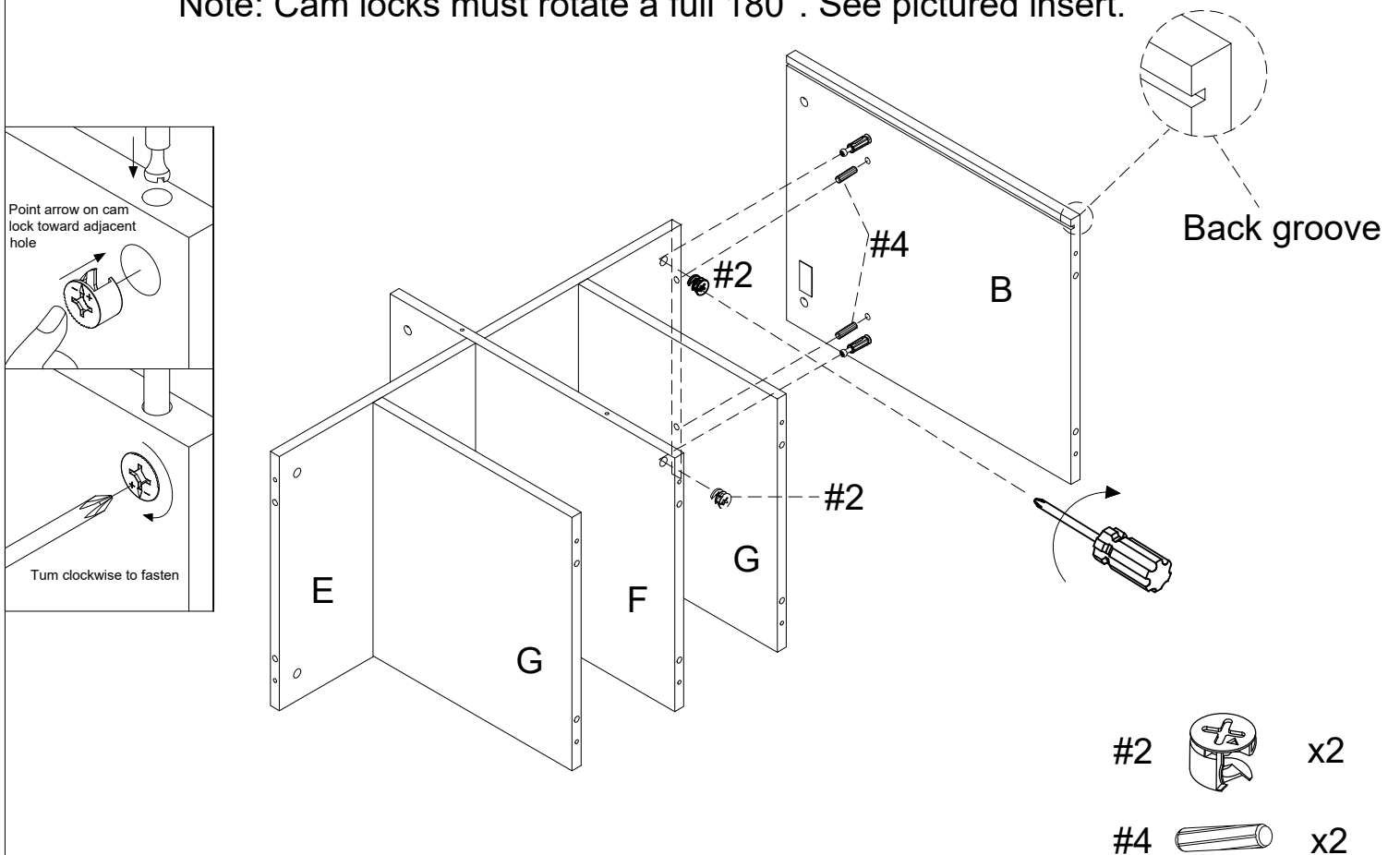

Step 6. Attach right panel (part C) to fixed shelf panel (part E) using wood dowels (part #4), cam locks (part #2) and phillips head screwdriver.  
 Note: Cam locks must rotate a full 180°. See pictured insert.

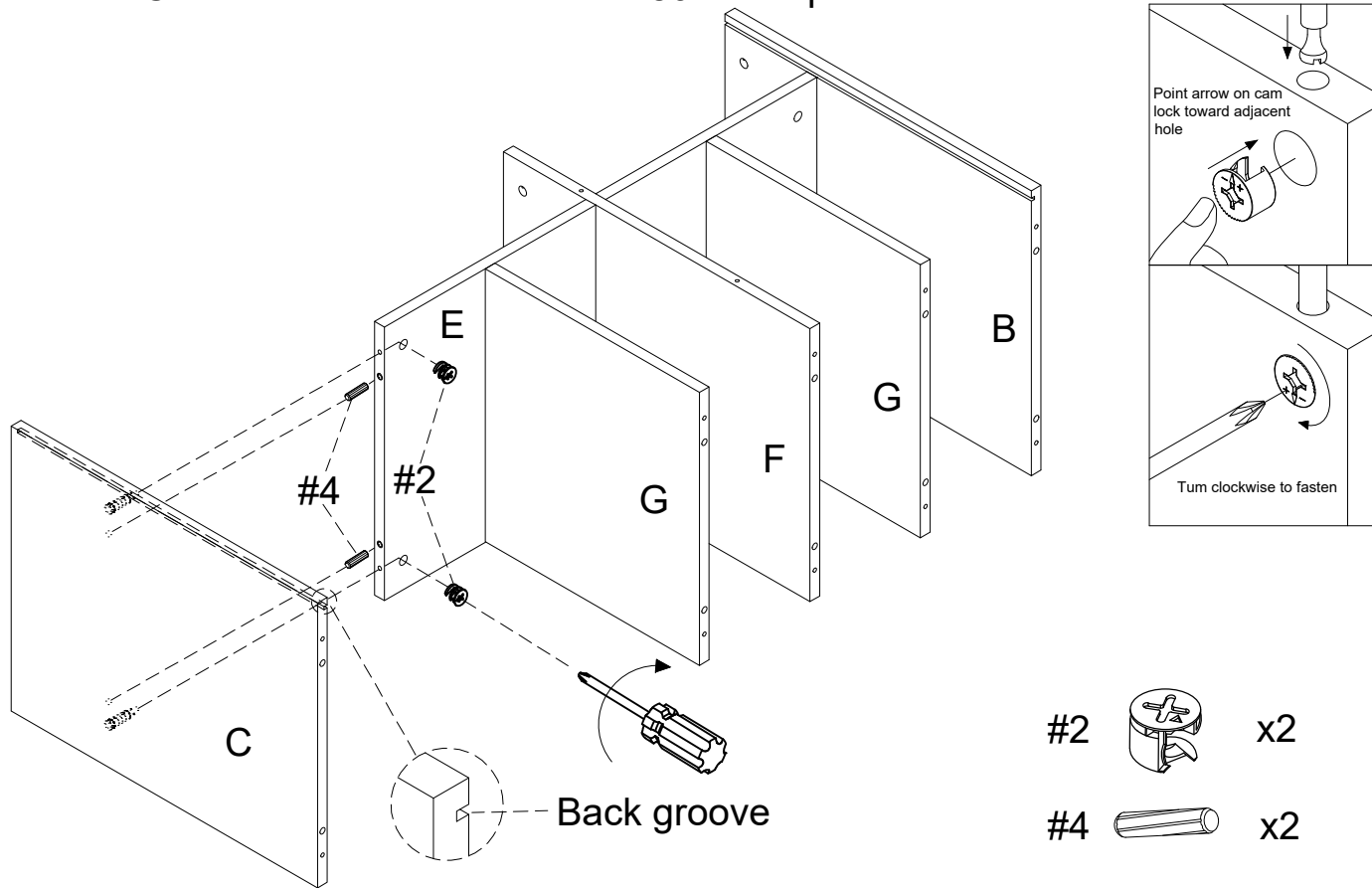

Step 7. Attach bottom panel (part D) to assembled unit (parts B, C, F & G) using wood dowels (part #4), tapping screws (part #5) and phillips head screwdriver.

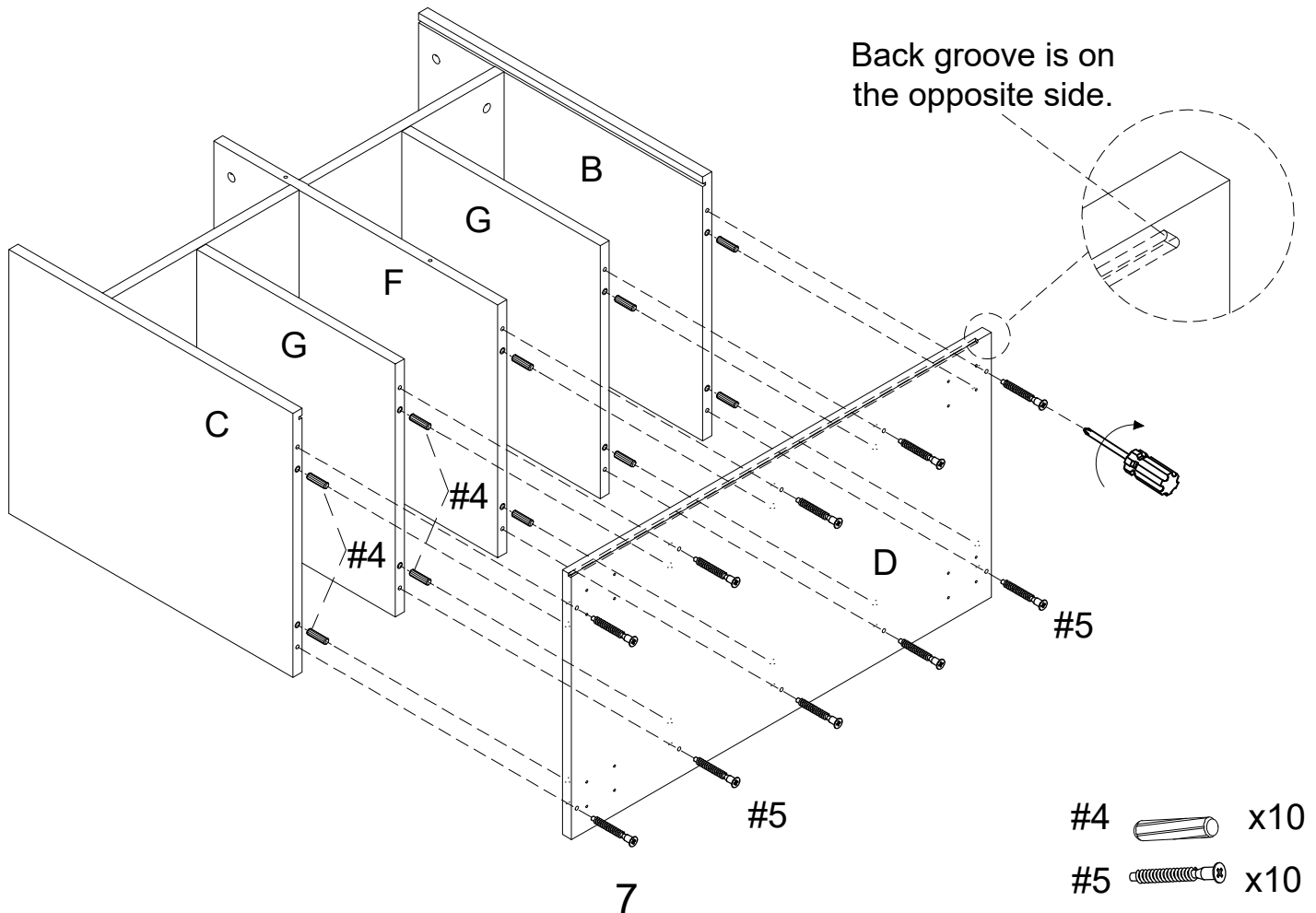

Step 8. Attach locking casters (part #8) and casters (part #9) to bottom panel (part D) using short screws (part #10) and phillips head screwdriver.

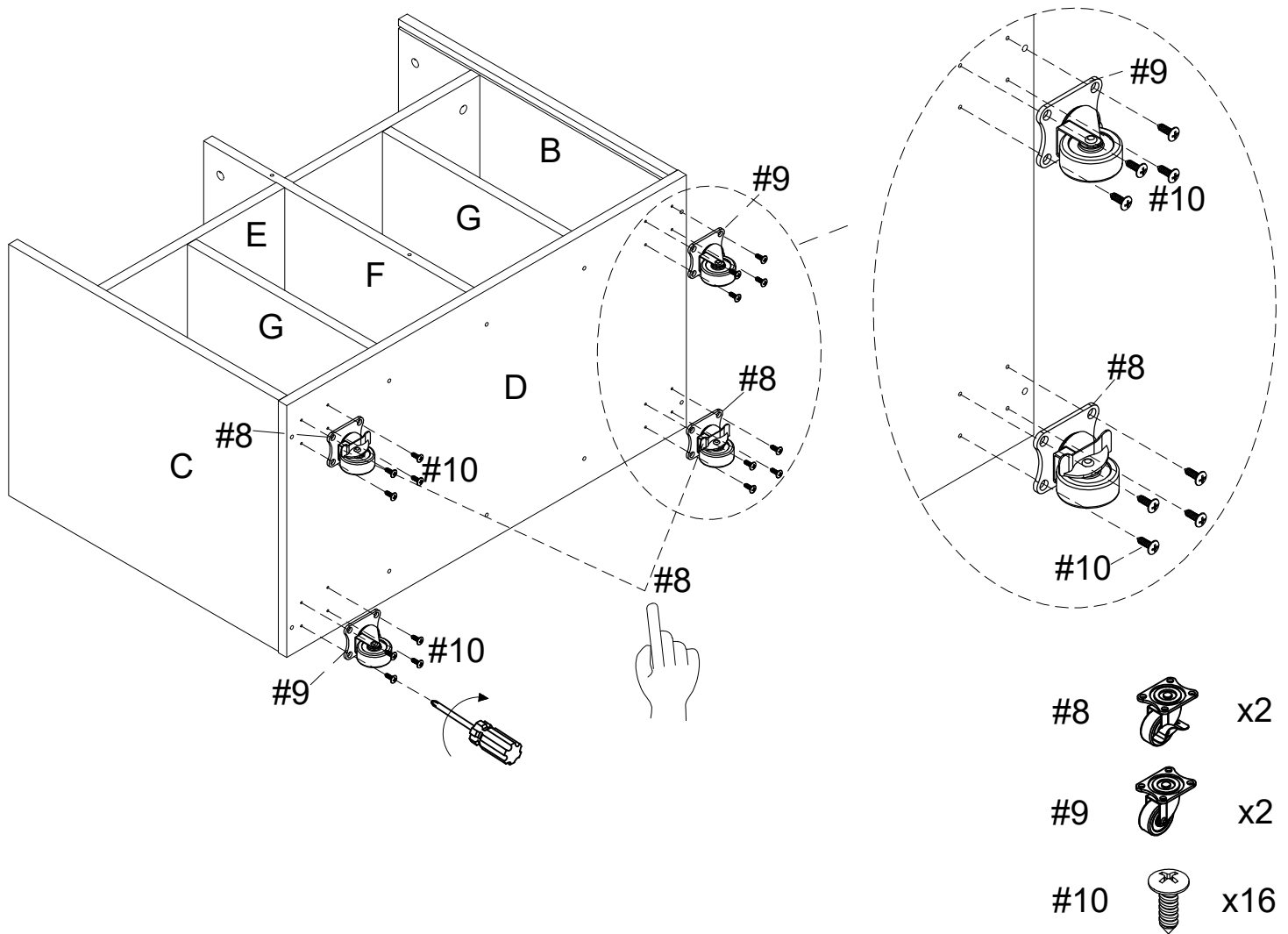

Step 9. Carefully turn assembled unit upright. Insert back panels (parts H & I) into grooves of assembled unit (parts B, C & D).

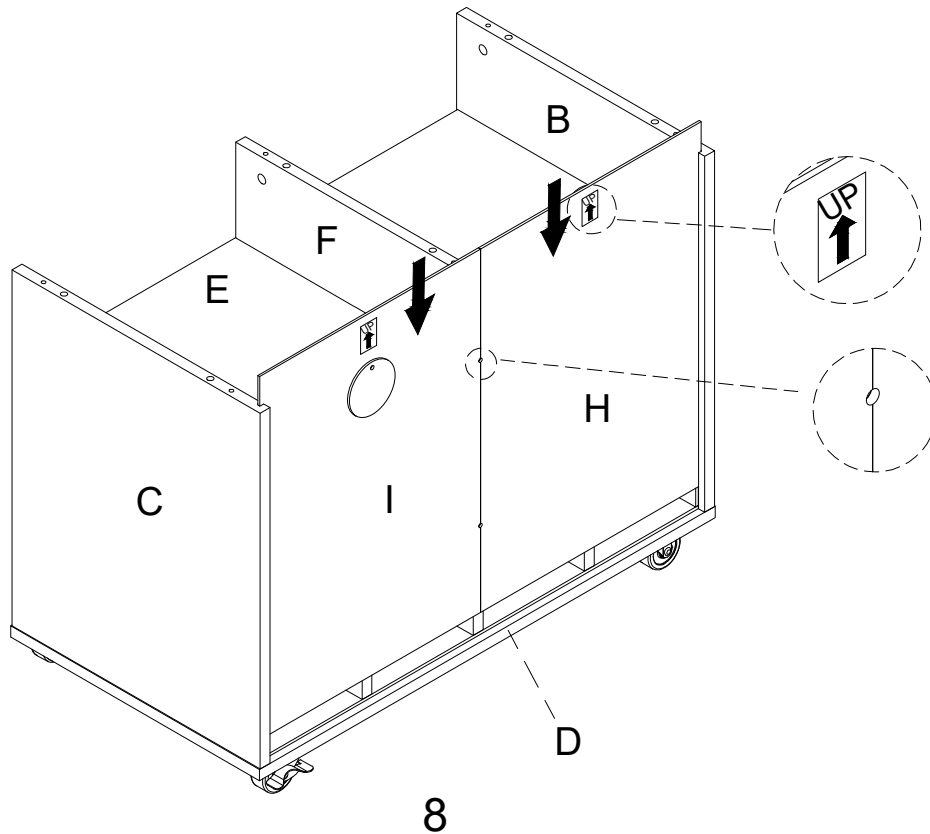



Step 10. Attach top panel (part A) to assembled unit (parts B, C, F, H & I) using wood dowels (part #4), cam locks (part #2) and phillips head screwdriver.  
 Note: Cam locks must rotate a full 180°. See pictured insert.

Back groove is on the opposite side.

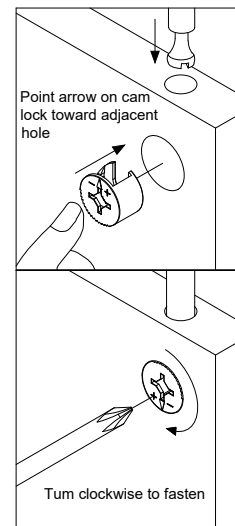
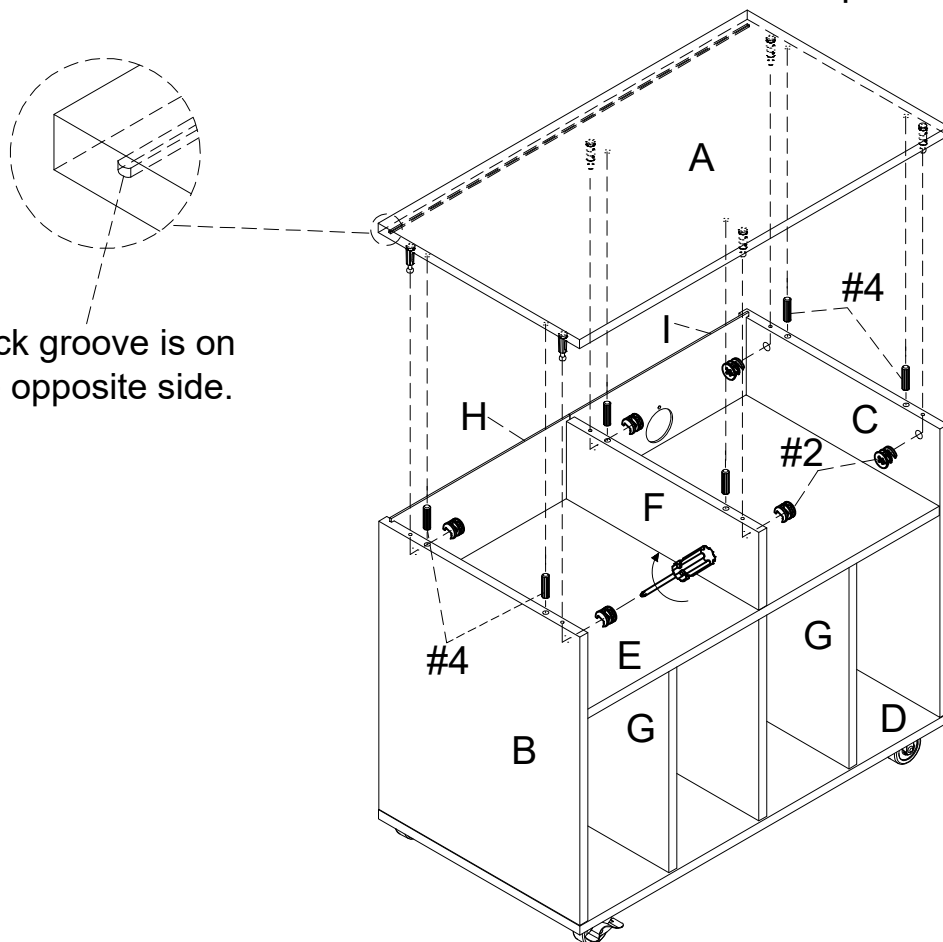

#2  x6

#4  x6

Step 11. Secure back brackets (part #6) at the corner of back panels (parts H & I) using long screws (part #7) and phillips head screwdriver.  
 Secure back panels (parts H & I) using medium screws (part #11) and phillips head screwdriver.

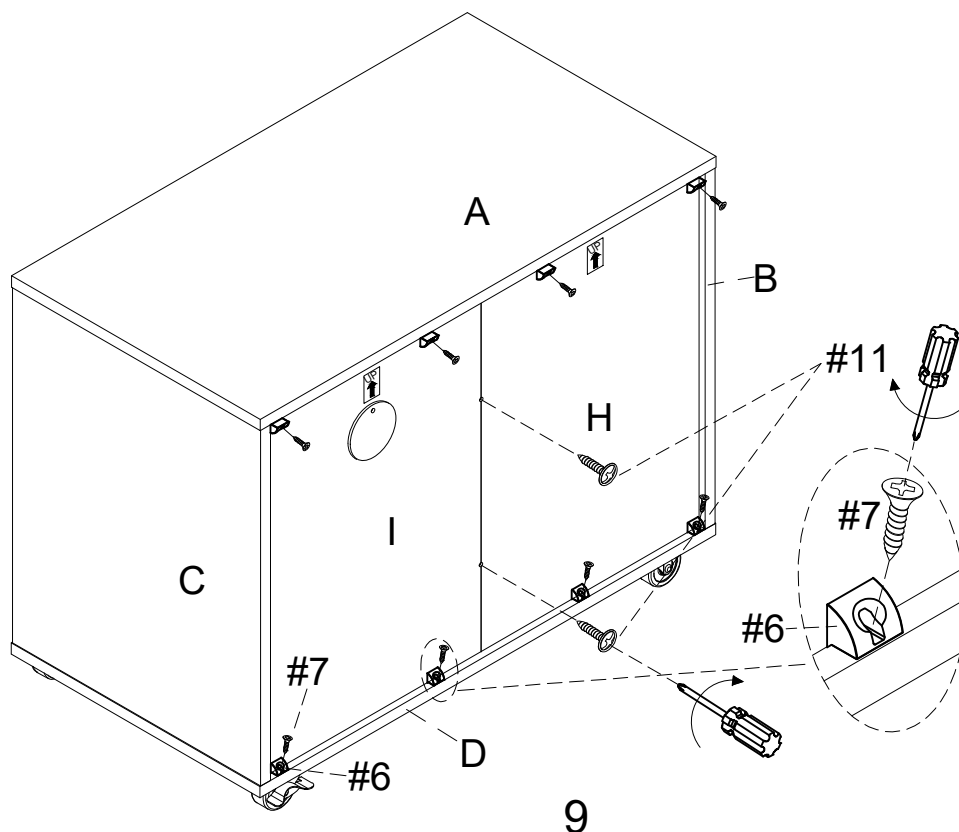

#6  x8

#7  x8

#11  x2

Step 12. Using cam stickers (part #3) cover all cam locks (part #2).

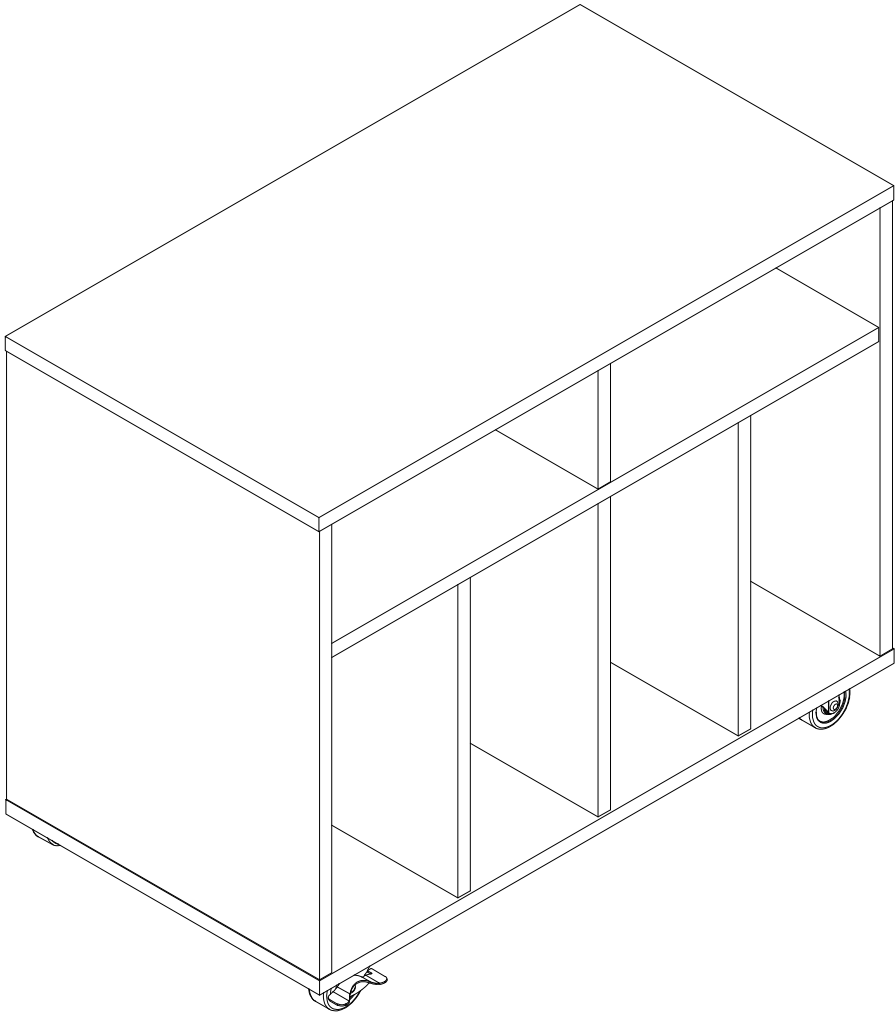
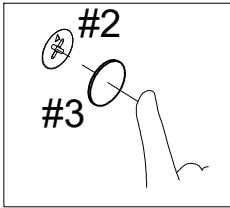

#3  x14