























# Assembly Instructions

## Care & Maintenance

 	<ul style="list-style-type: none"><li>● Not for commercial use. For residential use only.</li></ul>
 	<ul style="list-style-type: none"><li>● Furniture may scratch floors. We recommend using furniture pads to protect your floors.</li></ul>
 	<ul style="list-style-type: none"><li>● Do not put hot items directly on furniture surface.</li></ul>
 	<ul style="list-style-type: none"><li>● Do not clean furniture with harsh cleansers or polish.</li></ul>
 	<ul style="list-style-type: none"><li>● Do not place furniture under direct sunlight.</li></ul>
 	<ul style="list-style-type: none"><li>● Do not place furniture near heating or cooling vents.</li></ul>
 	<ul style="list-style-type: none"><li>● Do not write on furniture without a padded barrier to protect the surface.</li></ul>
 	<ul style="list-style-type: none"><li>● Do not place furniture outside. For indoor use only.</li></ul>
 	<ul style="list-style-type: none"><li>● Stains may be removed with mild soap solution and damp cloth.</li></ul>
 	<ul style="list-style-type: none"><li>● Children should not climb or jump on the furniture.</li></ul>
 	<ul style="list-style-type: none"><li>● Dust and pick-up spills using a clean, non-colored, lint-free cloth.</li></ul>

Please look in the box for hardware packs and legs.

Sets often ship in multiple boxes and may arrive a day or two apart.

Queen Bed  
N757P283653W/N757P283654W



Part List



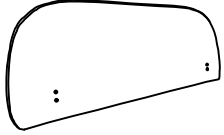
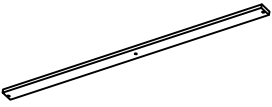
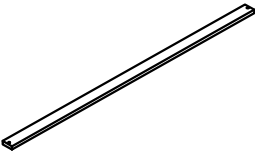





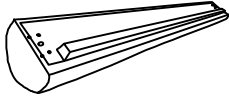
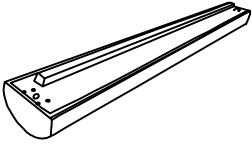
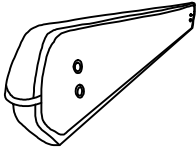
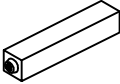
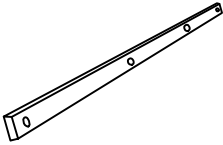
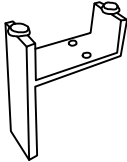

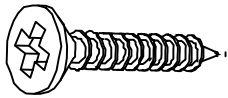
N757P283653W

Label	Picture	Description	QTY
④		Headboard	1
⑤		Slats	4
⑥		Slats	6

Part List

N757P283654W

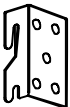
Label	Picture	Description	QTY
①		Side flank(R)	1
②		Side Panel(L)	1
③		Footboard	1
⑦		Center Support bar fitting	4
⑧		Center Support bar	1
⑨		Bed leg	2

Hardware		N757P283653W	
Label	Picture	Description	QTY
(A)		Screw(4x30mm)	36+1
(B)		Bolts(1/4x30mm)	4+1
(C)		Bolts(5/16x40mm)	12+1
(D)		Bolts(1/4x60mm)	4+1
(E)		Spring washer(5/16x20mm)	12+1
(F)		Flat washer(5/16x20mm)	12+1
(G)		Spring washer(1/4x18mm)	8+1
(H)		Flat washer(1/4x18mm)	8+1
(T)		Hinge(L)	2
(K)		Hinge(R)	2
(M)		Allen wrench(M4)	1+1

# Assembly Preparation

Before Beginning assembly:

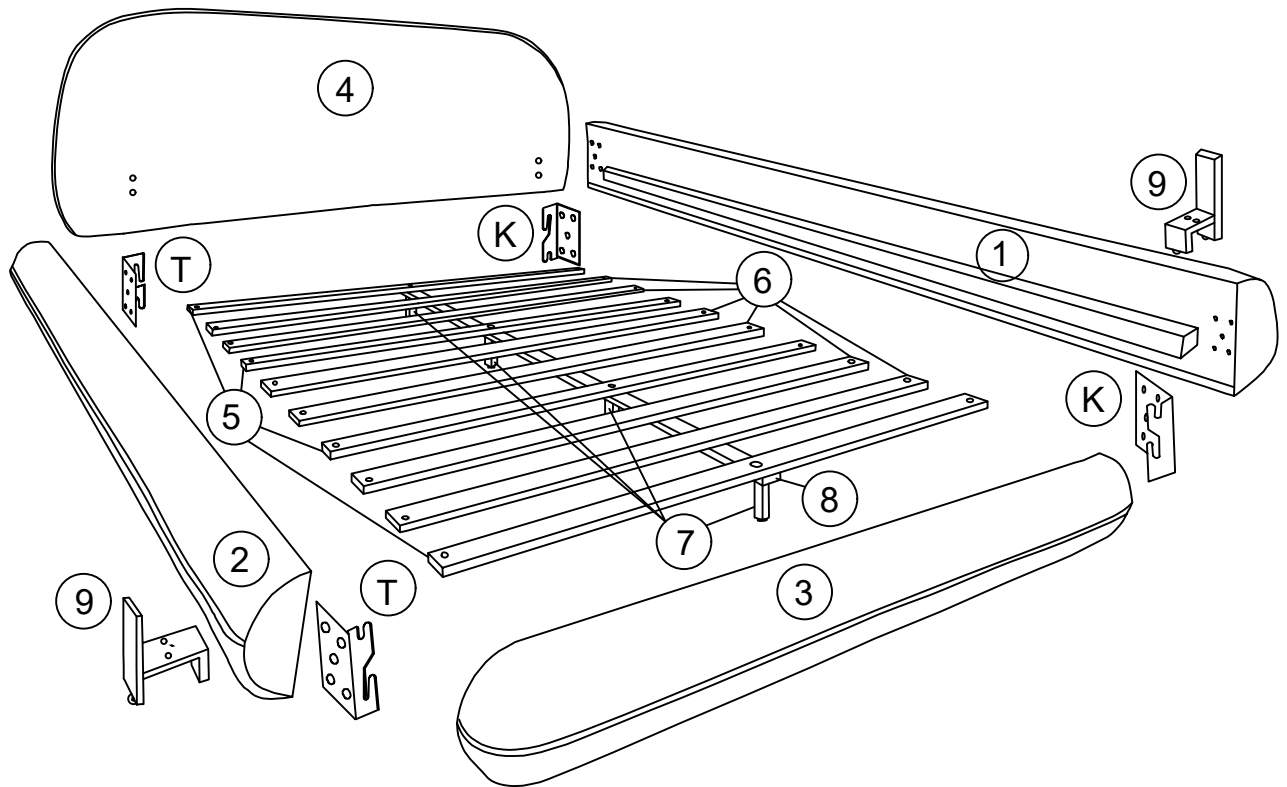

A		x36pcs+1	F		x12pcs+1
B		x 4pcs+1	G		x8pcs+1
C		x12pcs+1	H		x8pcs+1
D		x4pcs+1	M		x1pcs+1
E		x12pcs+1			

- Read instructions, cover to cover
- Have 2 adults on hand for assembly
- Do not assemble on flooring or carpet
- Assemble on a clean non-marring surface (packing foam)
- Save all packaging until finished

## Assembly Steps

### OVERVIEW

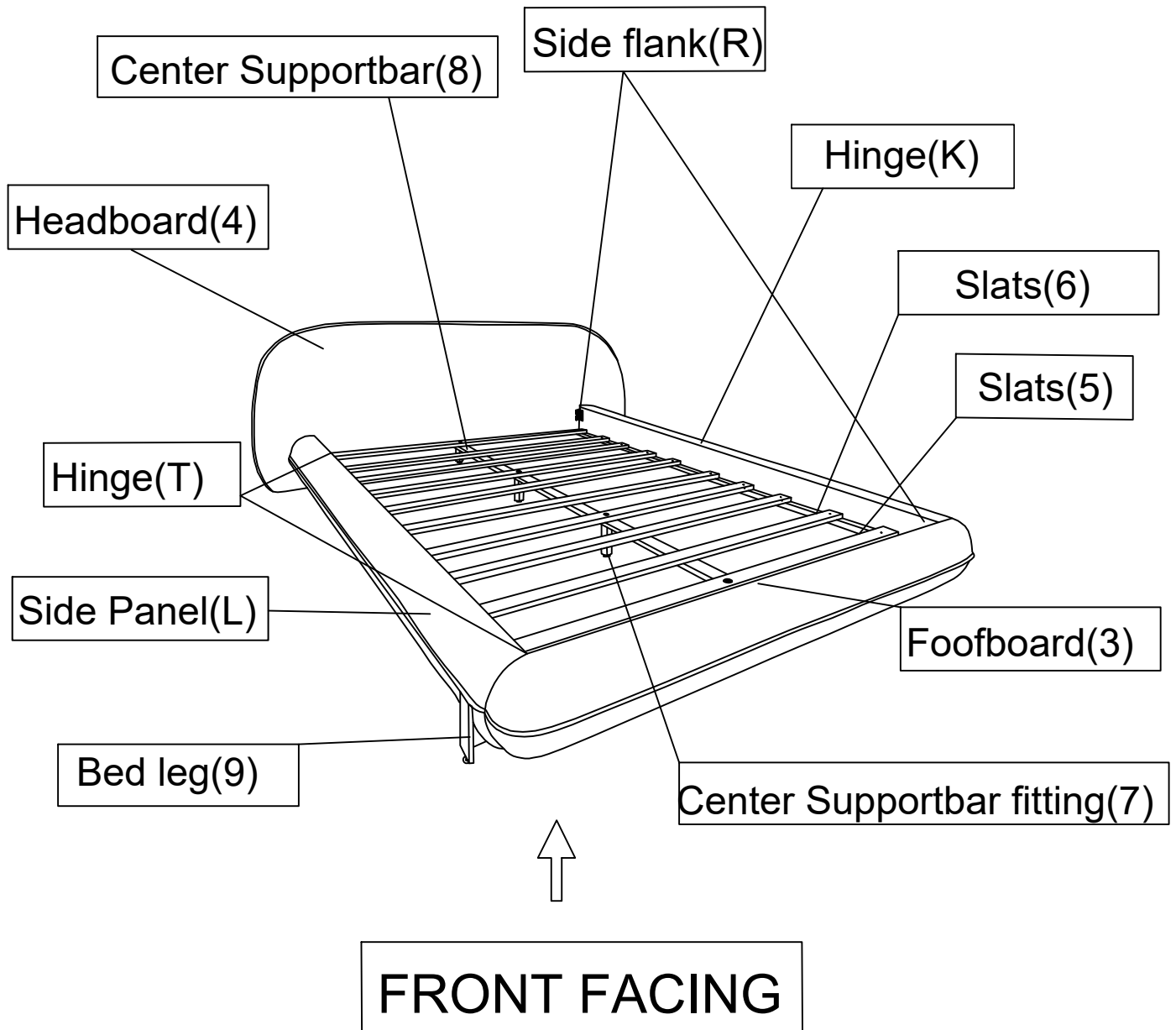

This Bed have multiple parts and may require up to 30 minutes to assemble. To give you an overview of the Bed parts, the above picture is to help you put the various parts into perspective. Please read through the instructions below to familiarise yourself with the parts and steps before assembly.

Note: It is recommended that you have an adult partner to assist during the entire assembly process.

# 6 W H S

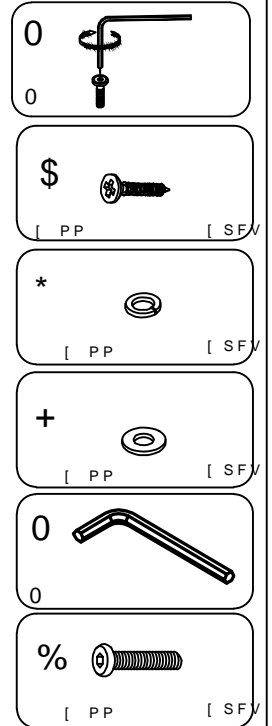
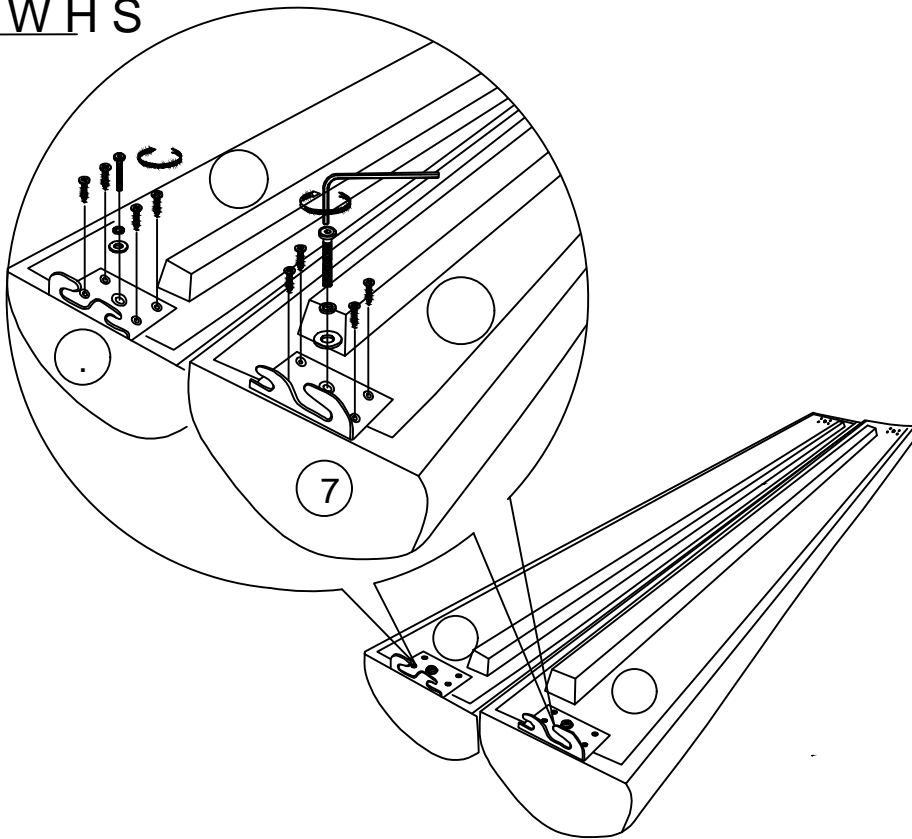

Step 1: Attach the Hinge (R) (K) to the Side Panel (R) (1), attach the Hinge (L) (T) to the Side Panel (L) (2). By using the Bolts (B) and Flat Washer (H) with the Spring Washer (G) and Screw (A) to connect the Hinge and the Side Panel (Note: The hinge hook is facing down)

# 6 W H S

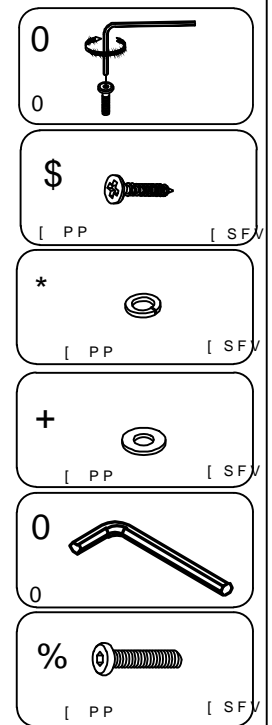
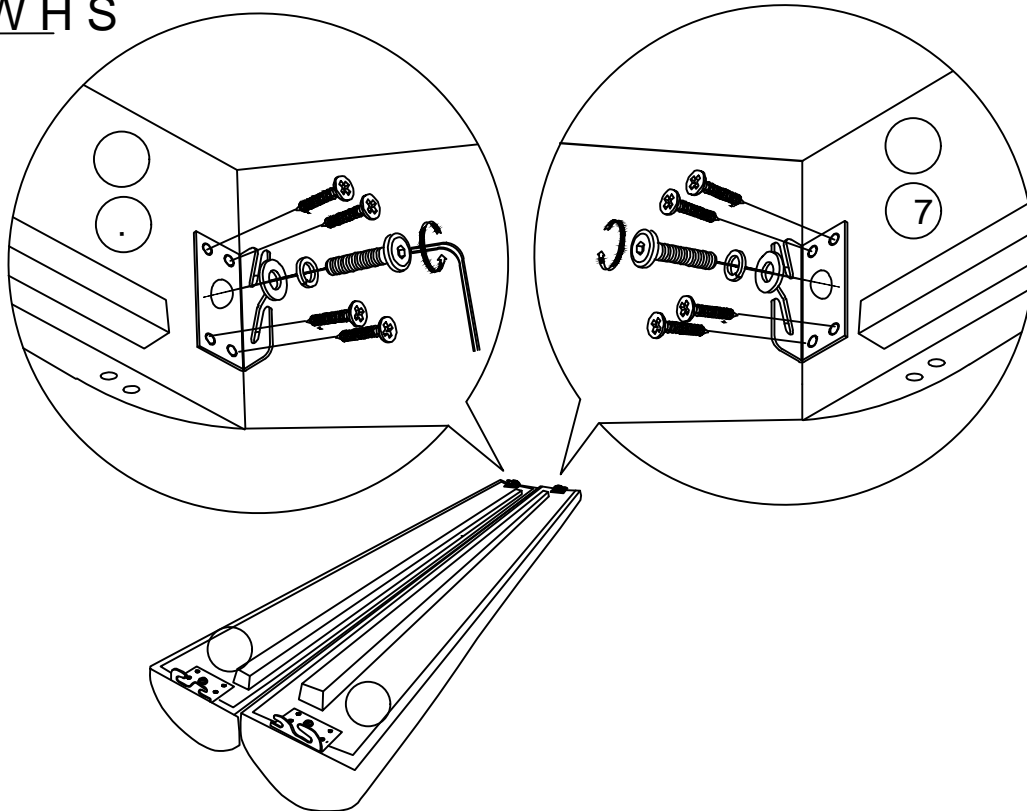

Step 2: Use the Screw (A) and the Bolts (B) with M4 Allen Wrench (M) to connect the Hinge and the Side Panel (Note :The direction of the Hinge)

# 6 W H S

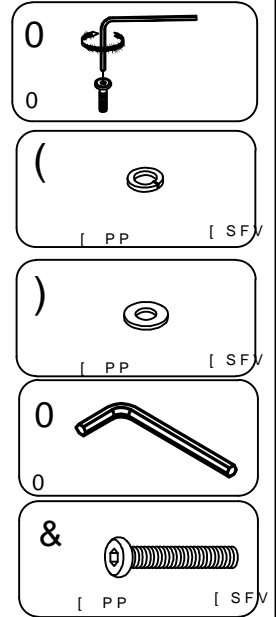
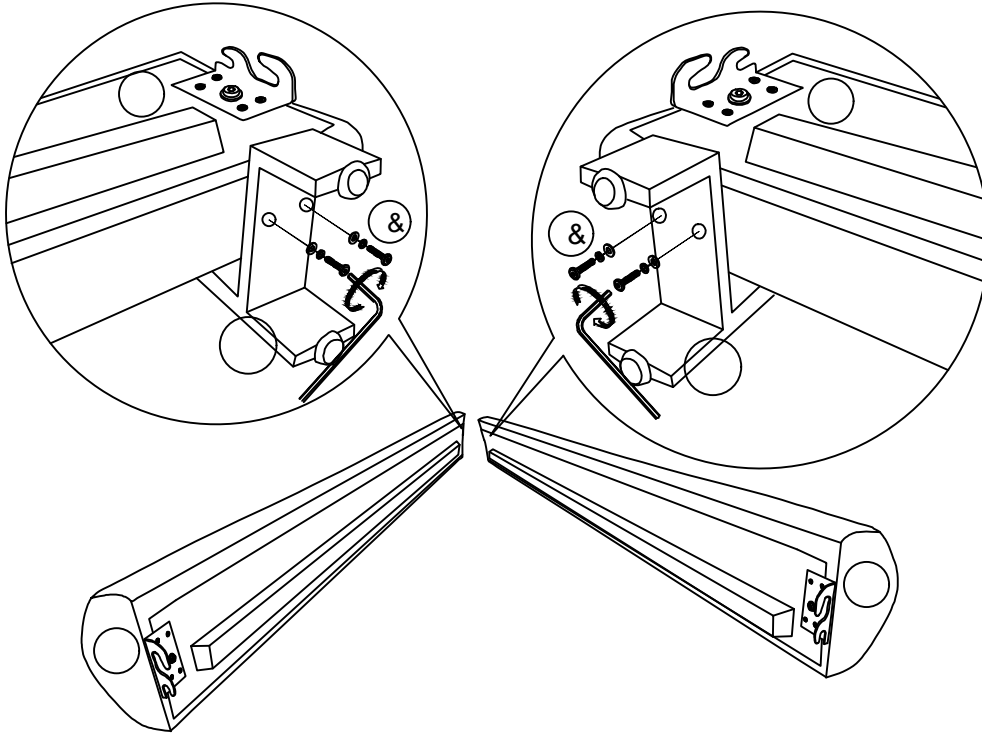

Step 3: Attach the Bed Leg (9) to the Side Panel (R) (1) and the Side Panel (L) (2). By using the Bolts (C), the Flat Washer (F) and the Spring washers (E) with M4 Allen Wrench (M) to connect the Bed Leg and the Side Panel.

# 6 W H S

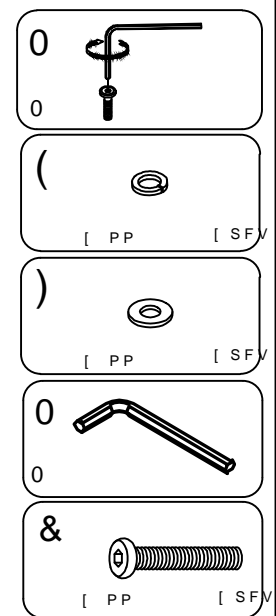
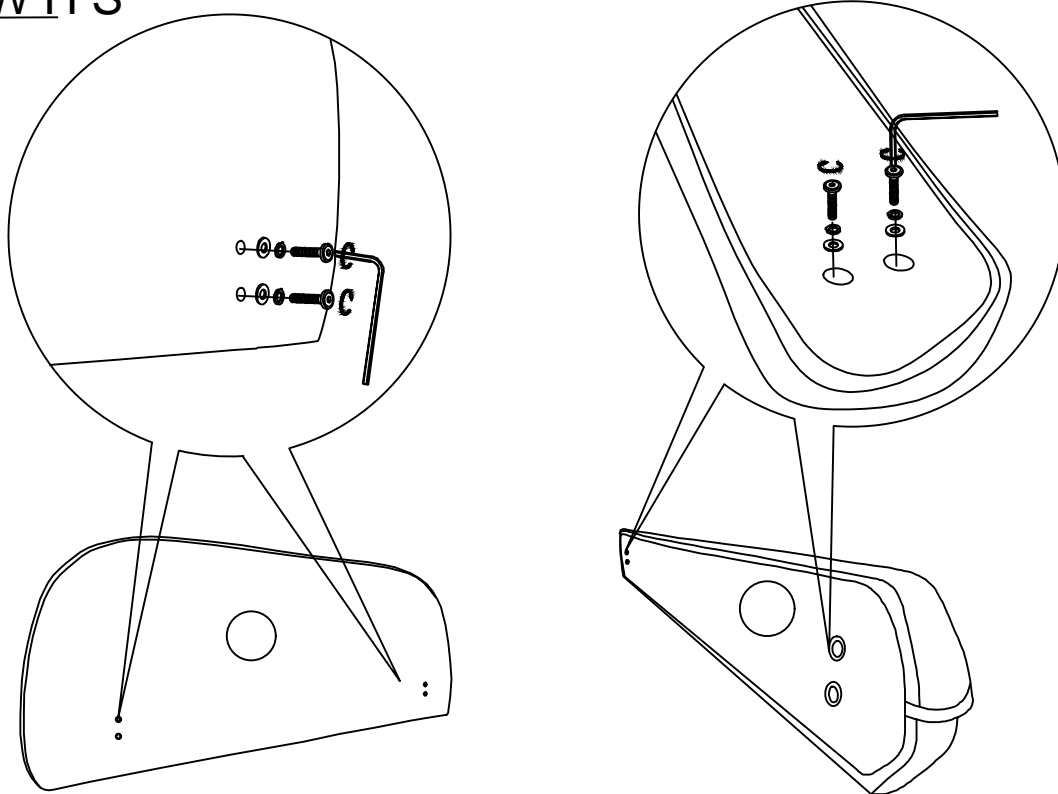

Step 4: Use Bolts (C) and Spring Washer (E) with Flat Washer (F). Then attach 1/2 Bolts (C) to the headboard (4) and Footboard (3)

# 6 W H S

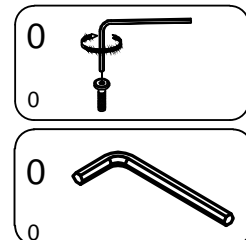
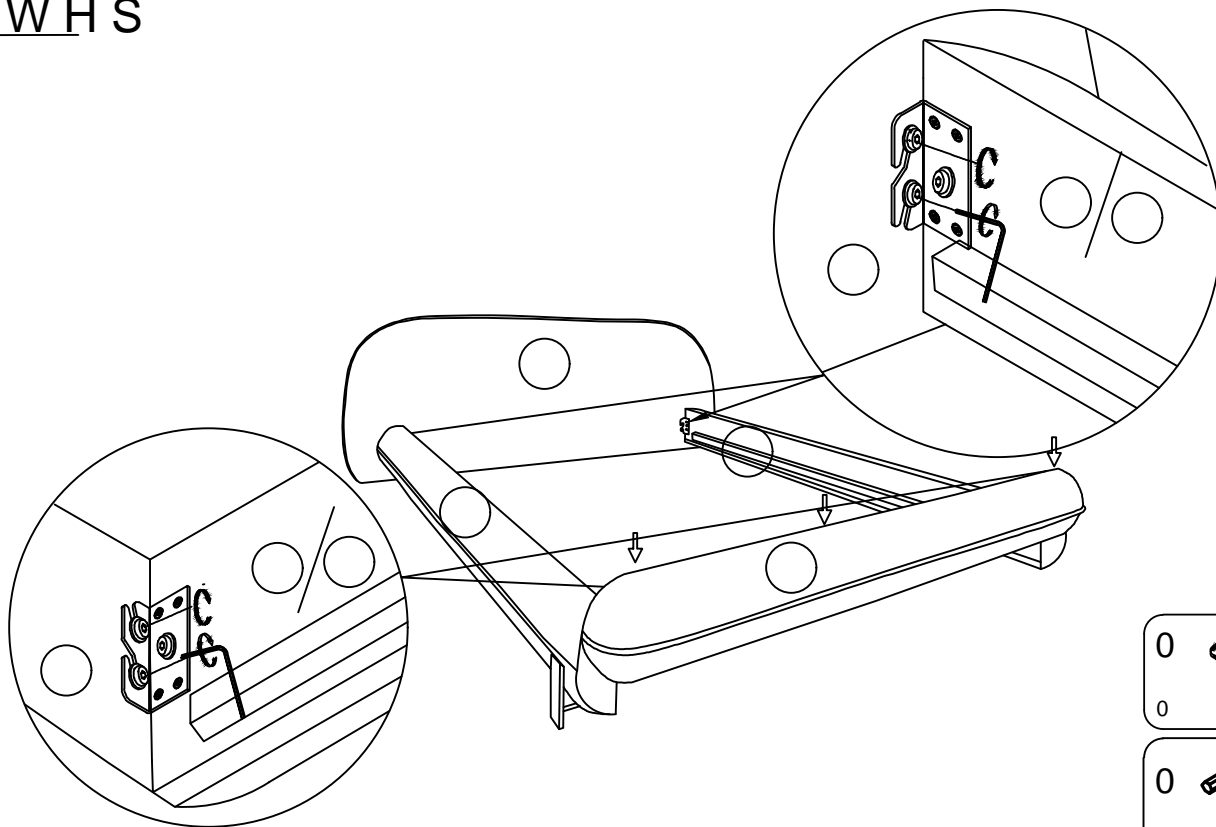

Step 5: Attach the Side Panel (1) and the Side Panel (2) to the Headboard (4) (Note: the direction of the Hinge is down), by using M4 Allen Wrench (M) to tighten the Bolts (C). Then attach the Footboard (3) to the Side Panel (1) and the Side Panel (2) (Note: the direction of the Hinge is up), by using M4 Allen Wrench (M) to tighten the Bolts (C).

# 6 W H S

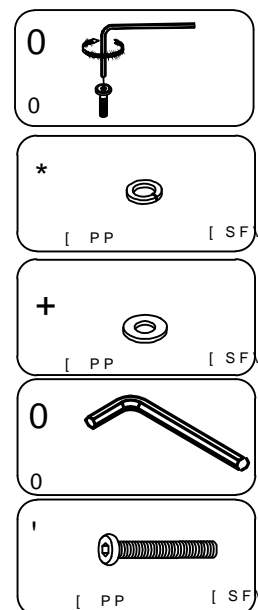
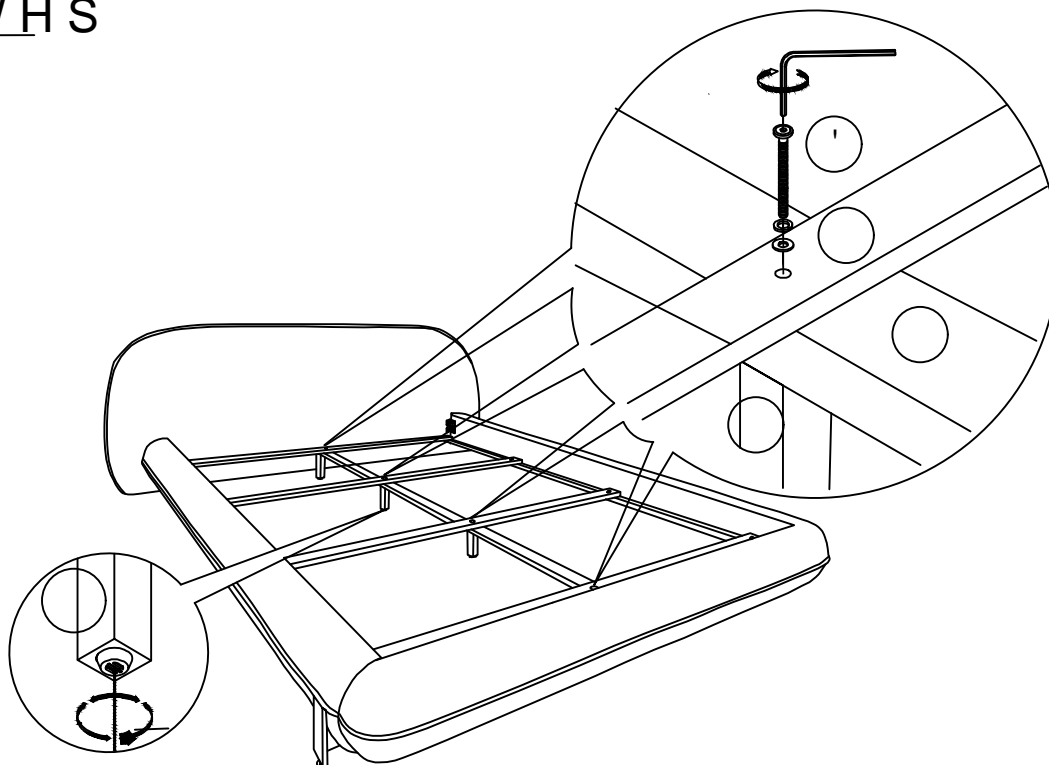

Step 6: Align the assembly position on the Center Support Bar (8) with the Center Support Bar Fitting (7) and the Slats (5). Then attach the Slats (5) and the Center Support Bar (8) to the Center Support Bar Fitting (7) . By using the Bolts (D) with M4 Allen Wrench (M).

# 6 W H S

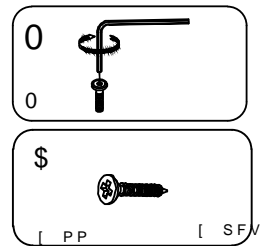
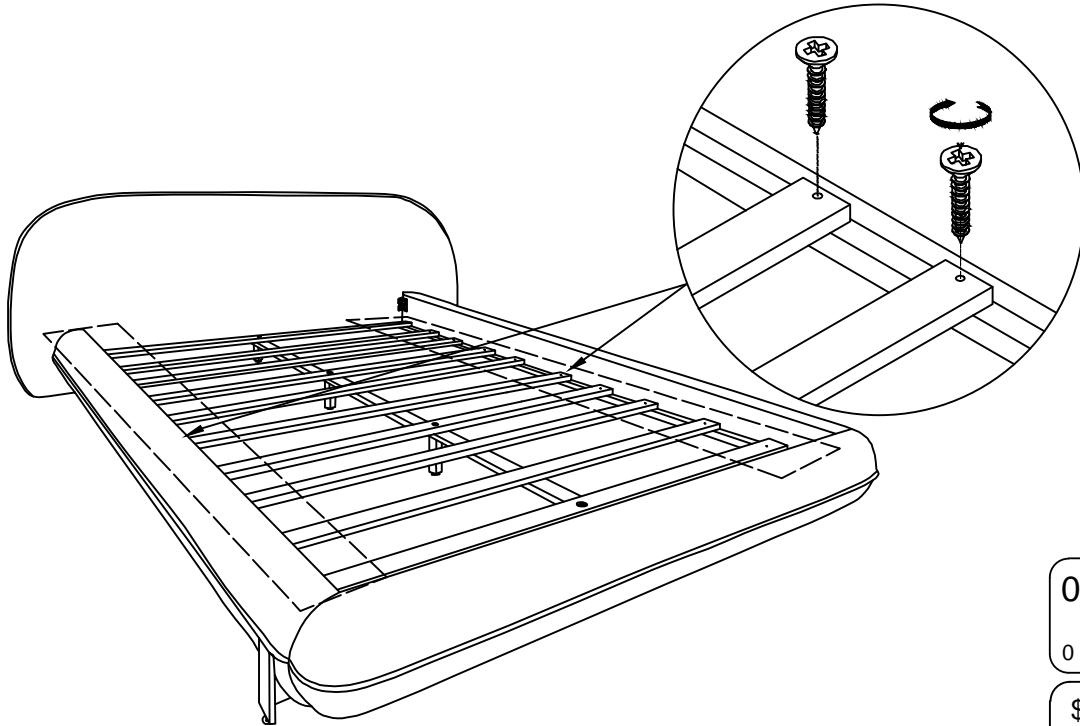

Step 7: Use the Screws (A) to fasten the Slats (5) and the Slats (6) to the Side Panel (R) (1) and the Side Panel (L) (2).

# 6 W H S

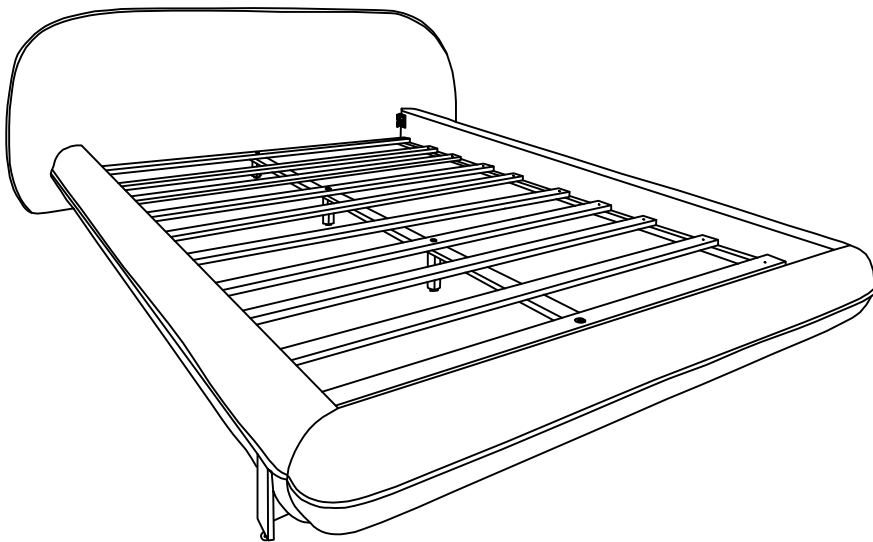

7KDQN \RX IRU \RXU WUXVW DQG SUHIHUHQFH LQ XVLQJ RXU SURGX  
IRUHYHU