

# ASSEMBLY INSTRUCTIONS

## LED EASTERN KING HEADBOARD

**A** Headboard Panel

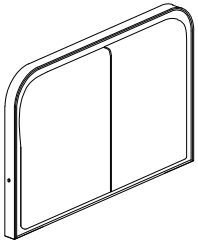

1PC

**B** Headboard Leg LSF  
(In 437BK-3)

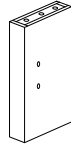

1PC

**C** Headboard Leg RSF  
(In 437BK-3)

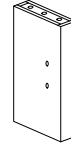

1PC

**D** Metal Bracket (black)  
(In the Headboard Leg)  
258 x 95 x 37 x 2mm

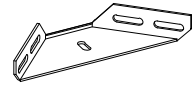

2PCS

**E** Threaded Rod  
Ø5/16" x 3 1/4"

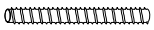

**F** Bolt  
Ø5/16" x 25mm

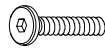

**G** Flat Washer  
Ø5/16" x 22mm

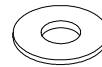

**H** Lock Washer  
Ø5/16" x 12mm



**I** 6PCS  
Hex Nut  
Ø5/16" x 12 x 5mm



**J** 8PCS  
Wrench  
M5 x 90mm

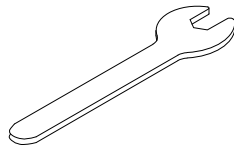

**K** 14PCS  
L-Allen Key  
5mm

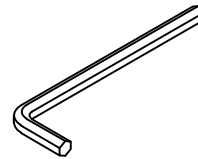

14PCS

6PCS

1PC

1PC

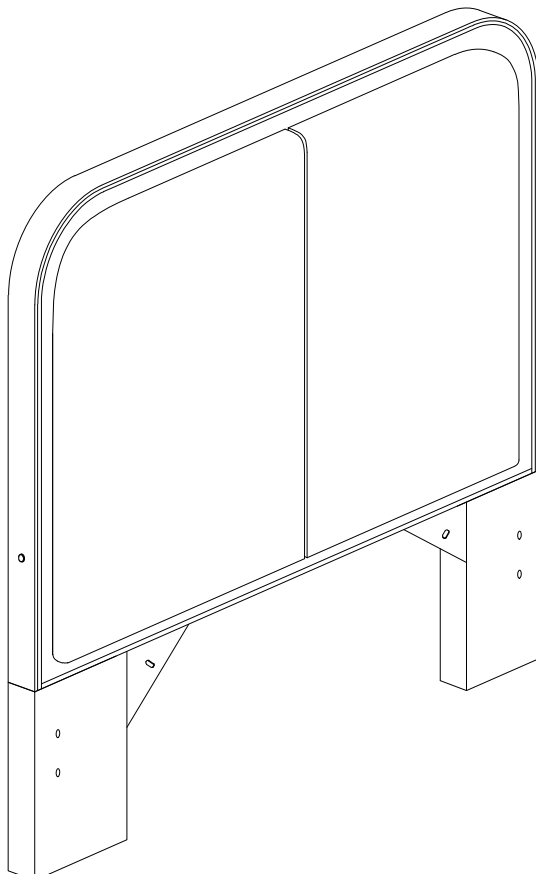

This page lists all the contents included in the box. Please take the time to identify the hardware as well as the individual components to this product. As you unpack and prepare for assembly, place the contents on a carpeted or padded area to protect them from damage.

- 1** Attach LSF & RSF Headboard Leg (B & C) to Headboard (A) using Threaded Rod (E), Flat Washer (G), Lock Washer (H) and Hex Nut (I) with Wrench (J).

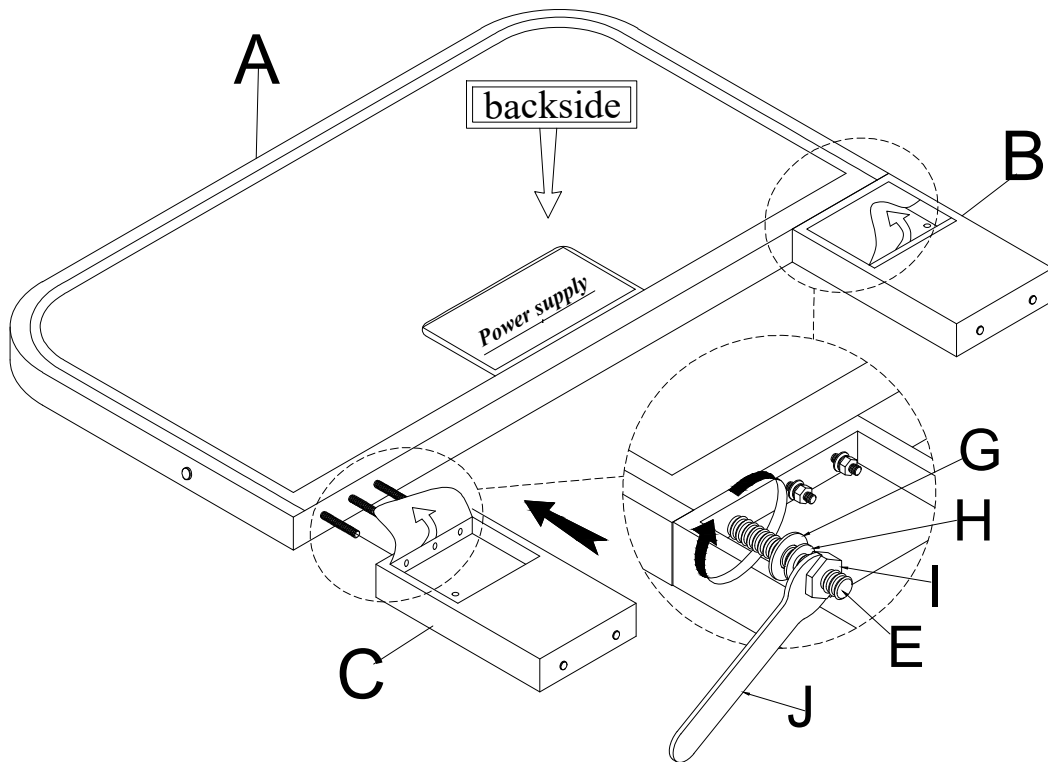

- 2** Attach Metal Bracket (D) to Headboard (A) and LSF & RSF Headboard Leg (B & C) using Bolt (F), Lock Washer (H) and Flat Washer (G) with L-Allen Key (K).

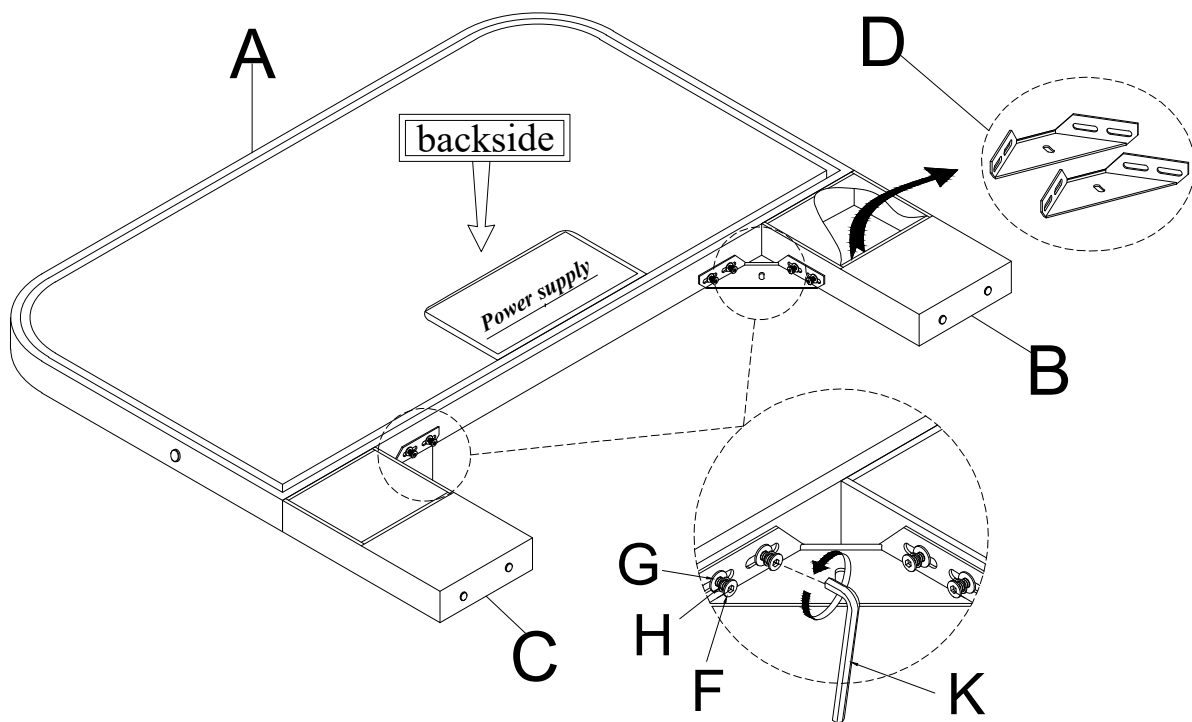







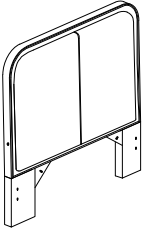
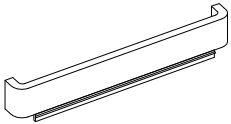
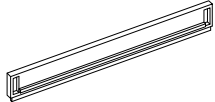
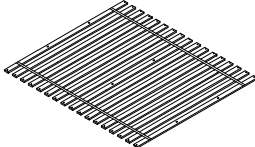
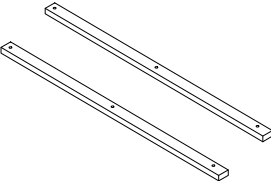
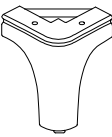
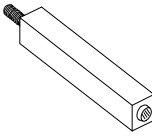
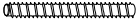

#### Cleaning & Care

Treat surfaces with care. Surfaces are resistant to scratches but are not scratch resistant. Clean surfaces with a dry or damp soft cloth. Do not use abrasive cleaners. Hardware may loosen over time. Periodically check that all connections are tight.

# ASSEMBLY INSTRUCTIONS

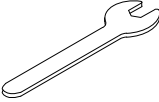
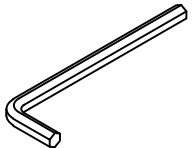
## LED EASTERN KING FOOTBOARD & RAILS & SLATS & SUPPORT LEGS & CENTER BARS

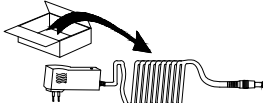
<b>A</b> Headboard (In 437BK-1)  1PC	<b>B</b> Footboard Panel  1PC	<b>C</b> Side Rail  2PCS	<b>D</b> Slat  1SET (17PCS)	<b>E</b> Center Bar  2PCS
<b>F</b> Footboard Leg  2PCS	<b>G</b> Center Support Leg  6PCS	<b>H</b> Threaded Rod Ø5/16" x 80mm  8PCS	<b>I</b> Bolt 5/16" x 50mm  4PCS	<b>J</b> Flat Washer 5/16" x 22mm  8PCS
<b>K</b> Flat Washer 5/16" x 19mm  4PCS	<b>L</b> Lock Washer 5/16" x 12mm  12PCS	<b>M</b> Hex Nut 5/16" x 12 x 5mm  8PCS	<b>N</b> Wrench M5 x 90mm  1PC	<b>O</b> L-Allen Key 5mm  1PC
<b>P</b> Screw Ø8 x 38mm  34PCS	<b>Q</b> Electricity Plug  1PC			

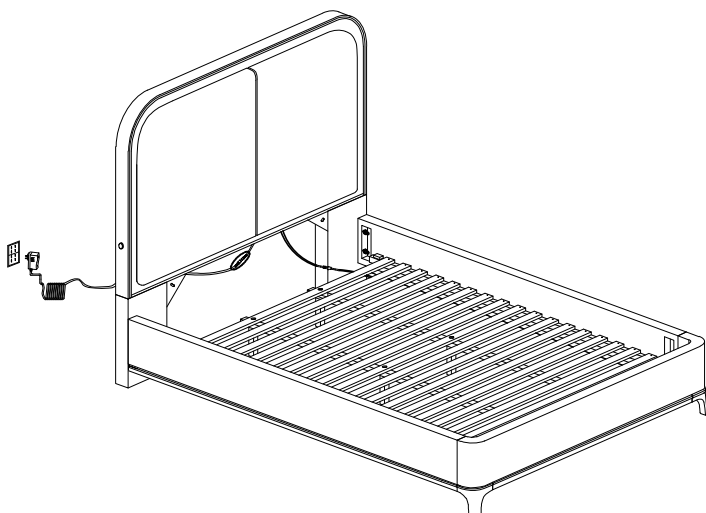

This page lists all the contents included in the box. Please take the time to identify the hardware as well as the individual components to this product. As you unpack and prepare for assembly, place the contents on a carpeted or padded area to protect them from damage.

**1** Attach Footboard Leg (F) to Footboard Panel (B) using Bolt (I), Lock Washer (L) and Flat Washer (K) with L-Allen Key (O).

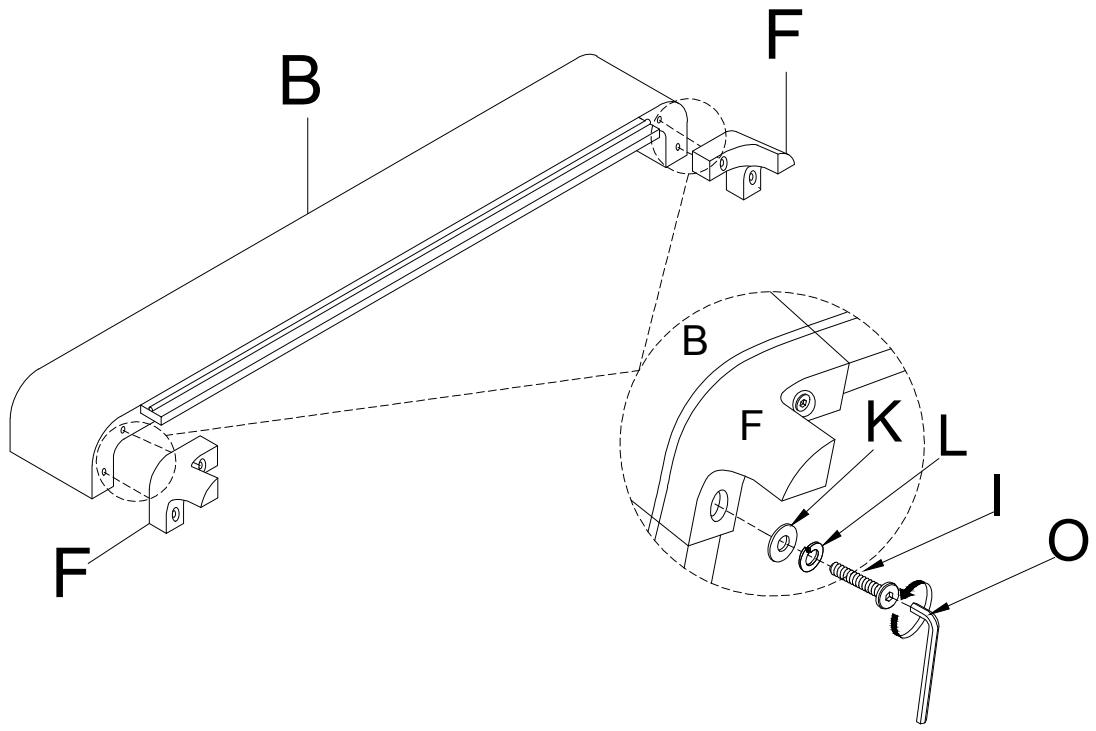

**2** Attach Side Rail (C) to Headboard (A) and Footboard (B) using Threaded Rod (H), Flat Washer (J), Lock Washer (L) and Hex Nut (M) with Wrench (N).

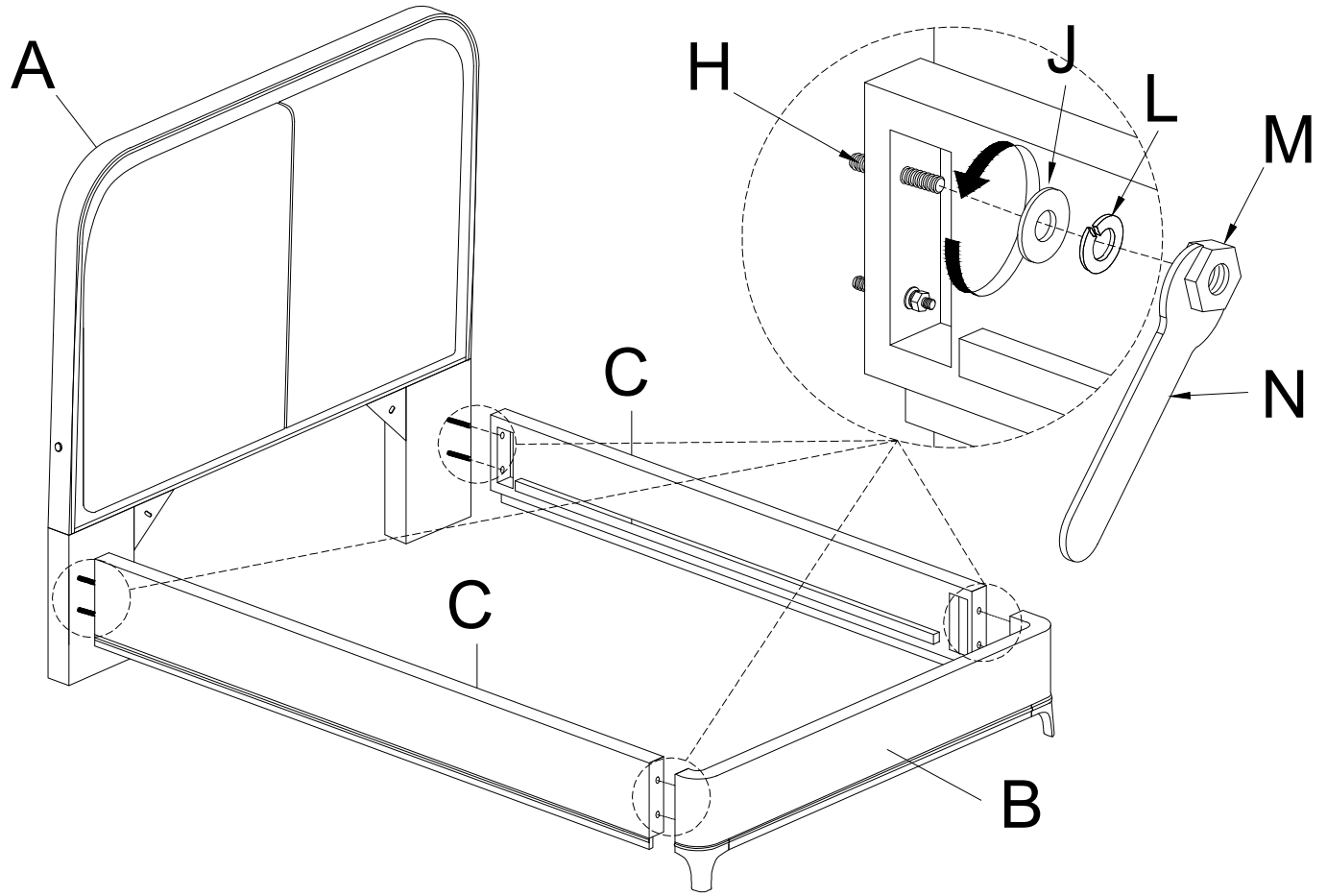

**3**

Rotate and attach Center Bar (E) and Center Support Leg (G) to Slat (D).

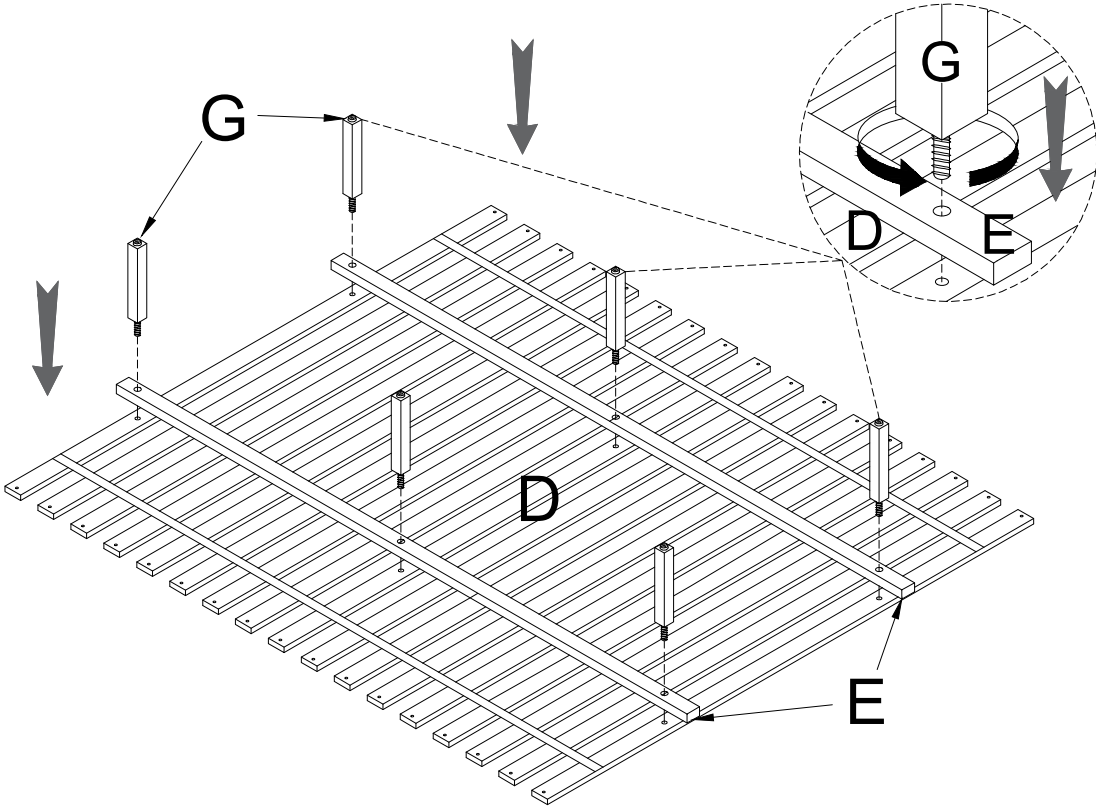

**4**

Attach Slat (D) to Side Rail (C) using Screw (P) with a screwdriver (not provided).

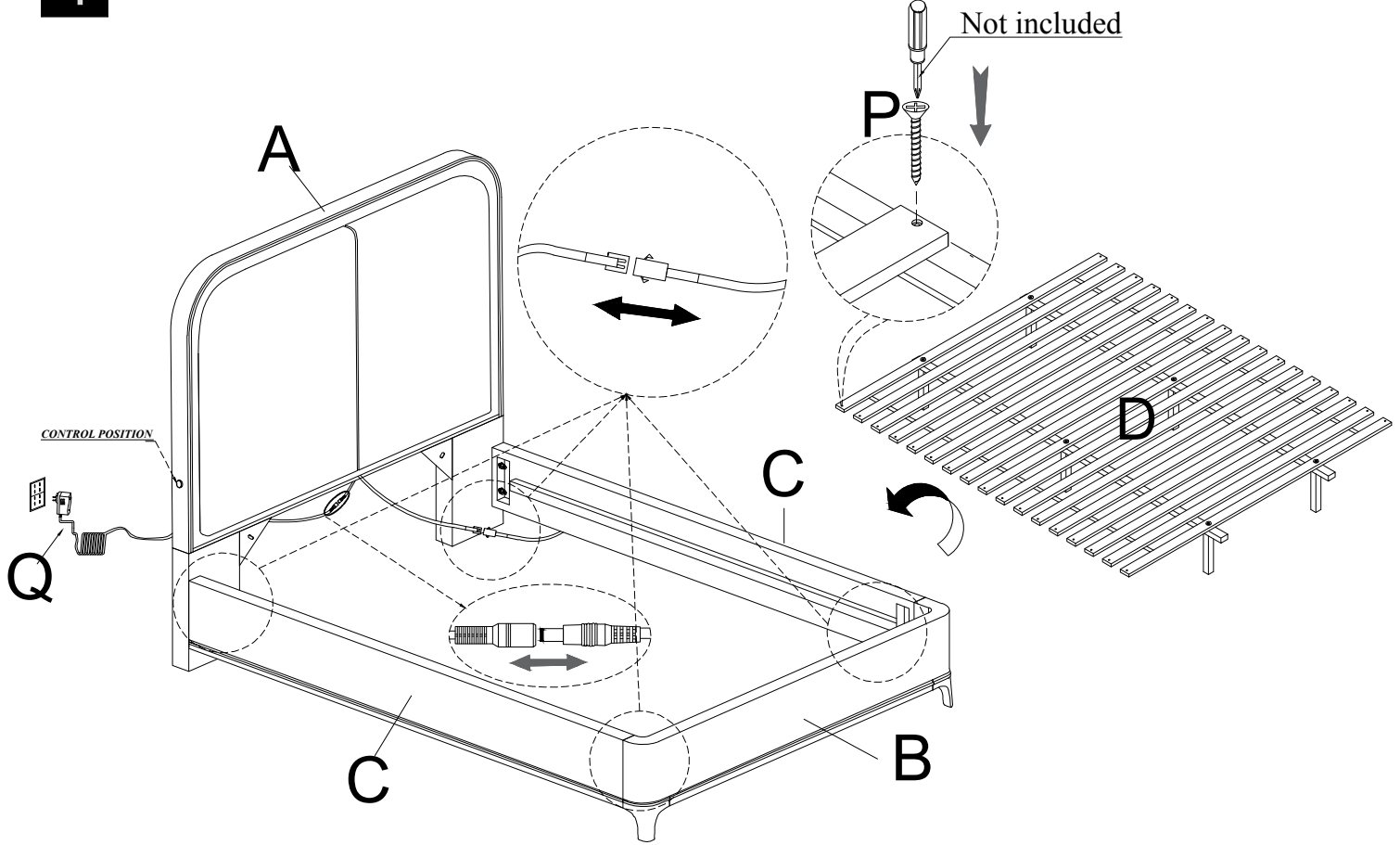

**Cleaning & Care**

Treat surfaces with care. Surfaces are resistant to scratches but are not scratch resistant. Clean surfaces with a dry or damp soft cloth. Do not use abrasive cleaners. Hardware may loosen over time. Periodically check that all connections are tight.