

ASSEMBLY INSTRUCTIONS

Thank you for purchasing this product. Please take time to read and follow the instructions below. Check that you have all parts and hardware before assembly. Parts apparently missing are often found in the packing materials. If you do not have all the parts listed, have your dealer contact us and they will be sent to you immediately.

It is recommended to install protective pads under all legs and supports to avoid damage or scratches when placing furniture on a wood floor or other hard surface, and to limit indentation and prevent discoloration if placing on carpet.



PARTS LIST

NO:	DESCRIPTION	Q'TY/QTÉ
1	Cushion seat	1PC
2	Leg	4PCS
3	Stretcher	1PC

HARDWARE LIST

NO:	DESCRIPTION	SIZE	Q'TY/QTÉ
A	Bolt	Ø1/4" x 35mm	12PCS
B	Spring washer	Ø8 x 13mm	12PCS
C	Flat washer	Ø8 x 19mm	12PCS
D	Allen key	Ø4 x 59mm	1PC

Step 1

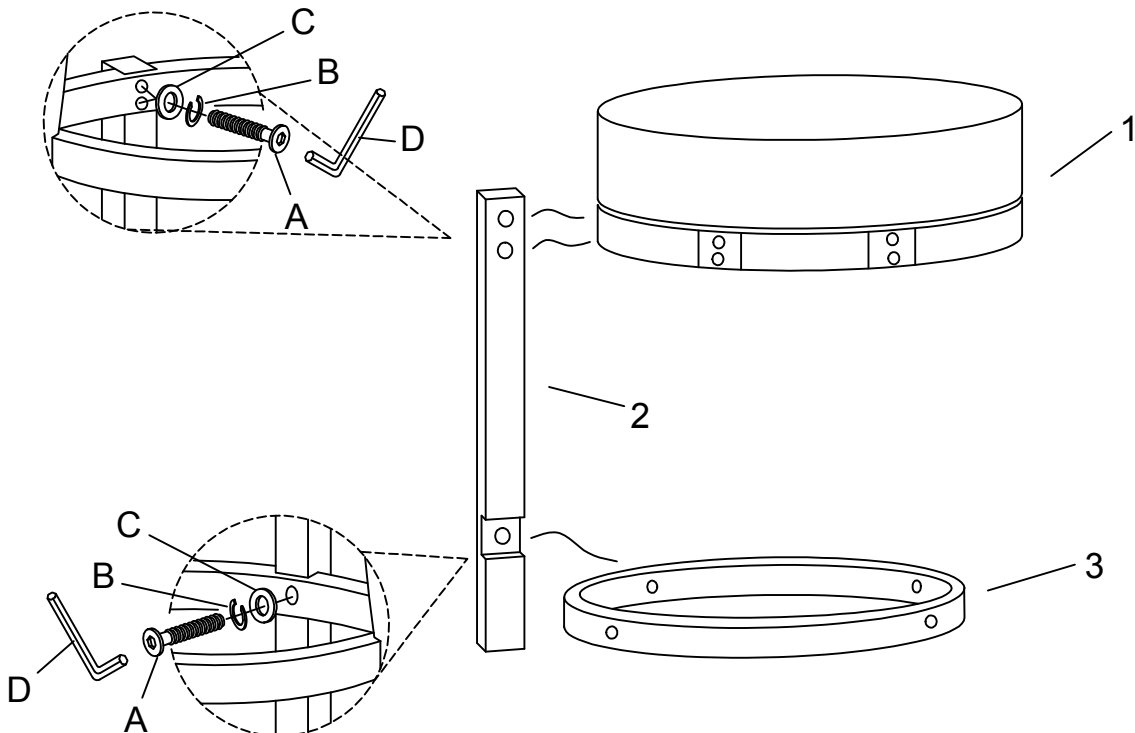

Step 3

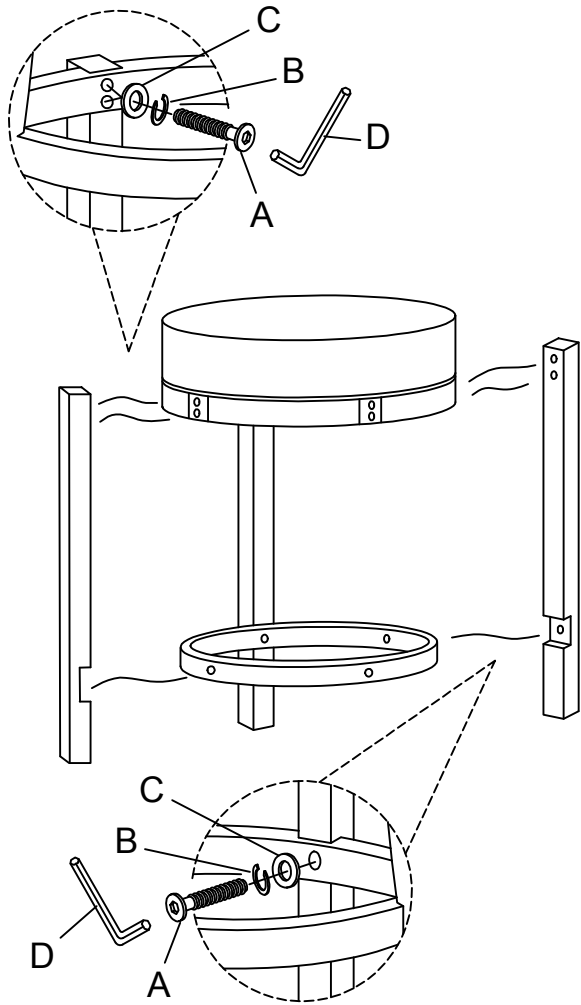

Step 4

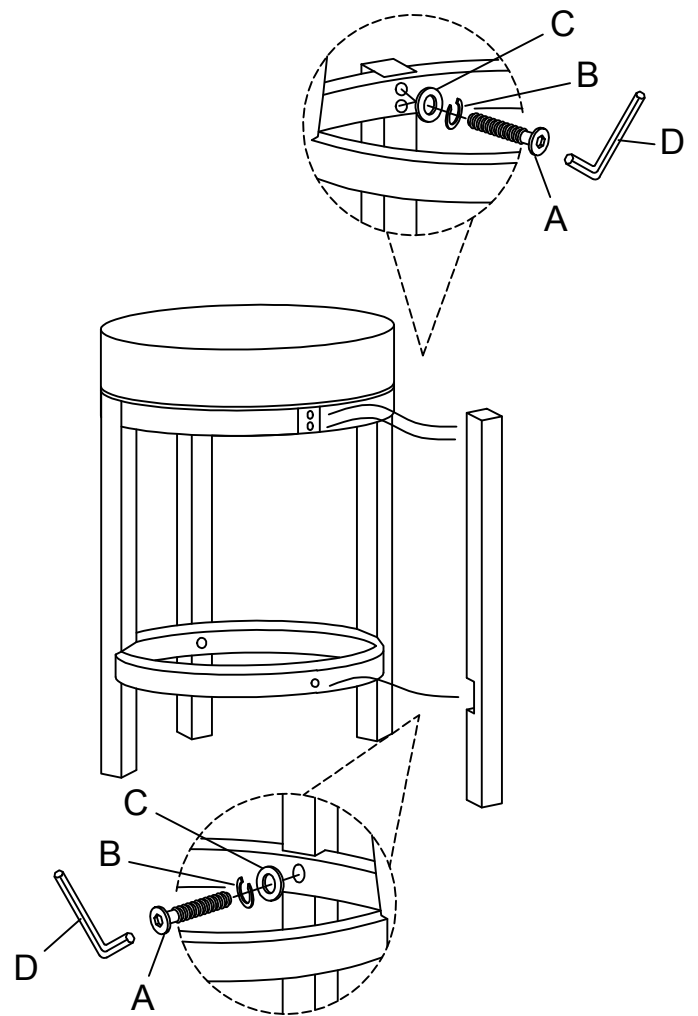

Assembly Completed

