

ASSEMBLY INSTRUCTIONS
COASTER FINE FURNITURE

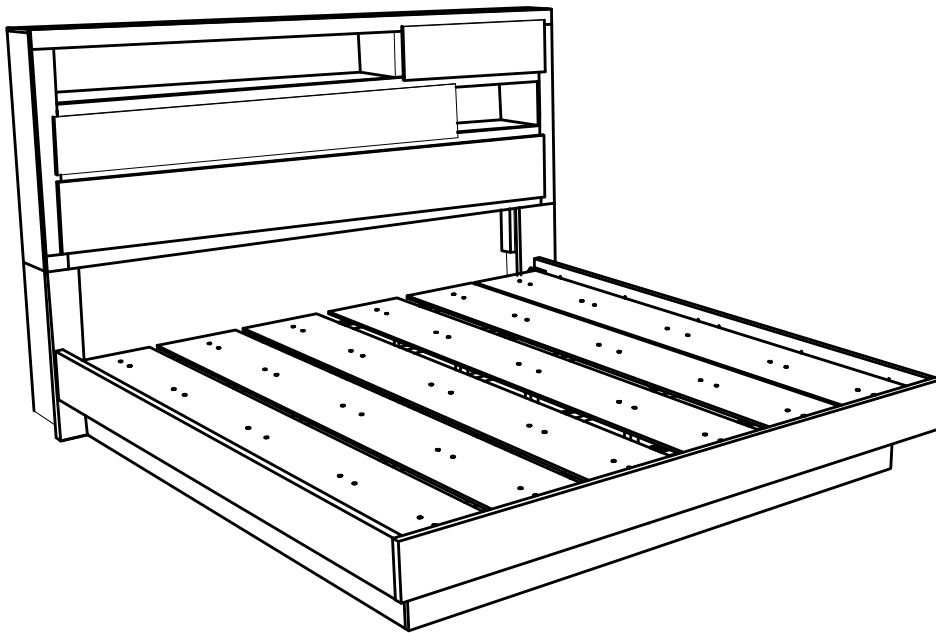

Fine Furniture for every stage of life

224981KE(B1-B3)
Eastern King Bed

ITEM: 224981KE(B1-B3)



ASSEMBLY INSTRUCTIONS

ASSEMBLY TIPS:

1. Remove hardware from box and sort by size.
2. Please check to see that all hardware and parts are present prior to start of assembly.
3. Please follow attached instructions in the same sequence as numbered to assure fast & easy assembly.



WARNING!

1. Don't attempt to repair or modify parts that are broken or defective. Please contact the store immediately.
2. This product is for home use only and not intended for commercial establishments.



ASSEMBLY TIME

20 MINUTES

PARTS IDENTIFICATION

B1 (BOX 1)

A STORAGE HEADBOARD

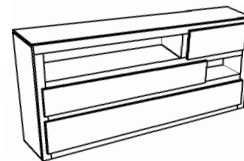

1PC

B LEFT HEADBOARD LEG

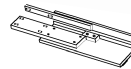

1PC

C RIGHT HEADBOARD LEG

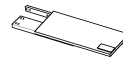

1PC

B2 (BOX 2)

D FOOTBOARD

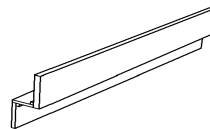

1PC

B3 (BOX 3)

E BED SLAT WITH MARKING

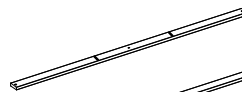

2PCS

F BED SLAT WITHOUT MARKING



3PCS

G BED SLAT SUPPORT WITH LEVELER

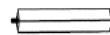

10PCS

H BED RAIL



2PCS

I BED RAIL BASE PANEL



2PCS

J TRESTLE BAR



1PC

K CONCEAL PANEL



5PCS

**HB 224981KE(B1) FROM BOX 1
HEADBOARD COMPLETE**



1PC

**D 224981KE(B2) FROM
BOX 2 FOOTBOARD**

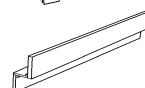

1PC

ITEM:224981KE(B1-B3)



ASSEMBLY INSTRUCTIONS

ASSEMBLY TIPS:

1. Remove hardware from box and sort by size.
2. Please check to see that all hardware and parts are present prior to start of assembly.
3. Please follow attached instructions in the same sequence as numbered to assure fast & easy assembly.







WARNING!





1. Don't attempt to repair or modify parts that are broken or defective. Please contact the store immediately.
2. This product is for home use only and not intended for commercial establishments.

HARDWARE IDENTIFICATION

Z-B1(BOX 1) - HARDWARE PACK IS LOCATED IN 224981KE (B1)

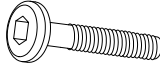
1	SHORT BOLT (M6 x 30mm - BLK)		12PCS
2	LOCK WASHER (1/4" - BLK)		12PCS
3	FLAT WASHER (1/4" x 19mm - BLK)		12PCS
4	SMALL ALLEN WRENCH (M4 x 65mm - BLK)		1PC

Z-B3(BOX 3) - HARDWARE PACK IS LOCATED IN 224981KE (B3)

5	LONG BOLT (M6 x 50mm - BLK)		10PCS
6	FLAT HEAD SCREW (M4 x 32mm - BLK)		12PCS
7	PAN HEAD SCREW (M3.5x 20mm - BLK)		30PCS
8	SMALL ALLEN WRENCH (M4 x 65mm - BLK)		1PC
9	BIG ALLEN WRENCH (M5 x 65mm - BLK)		1PC

NOTE:

Phillips head screw driver is required in the assembly process; however, manufacturer does not provide this item.

ITEM: **224981KE(B1-B3)**



ASSEMBLY INSTRUCTIONS

STEP 1

Note : Please put item on soft surface.
Please take note of the marking sticker (L&R) on the leg.

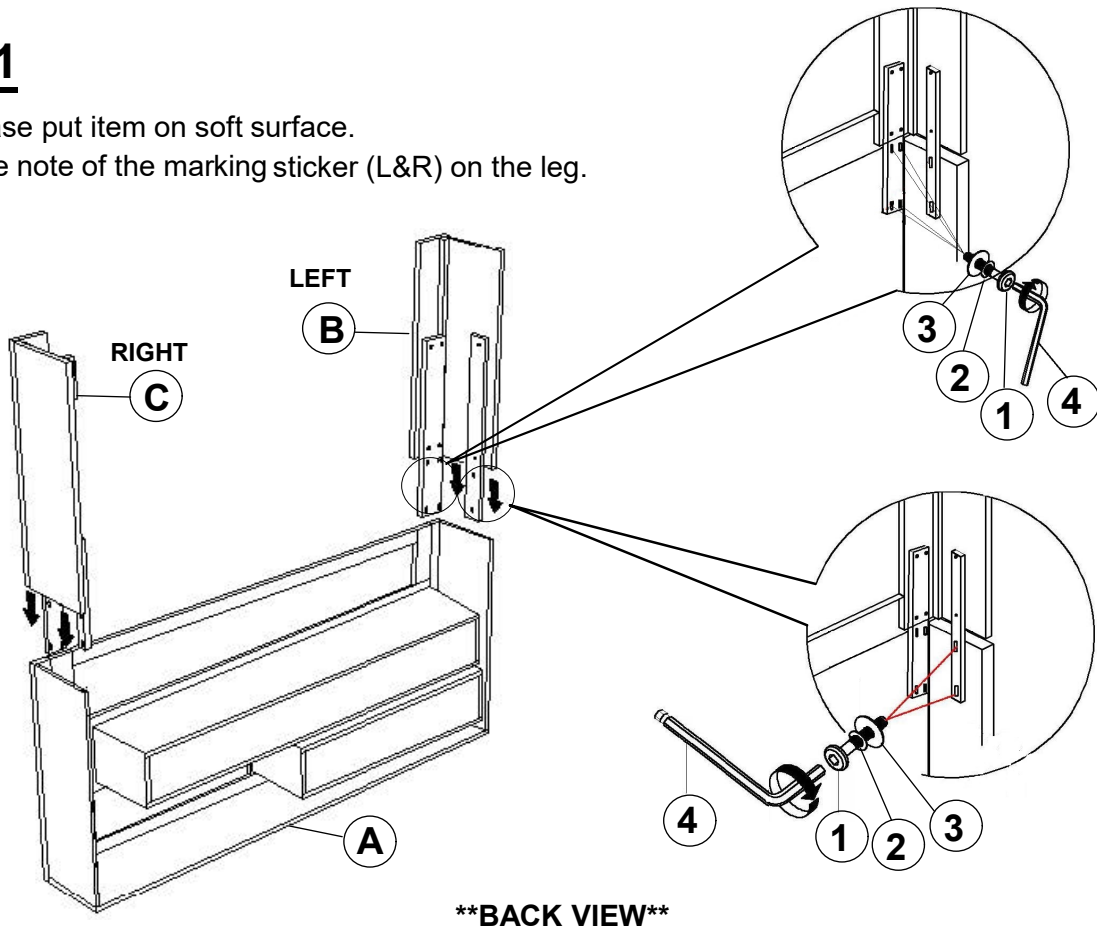

STEP 2

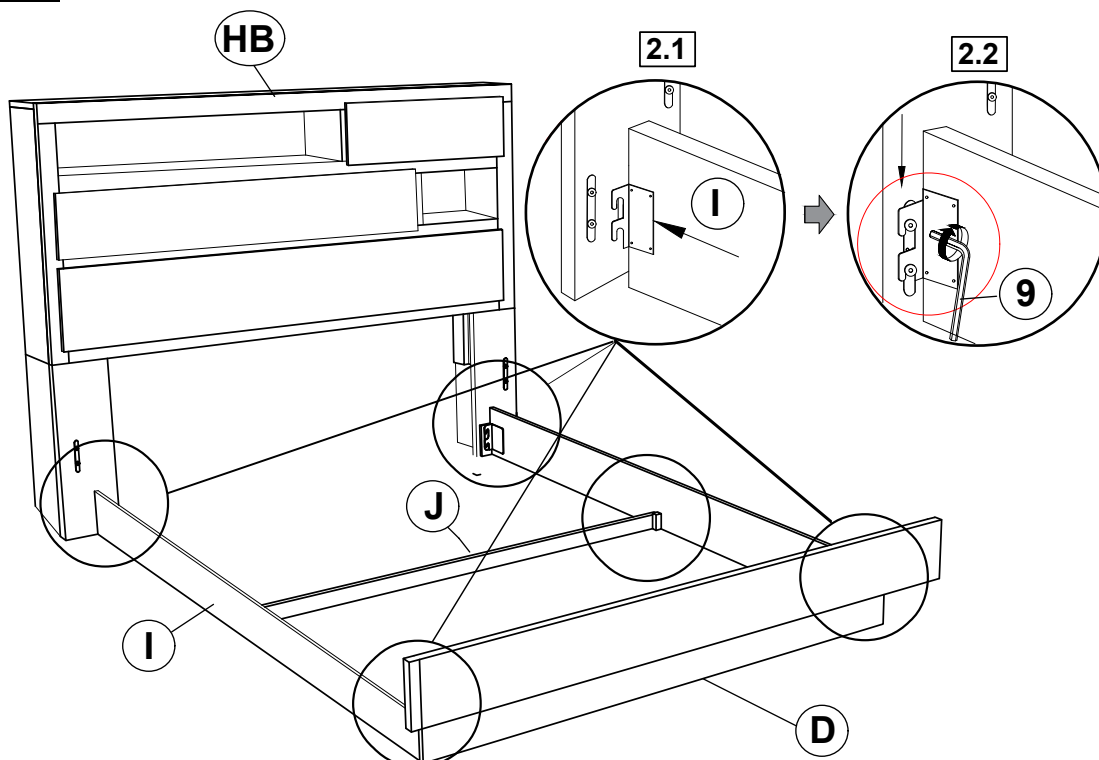

ASSEMBLY INSTRUCTIONS

STEP 3

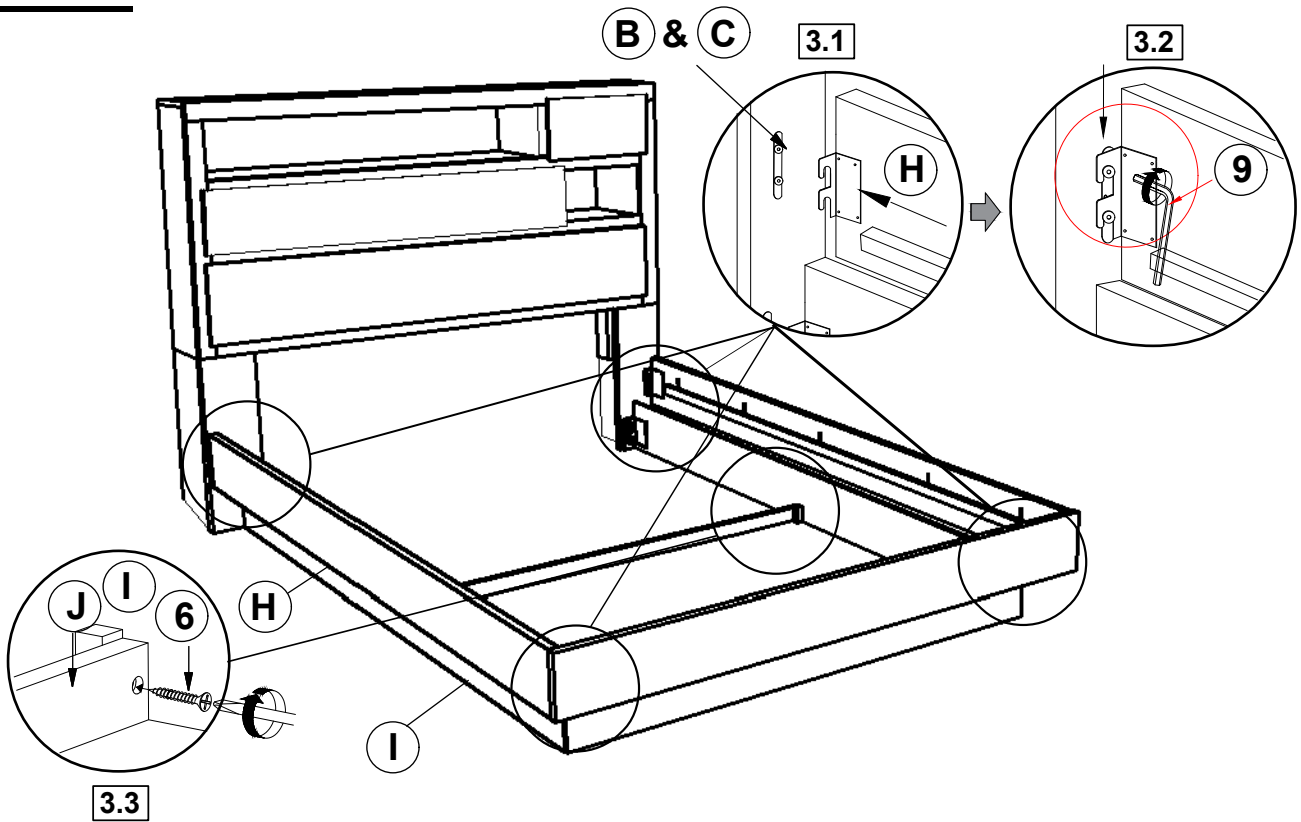

STEP 4

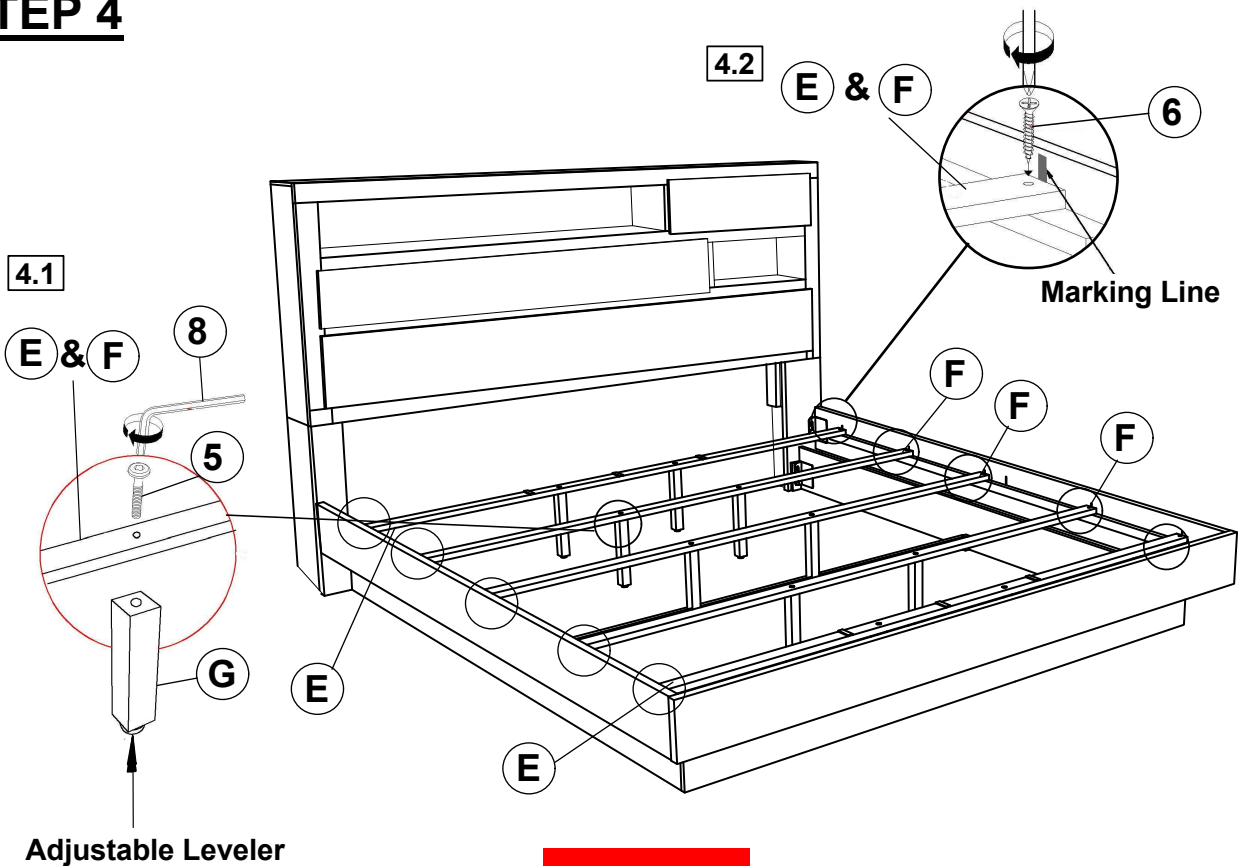

ASSEMBLY INSTRUCTIONS

STEP 5

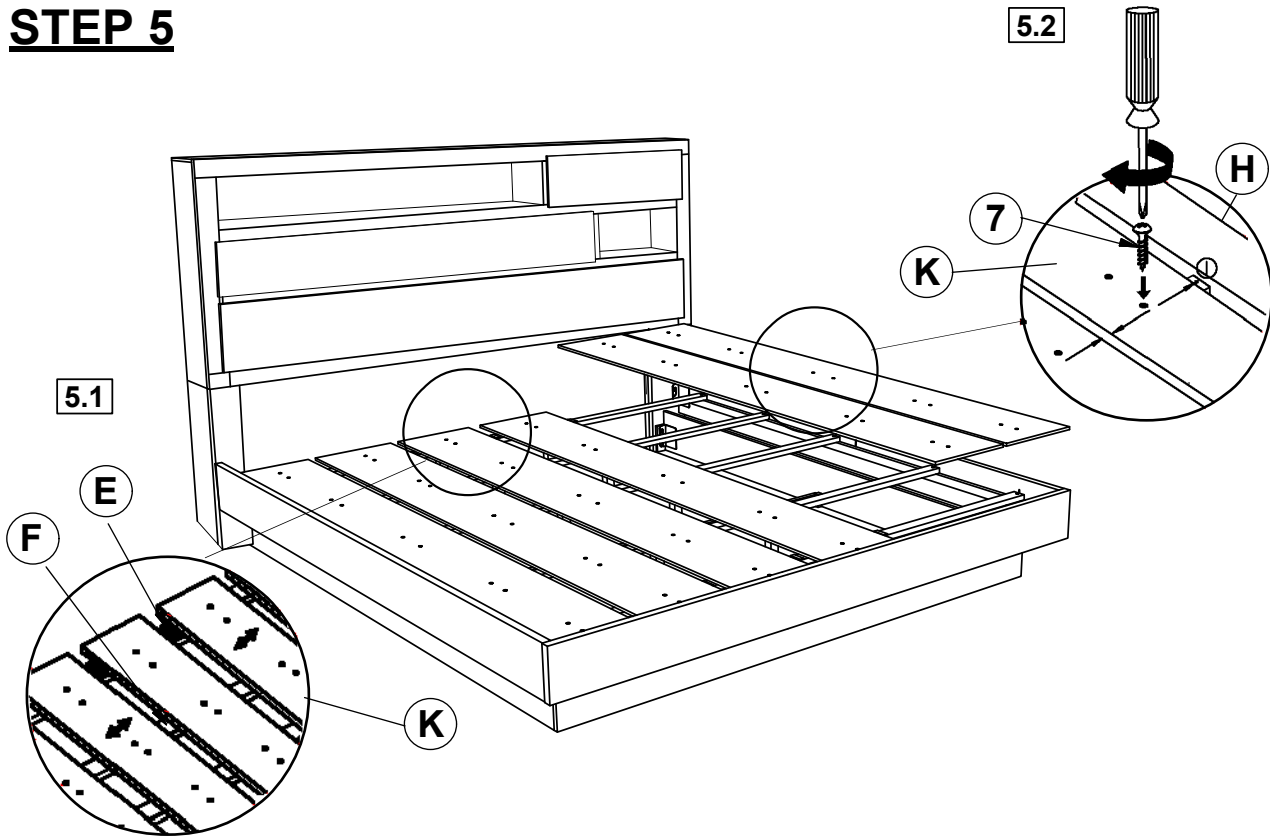

STEP 6
COMPLETE

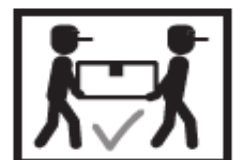
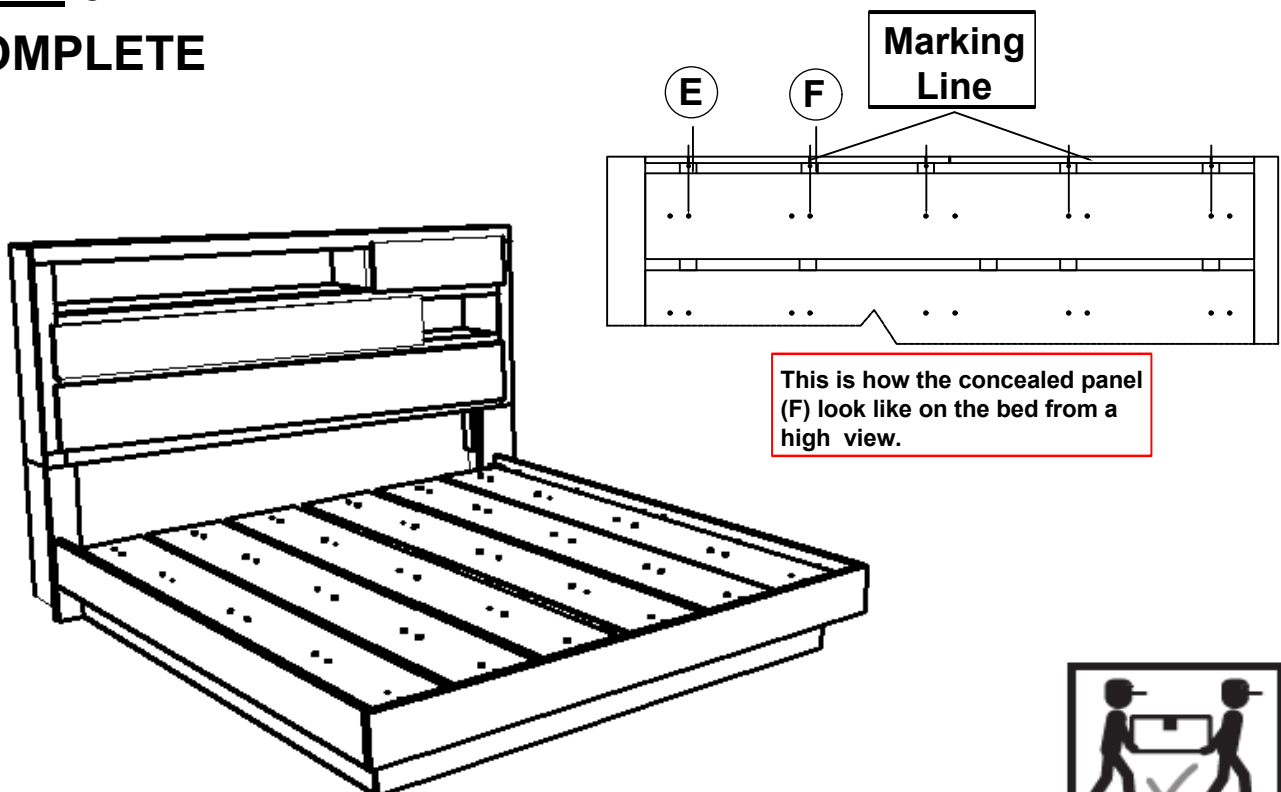

ITEM: 224981KE(B1-B3)



Inner Size : 77.00"W x 80.75"D

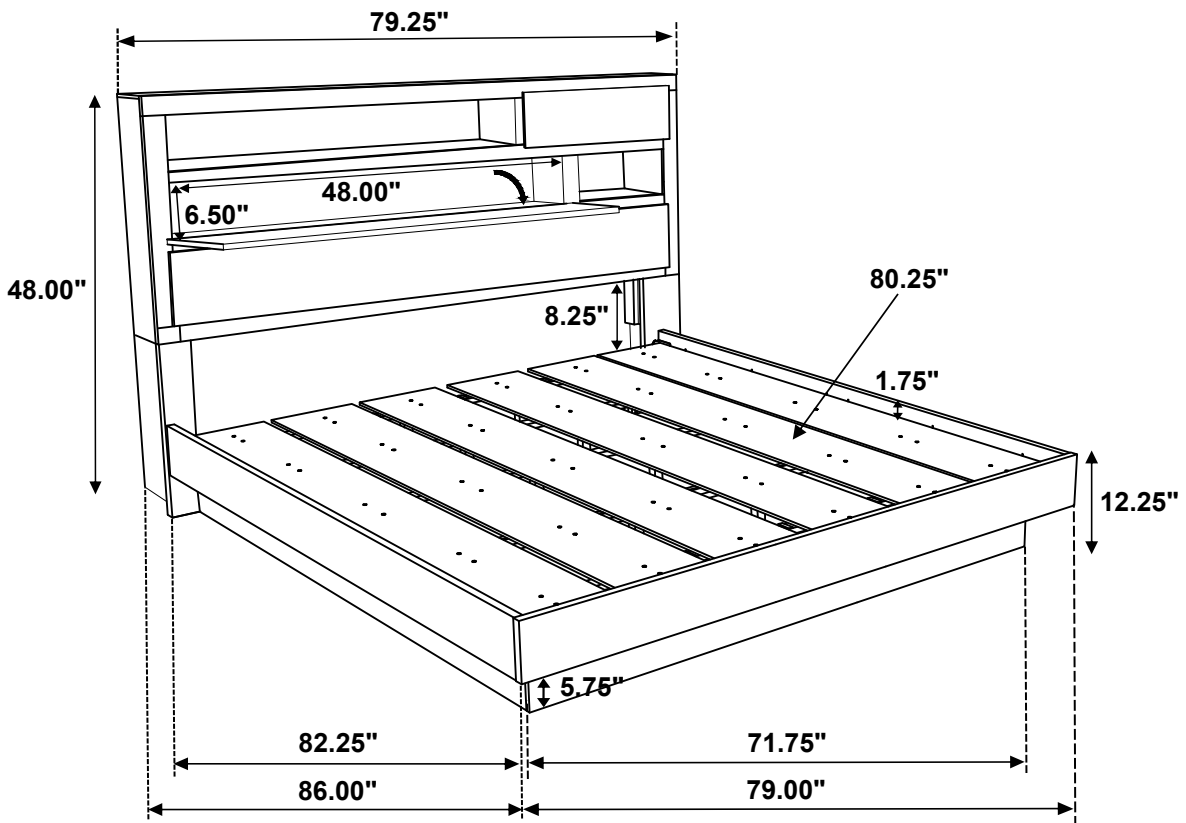
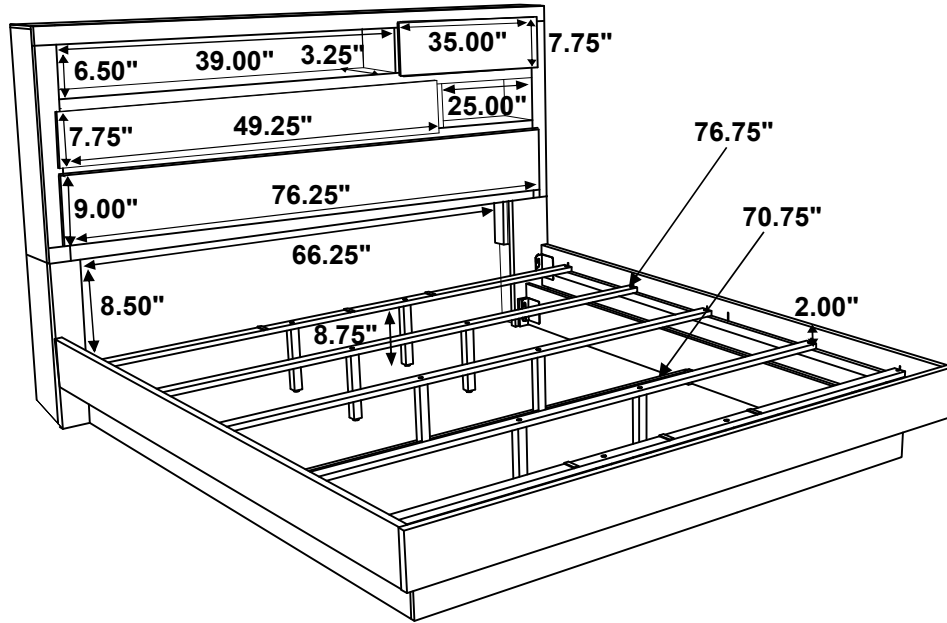

Note : Dimension tolerance $\pm 5\%$