

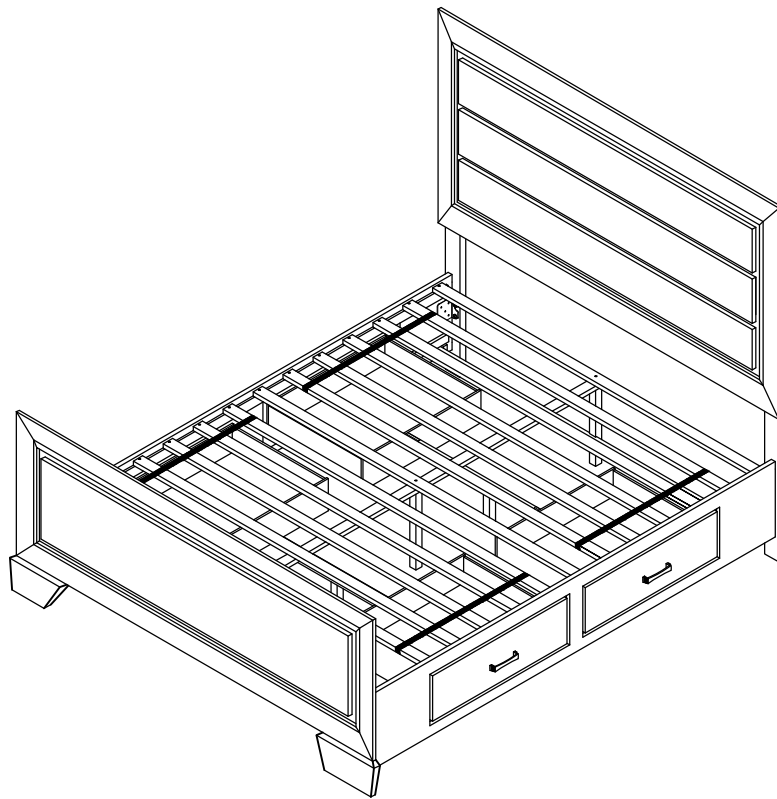

ASSEMBLY INSTRUCTIONS COASTER FINE FURNITURE



Fine Furniture for every stage of life

204190Q(B1-B4) **Queen Storage Bed**

REVISION 0 : 04/08/2016
REVISION 1 : 11/14/2016
REVISION 2 : 11/12/2019

ITEM: 204190Q(B1-B4)

ASSEMBLY INSTRUCTIONS

ASSEMBLY TIPS:

- 1 . Remove hardware from box and sort by size.
- 2 . Please check to see that all hardware and parts are present prior to start of assembly.
- 3 . Please follow attached instructions in the same sequence as numbered to assure fast & easy assembly.



WARNING !

- 1 . Don't attempt to repair or modify parts that are broken or defective. Please contact the store immediately.
- 2 . This product is for home use only and not intended for commercial establishment.



ASSEMBLY TIME



30 MINUTES

PARTS IDENTIFICATION

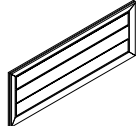
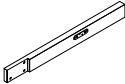
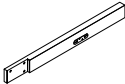
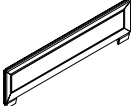
B1 (BOX 1)

A	HEADBOARD PANEL		1PC
B	LEFT HEADBOARD LEG		1PC
C	RIGHT HEADBOARD LEG		1PC
D	FOOTBOARD		1PC

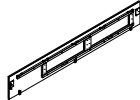
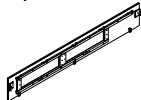
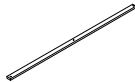
B2 (BOX 2)

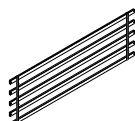
E	LEFT BED RAIL		1PC
F	RIGHT BED RAIL		1PC
G	BED SLAT WITH 3 HOLES		3PCS
H	DRAWER SLAT		2PCS
I	ROLL SLAT (5PCS)		2SETS

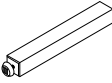
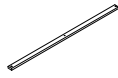
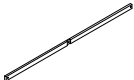
J	STORAGE FOOTBOARD SUPPORT LEG		2PCS
K	CENTER RAIL SUPPORT WITH LEVELER		3PCS
L	CENTER RAIL		1PC
M	BOTTOM CROSS BAR		3PCS

B3 (BOX 3)

N	DRAWER BOX		2PCS
---	------------	---	------

B4 (BOX 4)

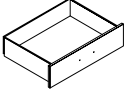
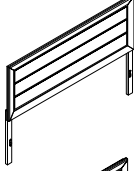
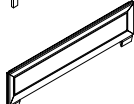
O	DRAWER BOX		2PCS
HB	204190Q (B1) FROM BOX 1 HEADBOARD COMPLETE		1PC
D	204190Q (B1) FROM BOX 1 FOOTBOARD		1PC

ITEM: 204190Q(B1-B4)

ASSEMBLY INSTRUCTIONS

ASSEMBLY TIPS:

- 1 . Remove hardware from box and sort by size.
- 2 . Please check to see that all hardware and parts are present prior to start of assembly.
- 3 . Please follow attached instructions in the same sequence as numbered to assure fast & easy assembly.



WARNING !

- 1 . Don't attempt to repair or modify parts that are broken or defective. Please contact the store immediately.
- 2 . This product is for home use only and not intended for commercial establishment.



ASSEMBLY TIME

30 MINUTES

HARDWARE IDENTIFICATION

Z-B1 (BOX 1) - HARDWARE PACK IS LOCATED IN 204190Q (B1)

1 BOLT
(M6 x30mm - BLK)



6PCS

3 FLAT WASHER
(1/4" x13mm - BLK)



6PCS

2 LOCK WASHER
(1/4" - BLK)



6PCS

4 ALLEN WRENCH
(M4 x 65mm - BLK)



1PC

Z-B2 (BOX 2) - HARDWARE PACK IS LOCATED IN 204190Q (B2)

5 BOLT
(M6 x50mm - BLK)

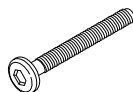

5PCS

8 SMALL ALLEN
WRENCH
(M4 x 65mm - BLK)



1PC

6 LONG FLAT HEAD
SCREW
(M4 x 32mm - RBW)



43PCS

9 BIG ALLEN
WRENCH
(M5 x 65mm - BLK)



1PC

7 SHORT FLAT HEAD
SCREW
(M4 x 16mm - RBW)



4PCS

NOTE:

Philips head screw driver in the assembly process ; however, manufacturer does not provide the item

ITEM: **204190Q(B1-B4)**
ASSEMBLY INSTRUCTIONS

STEP 1

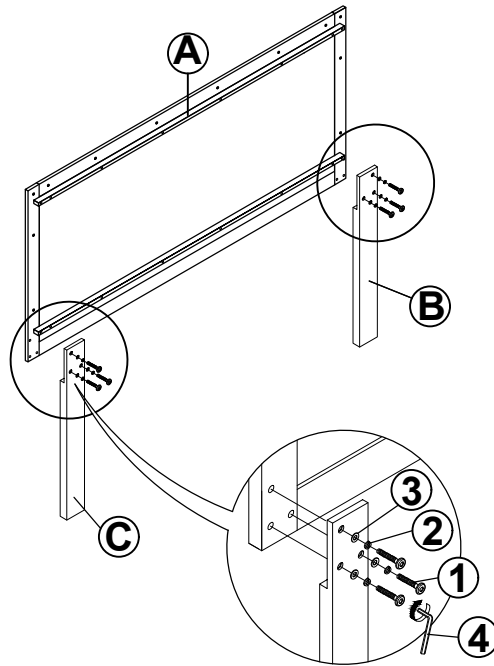

STEP 2

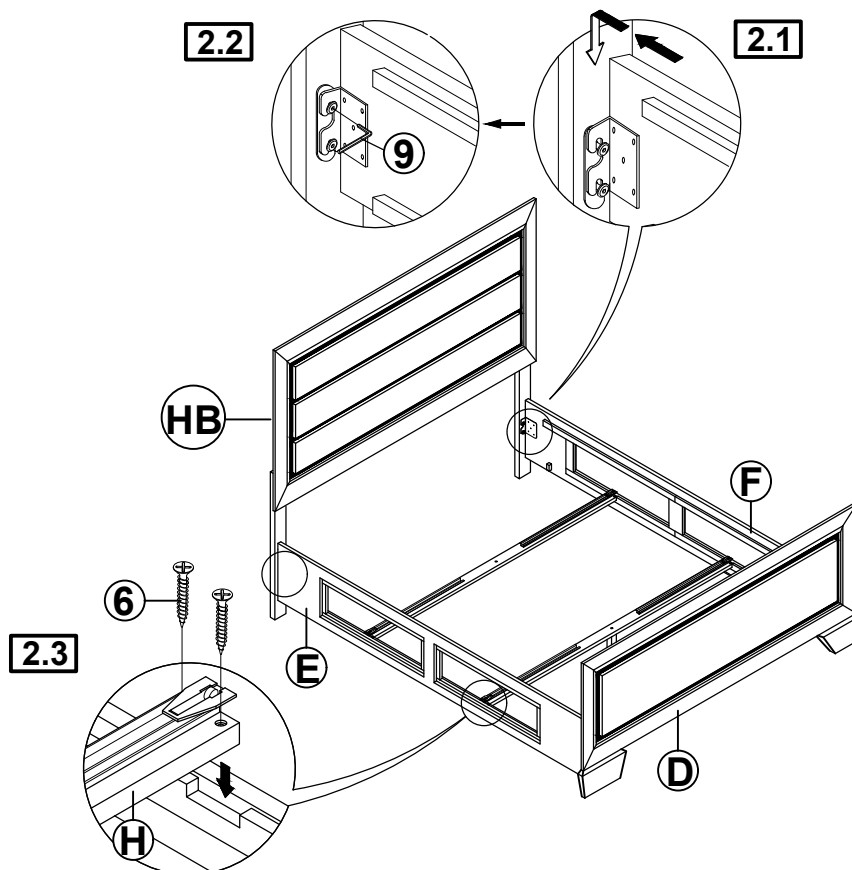

ITEM: 204190Q(B1-B4)

ASSEMBLY INSTRUCTIONS

STEP 3

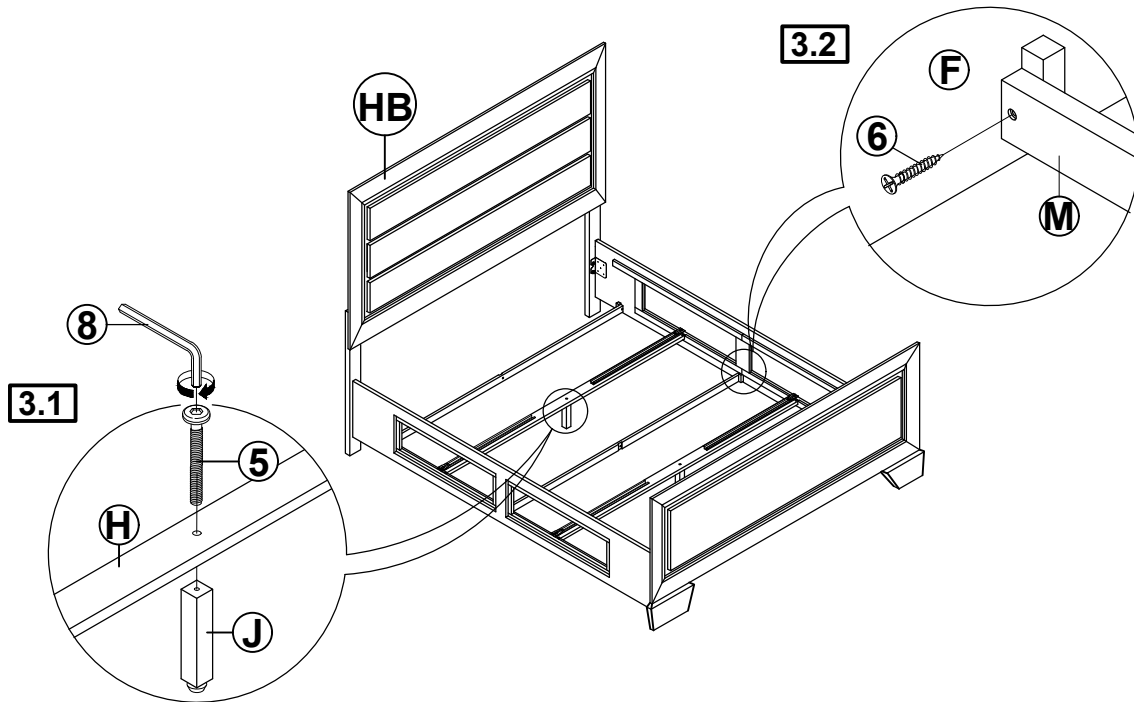

STEP 4

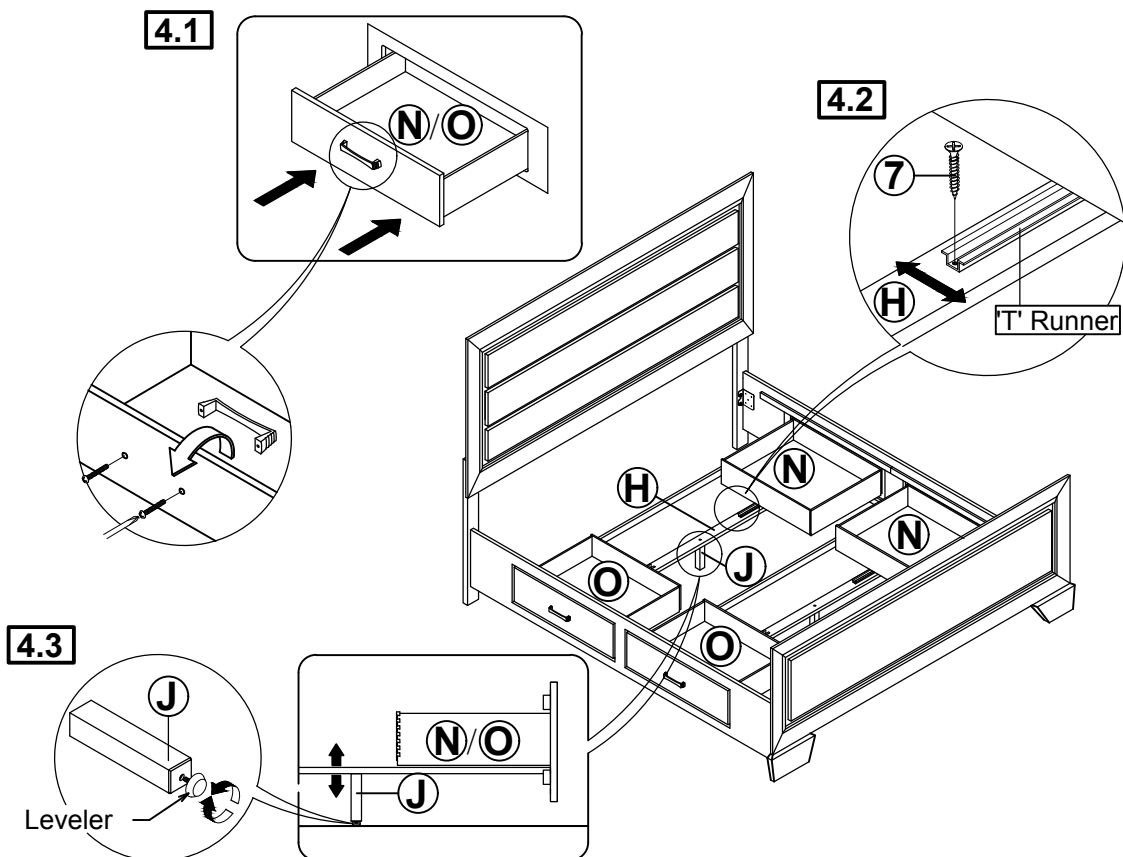

ITEM: 204190Q(B1-B4)

ASSEMBLY INSTRUCTIONS

STEP 5

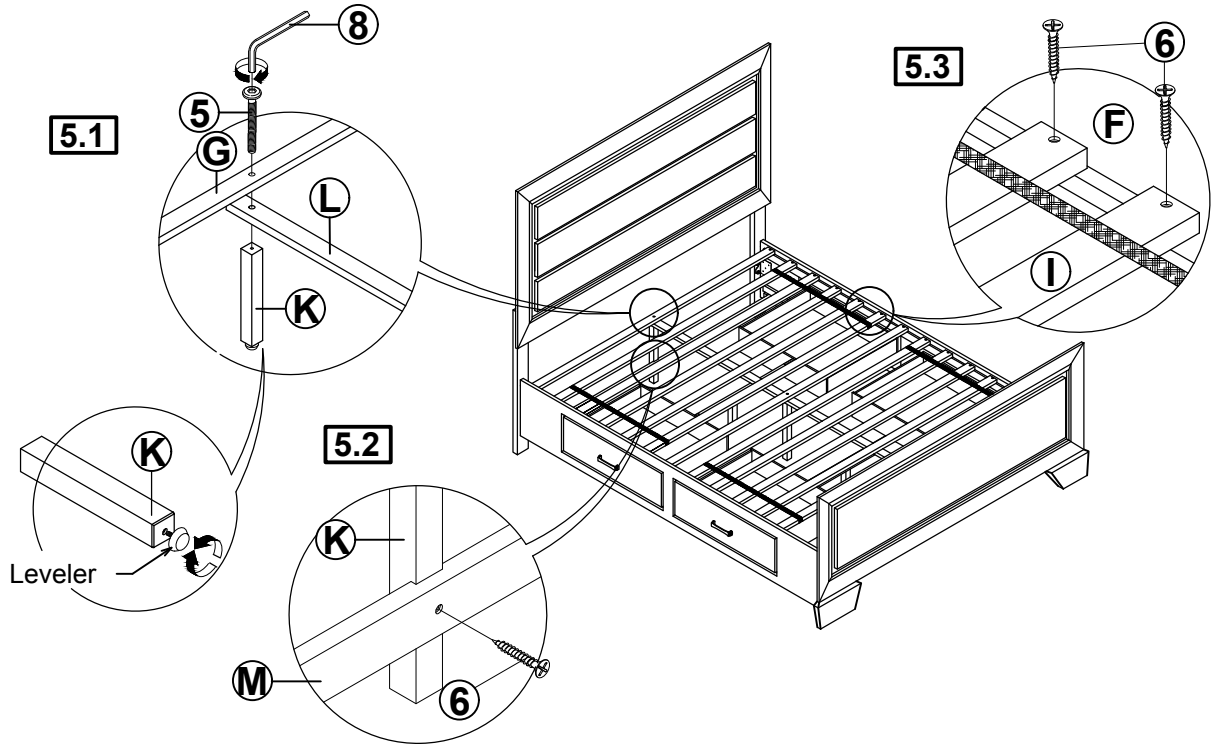

STEP 6

COMPLETE

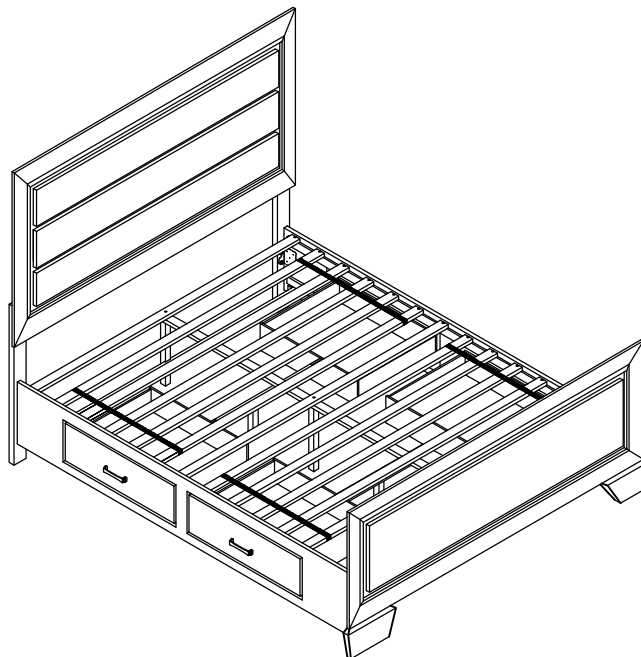

ITEM: **204190Q(B1-B4)**



Inner Size : 61.00"W X 81.75"D

Inner Size of Drawer : 24.00"W X 17.75"D X 5.75"H X 0.25T

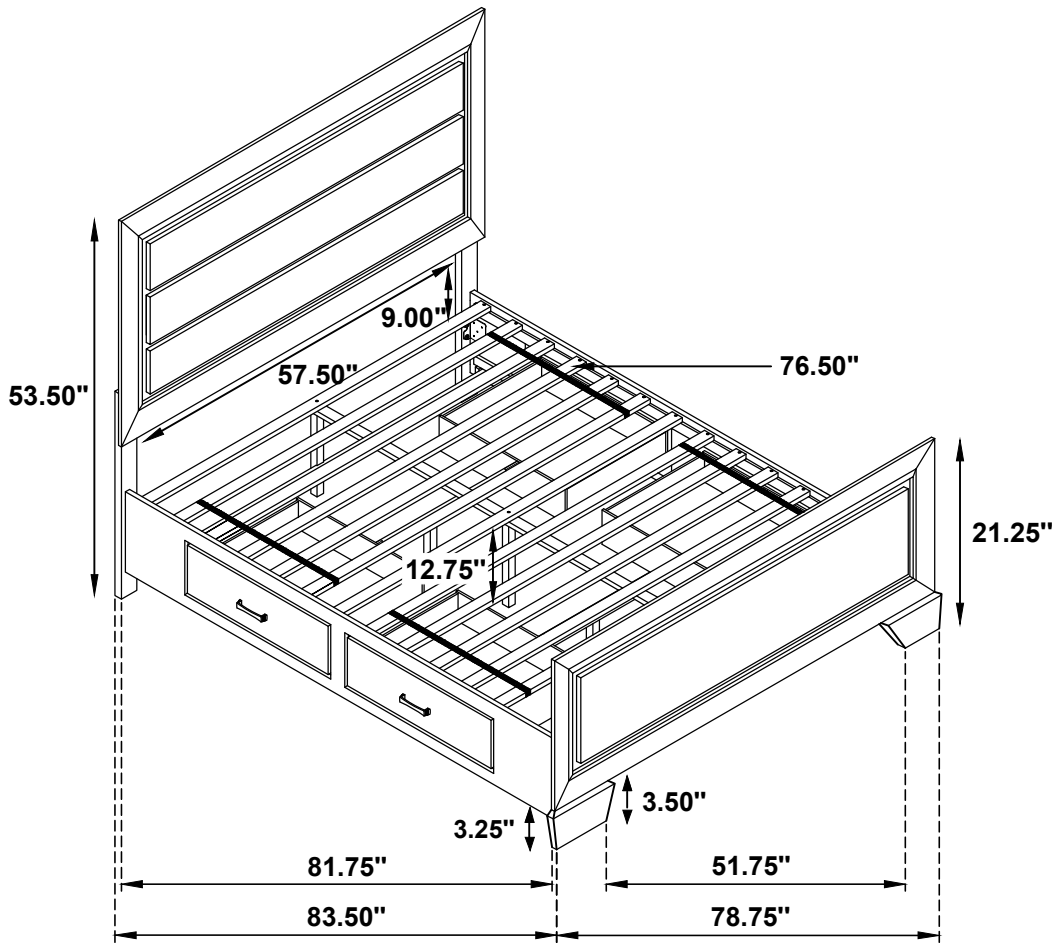

Note : Dimension tolerance $\pm 5\%$