

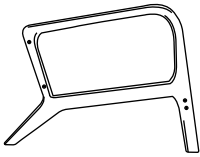

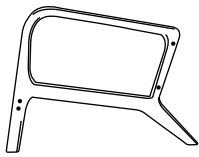



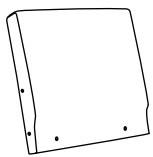

# ASSEMBLY INSTRUCTIONS

Ax1  Right armrest	Bx1  Left armrest	Cx1  Stretcher	Dx1  Backrest	Ex1  Seat pad	Fx1  Pillow
Gx10  Bolt M8*60mm	Hx2  Washer	Ix1  Allen wrench	Jx8  Plastic cover	Kx4  Felt pad	

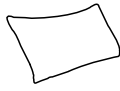

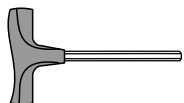
Before assembling, unscrew the bolts and take-down the armrests from the fixing board.

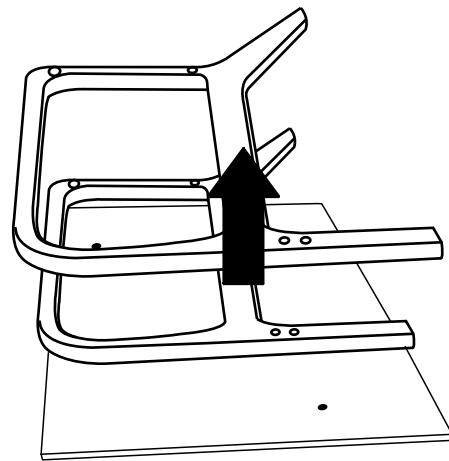
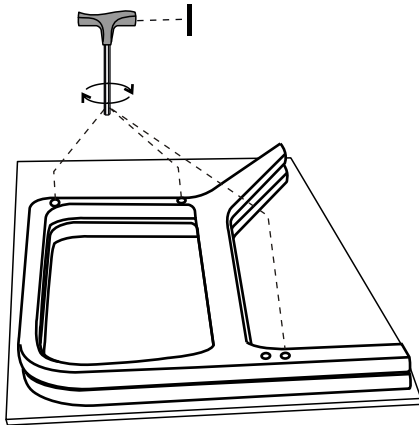
## STEP 1

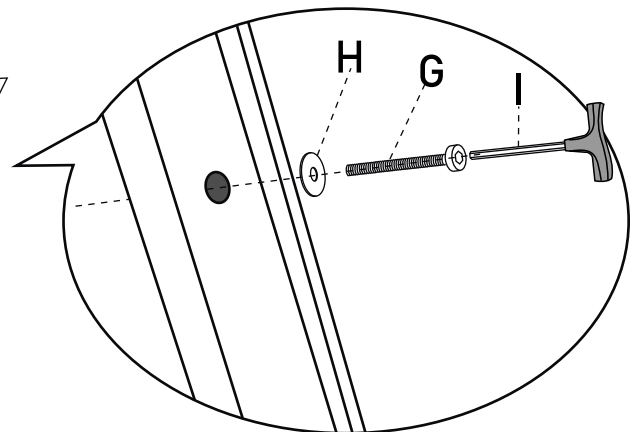
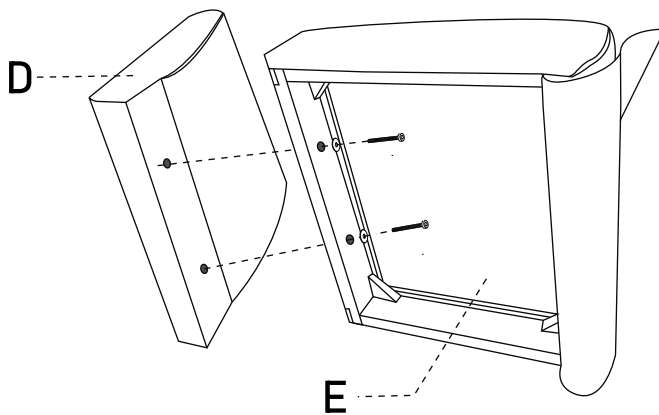

**STEP 2**

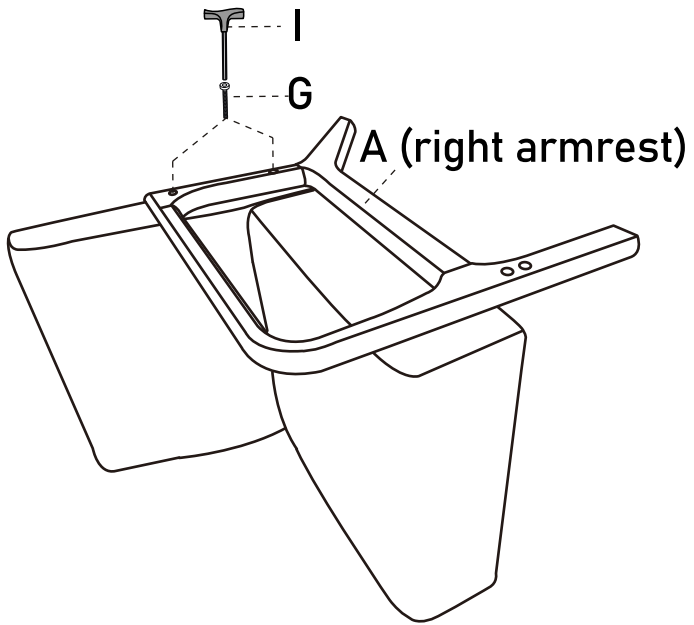

**STEP 3**

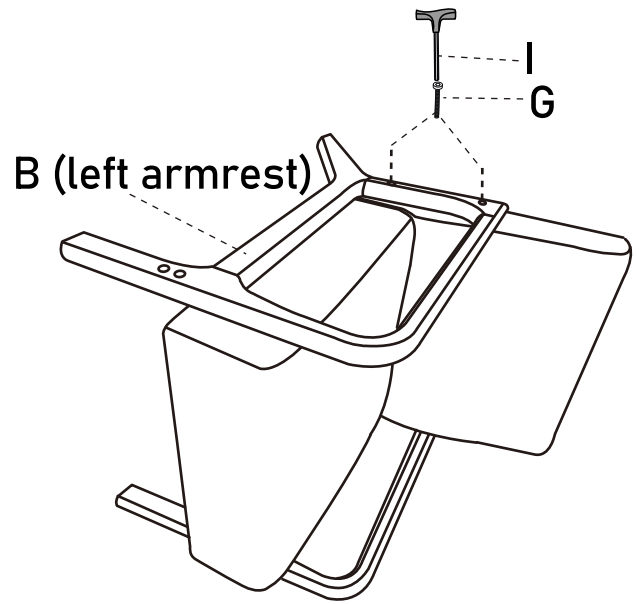

**STEP 4**

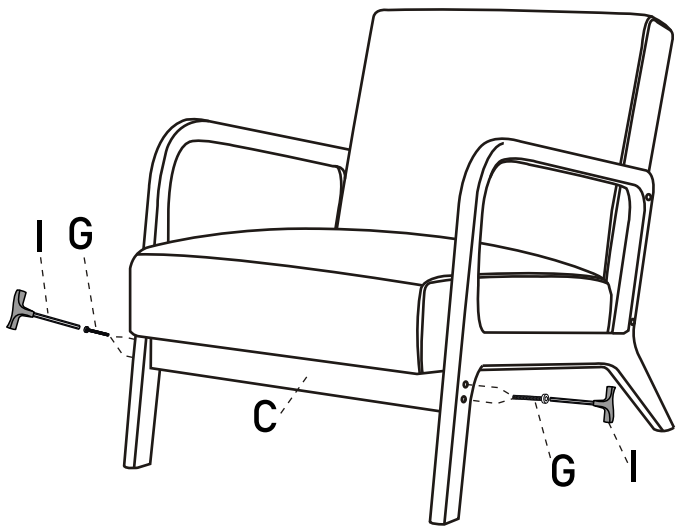

**STEP 5**

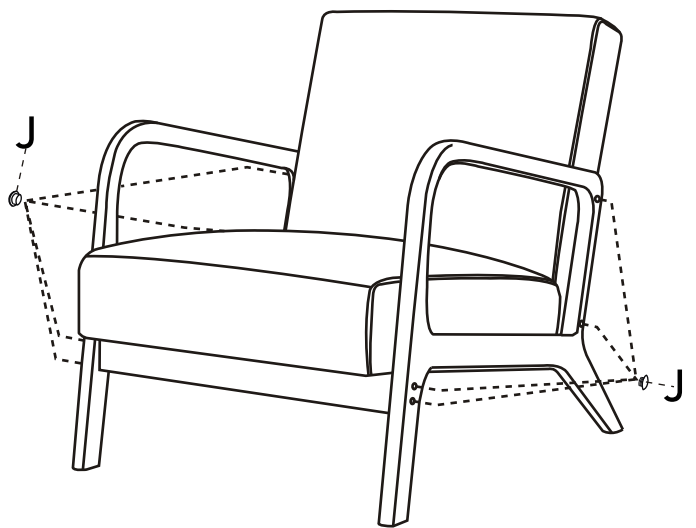

**STEP 6**

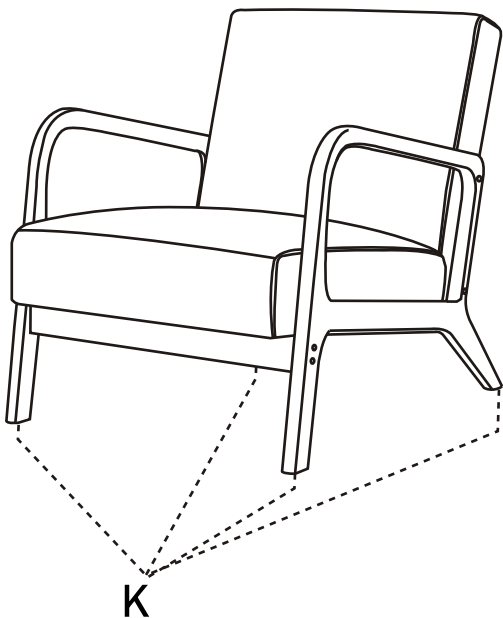

**STEP 7**

