

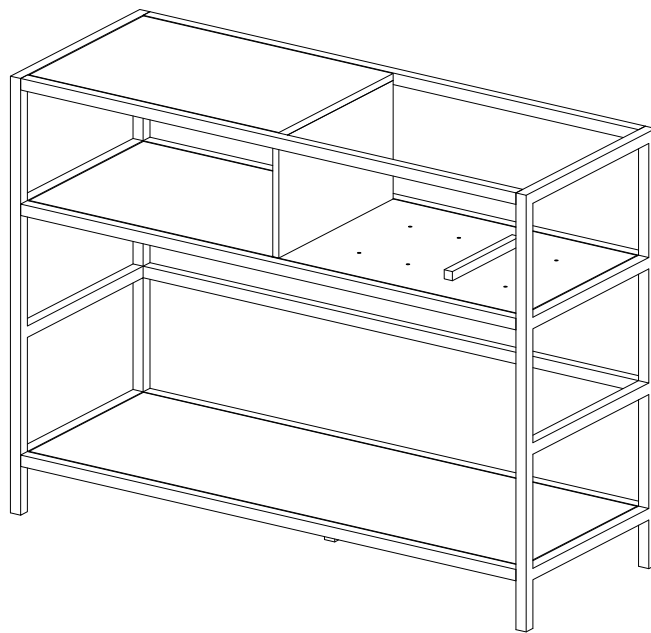

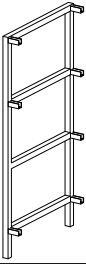

CROSLEY
FURNITURE

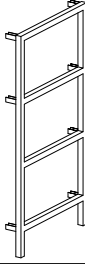

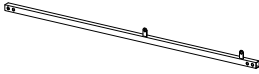
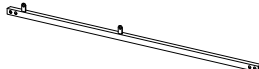

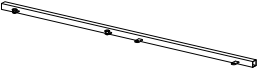
Console Table
CF1143

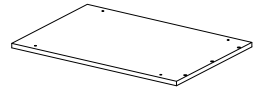
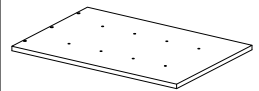
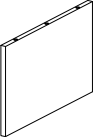
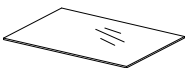
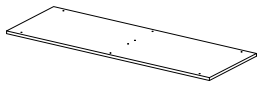
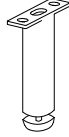
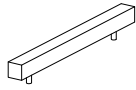

PART LIST

				
<p>Left Panel 1 PC</p>	<p>Right Panel 1 PC</p>	<p>Top Front Bar 1 PC</p>	<p>Top Back Bar 1 PC</p>	<p>Front Shelf Bar 1 PC</p>
				
<p>Back Shelf Bar 1 PC</p>	<p>Cross Bar 1 PC</p>	<p>Bottom Bar 2 PCS</p>	<p>Top Panel 1 PC</p>	<p>Shelf Panel 1 PC</p>
				
<p>Middle Partition Panel 1 PC</p>	<p>Shelf Glass 1 PC</p>	<p>Bottom Panel 1 PC</p>	<p>Support Leg 1 PC</p>	<p>Stopper 1 PC</p>

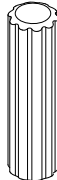
HARDWARE LIST

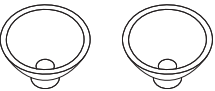
 <p>1/4" x 1/2"L</p>	 <p>1/4" x 3/8"L</p>			
<p>Bolt 28 PCS (Extra 1)</p>	<p>Short Bolt 16 PCS (Extra 1)</p>	<p>Allen Wrench 1 PC</p>	<p>Wood Dowel 6 PCS (Extra 1)</p>	<p>Safety Strap Kit 1 SET</p>
 <p>Suction Cup Extra 2 PCS</p>				

Step 1. Lay left panel (part A) upside down on a soft flat surface, such as carpet, as shown below. Insert top front bar (part C), top back bar (part D), front shelf bar (part E), back shelf bar (part F), cross bar (part G) and bottom bars (part H) to left panel (part A) using bolts (part #1) and allen wrench (part #3).

Note: Please do not fully tighten bolts at this time.

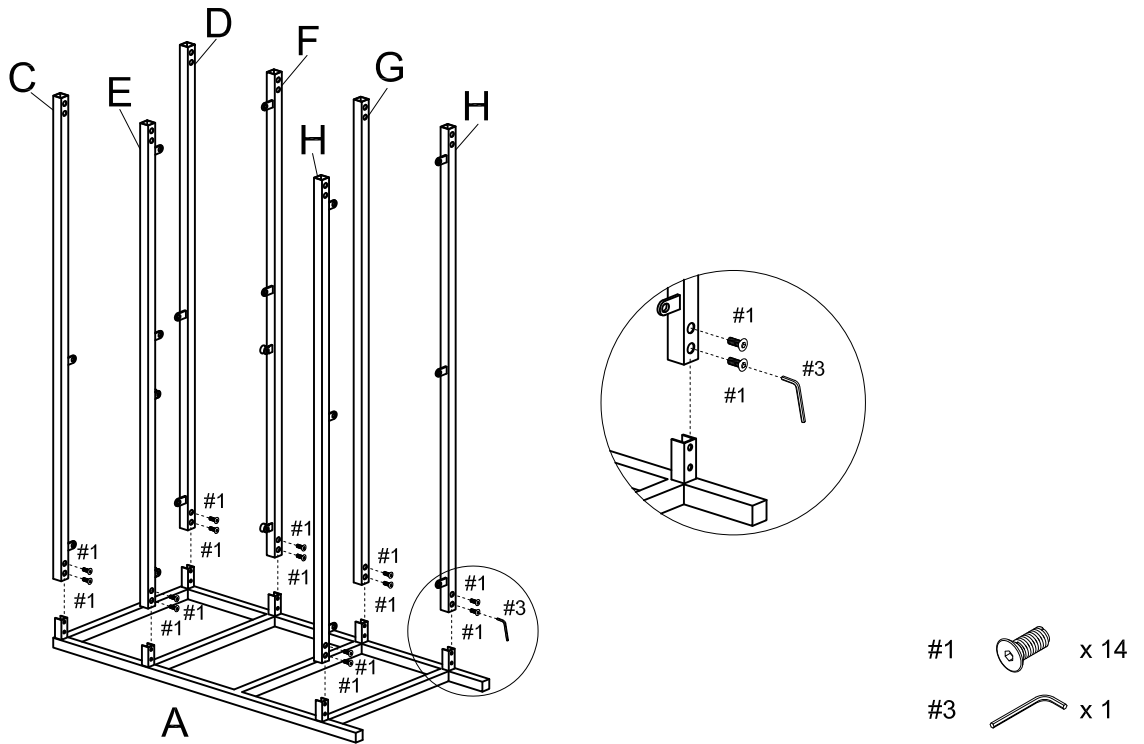

Step 2. Attach right panel (part B) to assembled unit (parts A, C, D, E, F, G & H) using bolts (part #1) and allen wrench (part #3).

Note: Please do not fully tighten bolts at this time.

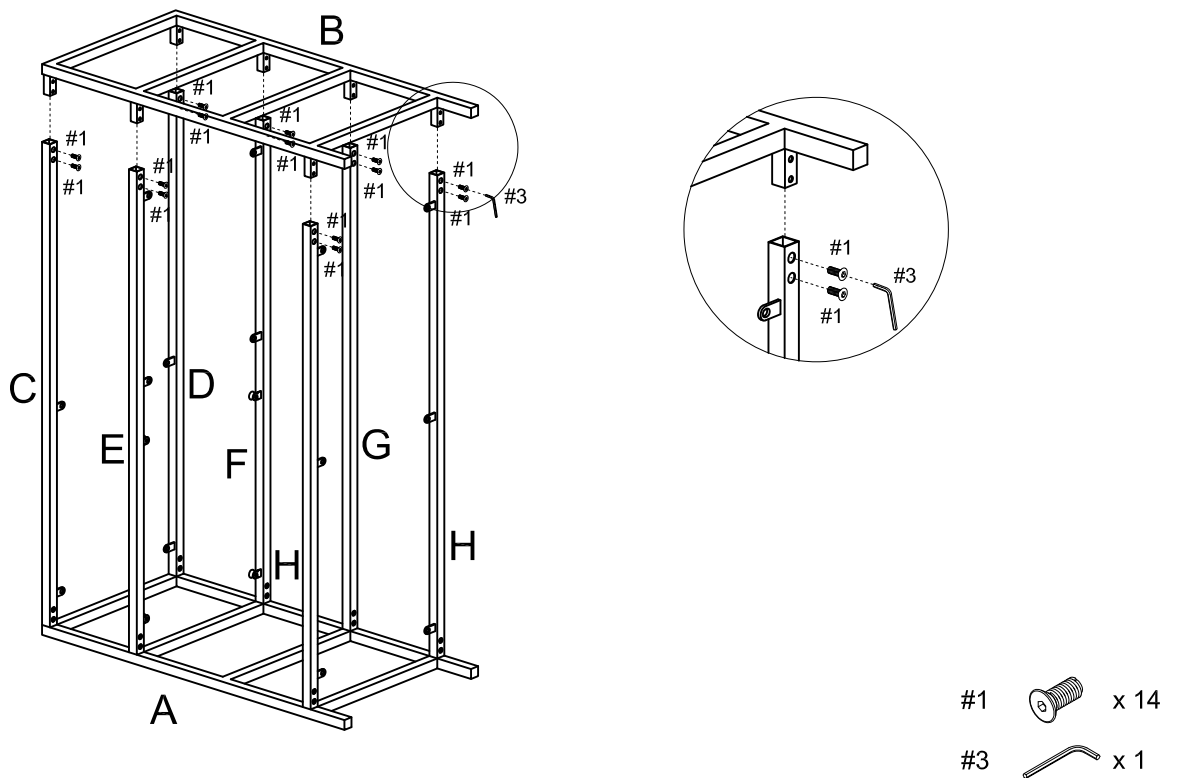

Step 3. Attach shelf panel (part J) and bottom panel (part M) to shelf bars (parts E & F) and bottom bars (part H) using short bolts (part #2) and allen wrench (part #3). Attach support leg (part N) to bottom panel (part M) using short bolts (part #2) and allen wrench (part #3).

Note: Please do not fully tighten bolts at this time.

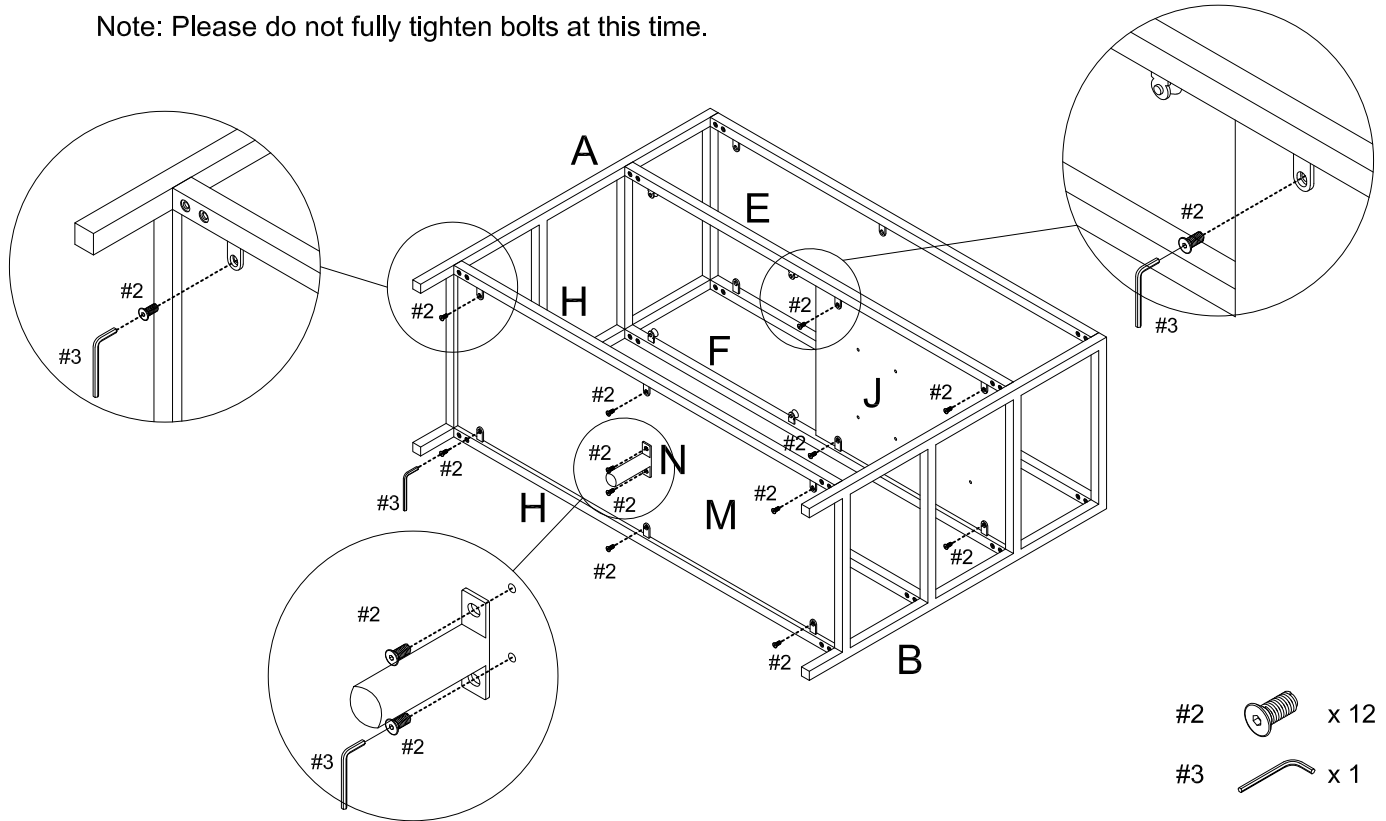

Step 4. Carefully turn unit upright. Insert wood dowels (part #4) into middle partition panel (part K). Attach middle partition panel (part K) to shelf panel (part J). Attach top panel (part I) to top front bar (part C), top back bar (part D) and middle partition panel (part K) using short bolts (part #2) and allen wrench (part 3).

Note: Please fully tighten bolts at this time.

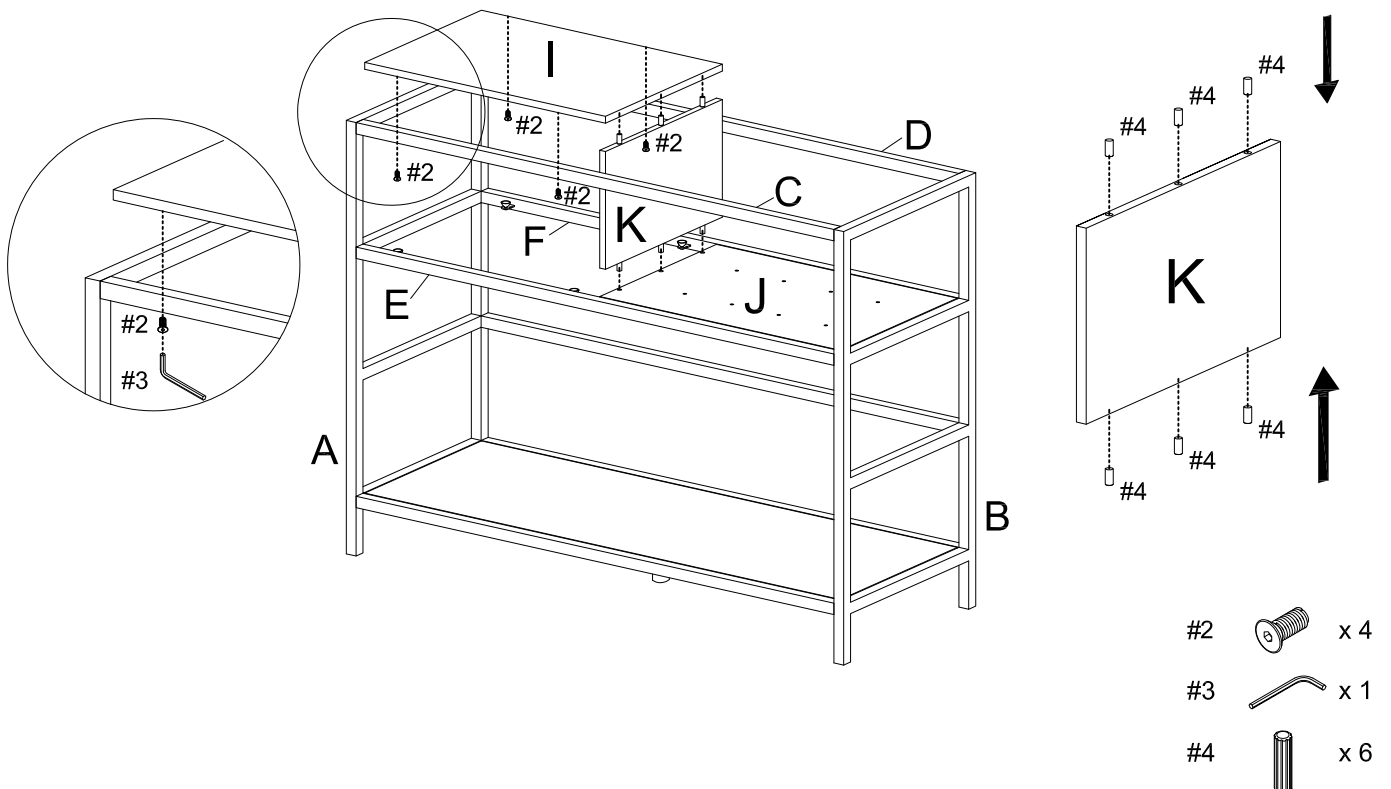



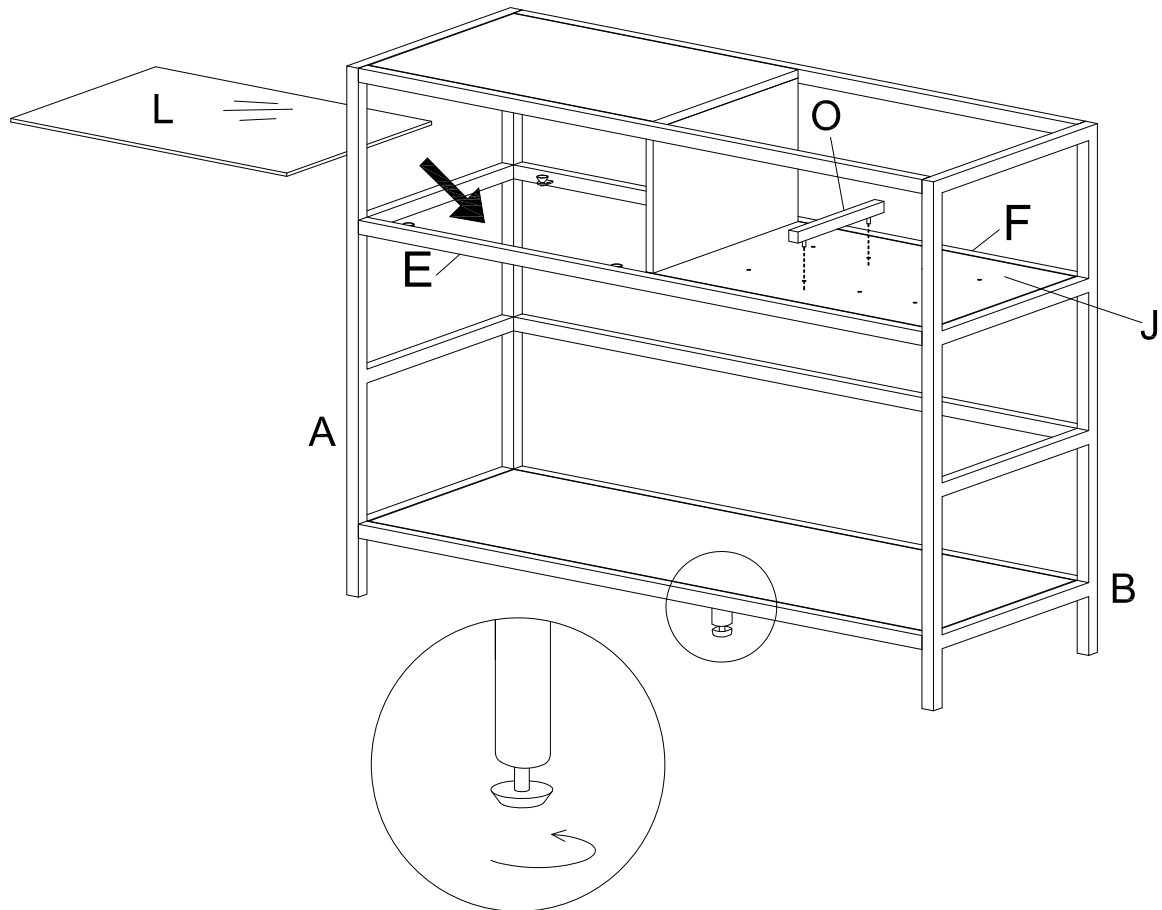

Step 5. Insert shelf glass (part L) and stopper (part O) to assembled unit.

Note: Safety strap kit (part #5) must be installed to prevent tipping, damage and/ or injury.

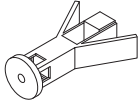
Note: It is important to adjust leveler once fully assembled and upright. Extend adjustable leveler until it's firmly in contact with the floor. If relocating, adjust leveler as needed until it's firmly in contact with floor in new location.



#5	A	B	C	D	E
					
Safety Strap Kit 1 SET	Wall Anchor 1 PC	Hook 2 PCS	D8 x 1-1/2" Screw 1 PC	D10 x 1/2" Bolt 1 PC	Safety Wall Strap 1 PC

SAFETY WALL STRAP INSTALLATION

Important: Safety strap kit (part #5) must be installed to prevent tipping, damage and / or injury.

1) Insert bolt (D) through hook (B) and attach to predrilled hole in top back bar (part D) using a philips head screwdriver.

2) Drill 11/32" hole in the wall where this unit will be secured. The drilled hole will be at the same height as the hole in top back bar (part D) where hook (B) was attached. Tap wall anchor (A) into the drilled hole.

3) Insert screw (C) through hook (B) into the wall anchor (A) using a philips head screwdriver.

4) Insert safety wall strap (E) through both hooks (B) and tighten to secure.

Note: This item is not intended for clothing storage use.

