



INSTALLATION GUIDE

ST-05
STANDARD STRAINER

WATCH OUR VIDEO ON **YOUTUBE**

WARRANTY



Installation of Stylish® Sink Standard Strainer

For additional technical assistance or for any questions or concerns about your kitchen strainer's warranty, please contact us.

www.stylishkb.com

care@stylishkb.com

www.stylishkb.com/warranty

+1-855-789-5352

IF YOU HAVE PURCHASED A **STANDARD STRAINER**, PLEASE MAKE SURE TO READ THESE INSTRUCTIONS CAREFULLY

1

Strainer body
Sink
Foam

Place foam gasket and strainer body on the top side of drain opening. Alternatively Plumber's Putty could be used instead of foam gasket.

2

Rubber gasket
Outer gasket
Basket nut

From underneath bring outer basket with rubber gasket under the sink and secure with basket nut.

3

Tighten basket nut using channel locks or wrench.

4

Tail pipe
Tail pipe nut

Insert tail pipe with nut into home's plumbing, then align and secure tail pipe nut to strainer body.

5

Rubber gasket

Tighten tail pipe nut to strainer body, ensure the rubber gasket is present.

6

Basket

Run water and confirm no leaks.

CARE AND CLEANING

1. Rinse the strainer with water.
2. Coat the strainer with baking soda, Flitz or Barkeepers friend.
3. With sponge, scrub strainer and all sink walls in the direction of the steel grain.
4. Spray on undiluted vinegar.
5. Rinse again.
6. Buff with a few drops of olive oil.
7. If necessary, repeat procedure.

Stylish International Inc.

Follow us on Instagram! Check out and let us know your comments [stylish.international.inc](https://www.instagram.com/stylish.international.inc)

REGARDEZ NOTRE VIDÉO SUR **YOUTUBE**

GARANTIE



Installation de la Crépine Standard d'évier de Stylish®

Pour obtenir une assistance technique supplémentaire ou pour toute question concernant la garantie de votre filtre de cuisine, veuillez nous contacter.

 www.stylishkb.com

 care@stylishkb.com

www.stylishkb.com/warranty

 +1-855-789-5352

SI VOUS AVEZ ACHETÉ UNE **CRÉPINE STANDARD**, VEUILLEZ LIRE ATTENTIVEMENT CES INSTRUCTIONS.

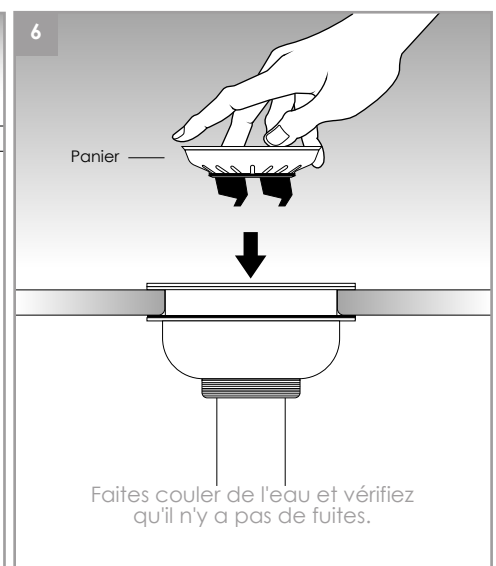
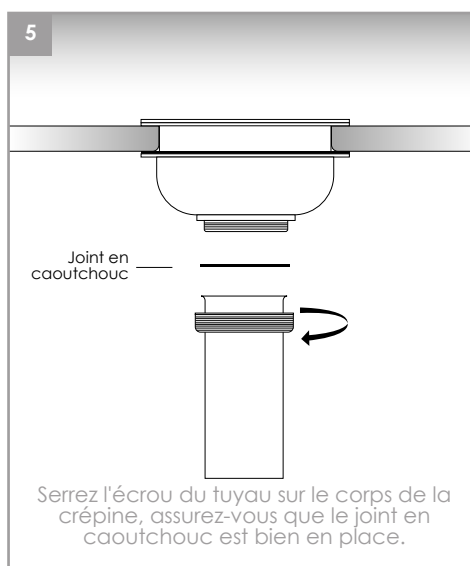
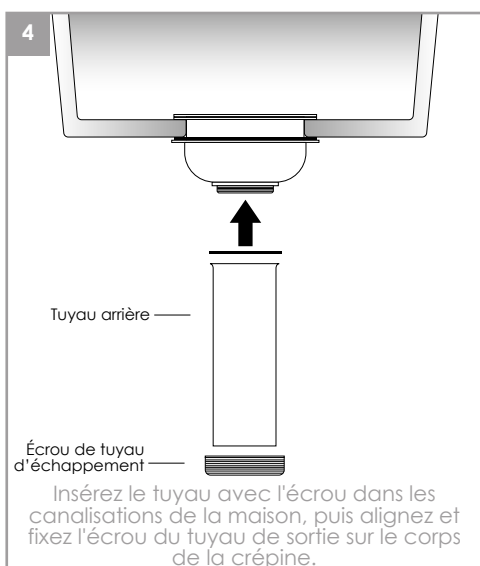
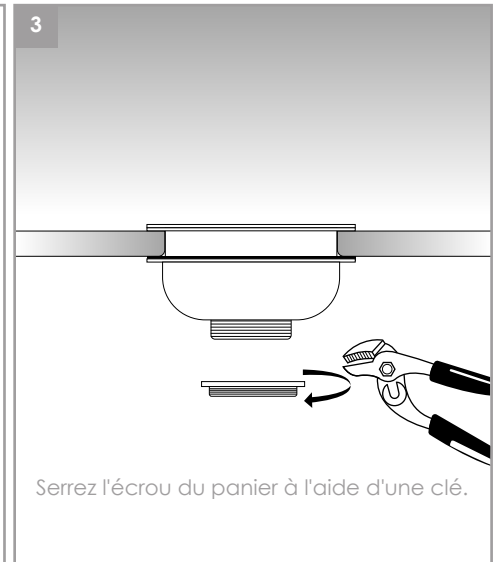
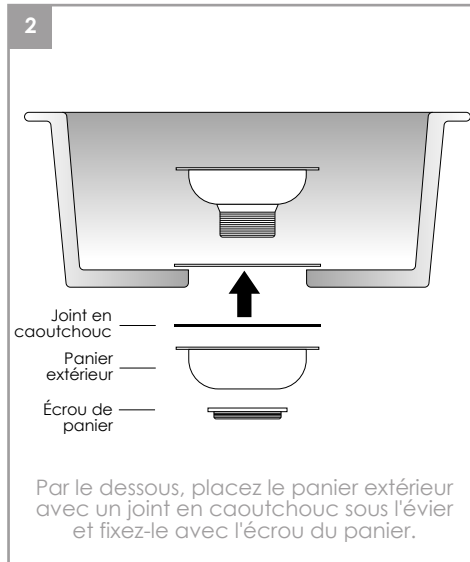
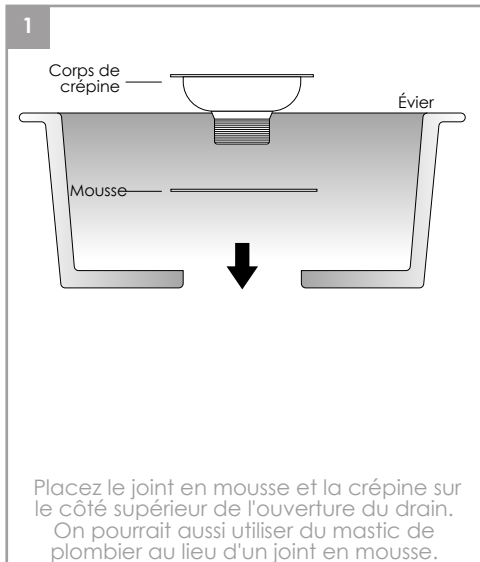

ENTRETIEN ET NETTOYAGE

- Rincez la crépine à l'eau.
- Versez du bicarbonate de soude, du Flitz ou du Barkeepers friend dans la passoire.
- Avec une éponge, frottez la crépine et toutes les parois de l'évier dans le sens du grain d'acier.
- Vaporisez du vinaigre non dilué.
- Rincez à nouveau.
- Frottez avec quelques gouttes d'huile d'olive.
- Si nécessaire, répétez la procédure.

Stylish International Inc. Suivez-nous sur Instagram! Jetez un coup d'œil et faites-nous part de vos commentaires  [stylish.international.inc](https://www.instagram.com/stylish.international.inc)