

ASSEMBLY INSTRUCTIONS
COASTER FINE FURNITURE

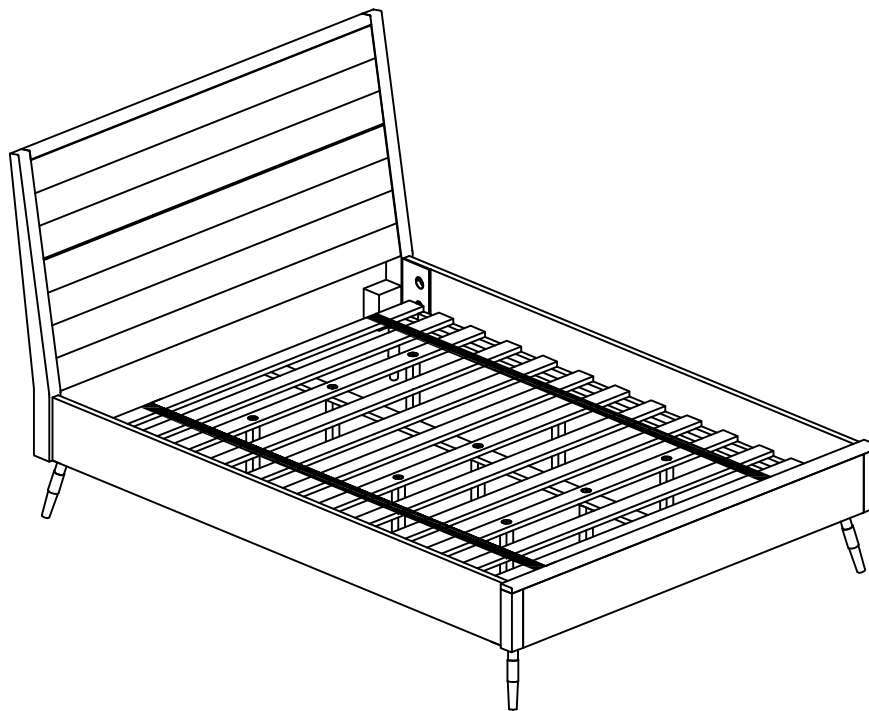

Fine Furniture for every stage of life

215761KE (B1-B3)
Eastern King Bed

ITEM: 215761KE (B1-B3)



ASSEMBLY INSTRUCTIONS

ASSEMBLY TIPS:

1. Remove hardware from box and sort by size.
2. Please check to see that all hardware and parts are present prior to start of assembly.
3. Please follow attached instructions in the same sequence as numbered to assure fast & easy assembly.



WARNING!

1. Don't attempt to repair or modify parts that are broken or defective. Please contact the store immediately.
2. This product is for home use only and not intended for commercial establishments.



ASSEMBLY

20 MINUTES

PARTS IDENTIFICATION

B1 (BOX 1)



B2 (BOX 2)



B3 (BOX 3)

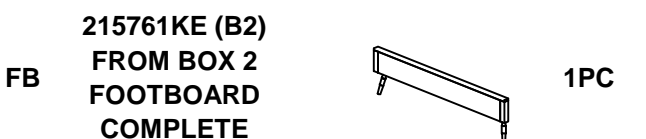
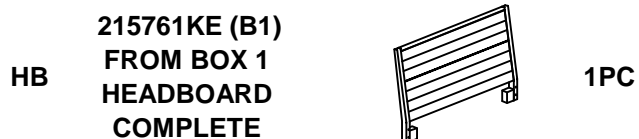
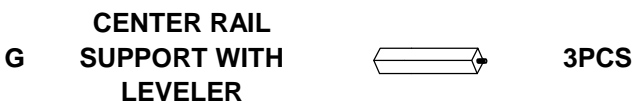
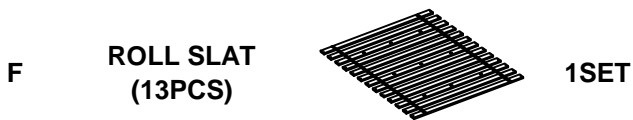
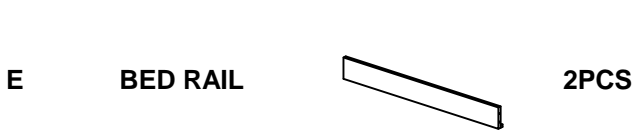

ITEM: 215761KE (B1-B3)



ASSEMBLY INSTRUCTIONS

ASSEMBLY TIPS:

1. Remove hardware from box and sort by size.
2. Please check to see that all hardware and parts are present prior to start of assembly.
3. Please follow attached instructions in the same sequence as numbered to assure fast & easy assembly.







WARNING!





1. Don't attempt to repair or modify parts that are broken or defective. Please contact the store immediately.
2. This product is for home use only and not intended for commercial establishments.

HARDWARE IDENTIFICATION





Z-B1 (BOX 1) - HARDWARE PACK IS LOCATED IN 215761KE (B1)

1	BOLT (Ø5/16" x 25mm - RBW)		6PCS	3	FLAT WASHER (Ø5/16" x 19 x 2mm - RBW)		6PCS
2	LOCK WASHER (Ø5/16" x 14 x 2mm - RBW)		6PCS	4	ALLEN WRENCH (M4 x 58mm - RBW)		1PC

Z-B2 (BOX 2) - HARDWARE PACK IS LOCATED IN 215761KE (B2)

5	BOLT (Ø5/16" x 25mm - RBW)		6PCS	7	FLAT WASHER (Ø5/16" x 19 x 2mm - RBW)		6PCS
6	LOCK WASHER (Ø5/16" x 14 x 2mm - RBW)		6PCS	8	ALLEN WRENCH (M4 x 58mm - RBW)		1PC

Z-B3 (BOX 3) - HARDWARE PACK IS LOCATED IN 215761KE (B3)

9	THREADED BOLT (Ø5/16" x 80mm - RBW)		8PCS	12	WRENCH (M12 x 90mm - RBW)		1PC
10	U-SQUARE WASHER (Ø5/16" x 35 x 14mm - RBW)		8PCS	13	PAN HEAD SCREW (Ø8 x 30mm - RBW)		10PCS
11	HEX NUT (Ø5/16" x 12 x 18mm - RBW)		8PCS				

NOTE:

Phillips head screw driver is required in the assembly process; however, manufacturer does not provide this item.

ITEM: 215761KE (B1-B3)



ASSEMBLY INSTRUCTIONS

STEP 1

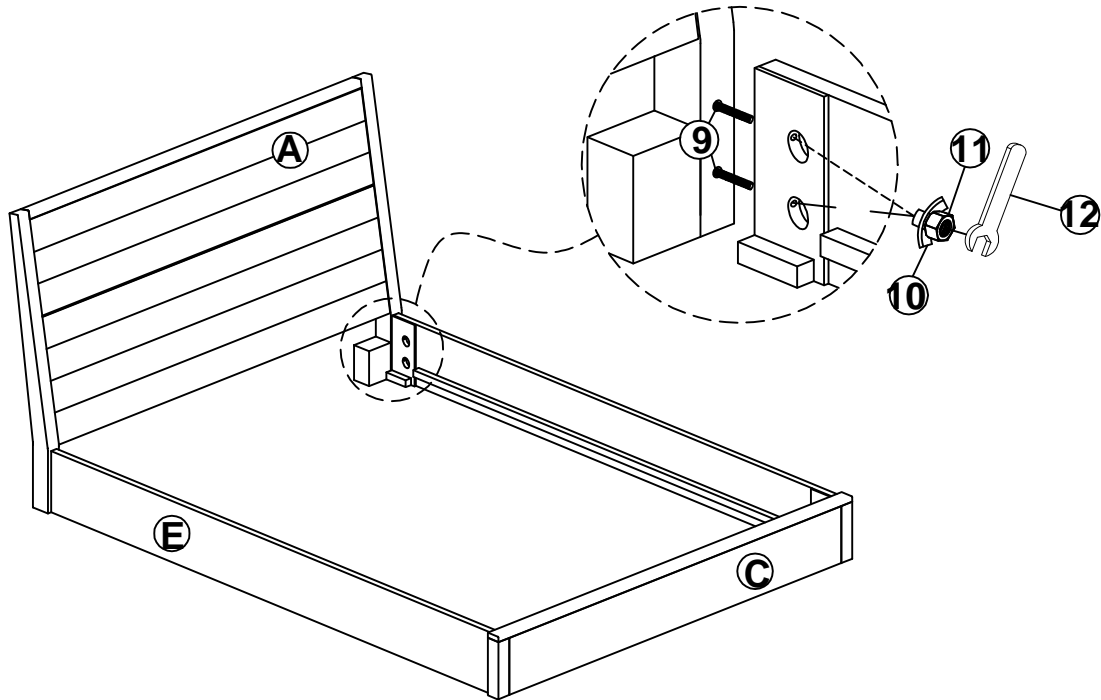

STEP 2

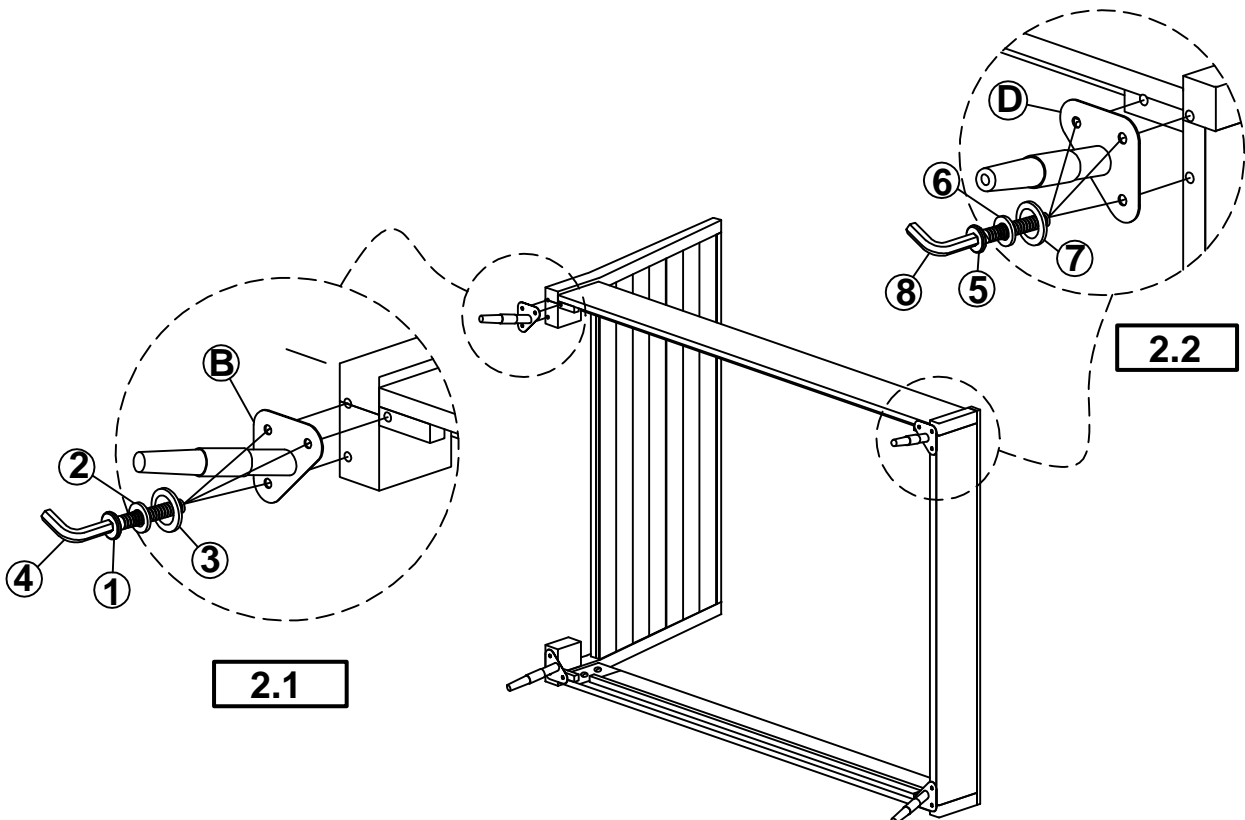

ITEM: **215761KE (B1-B3)**



ASSEMBLY INSTRUCTIONS

STEP 3

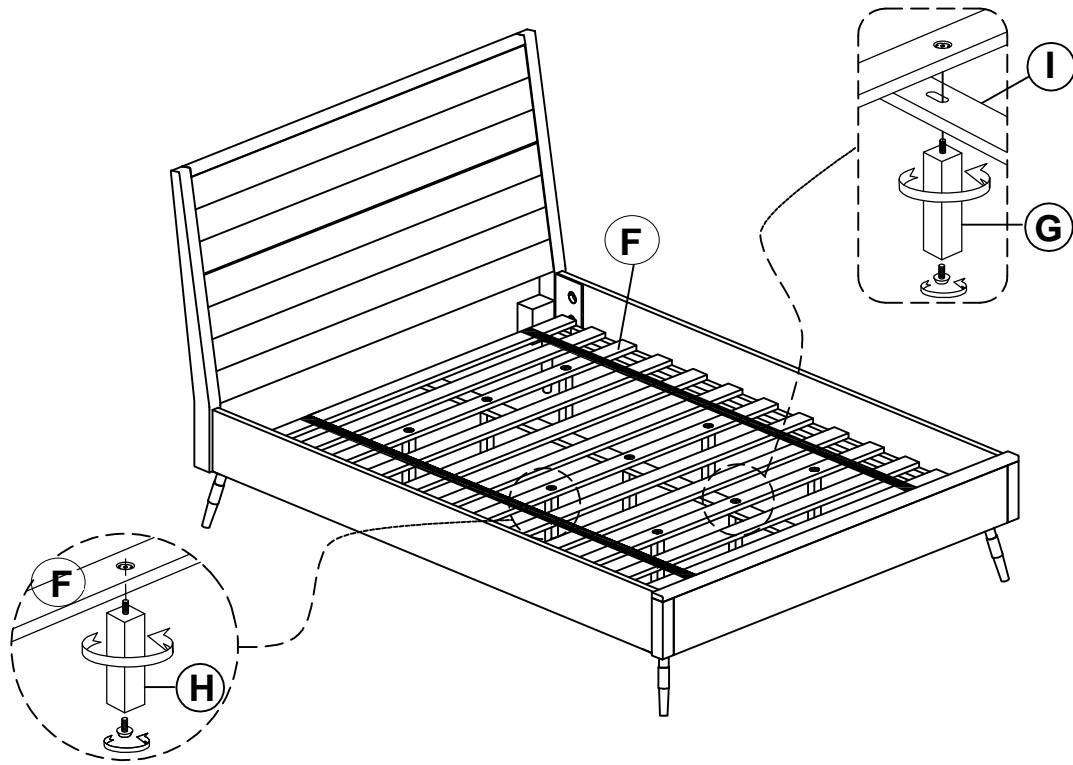

STEP 4
COMPLETE

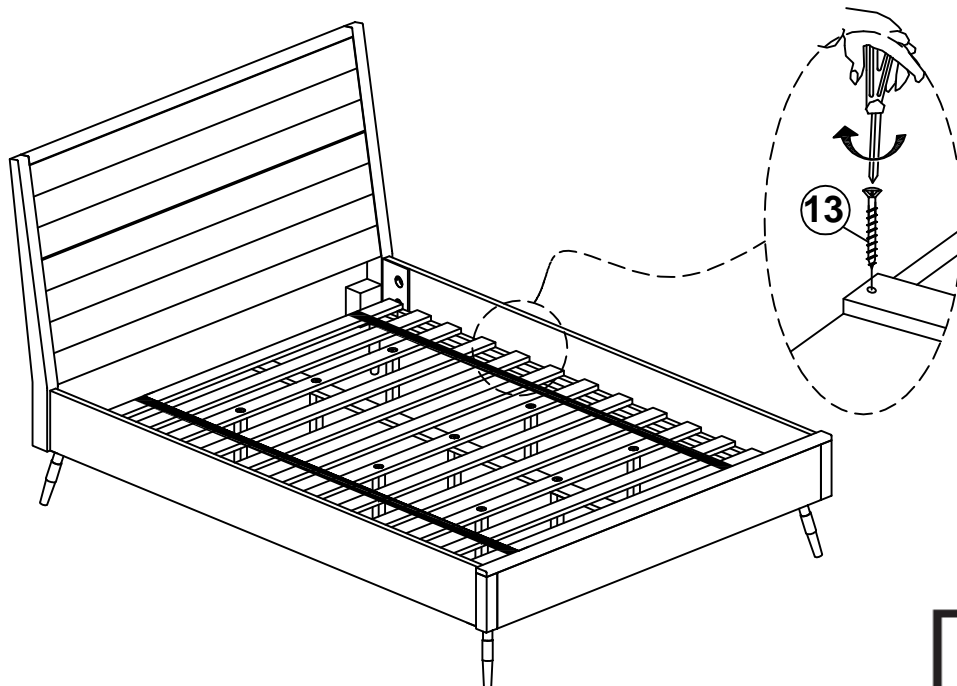

ITEM: 215761KE (B1-B3)



Inner Size : 77.25"W x 81.00"D

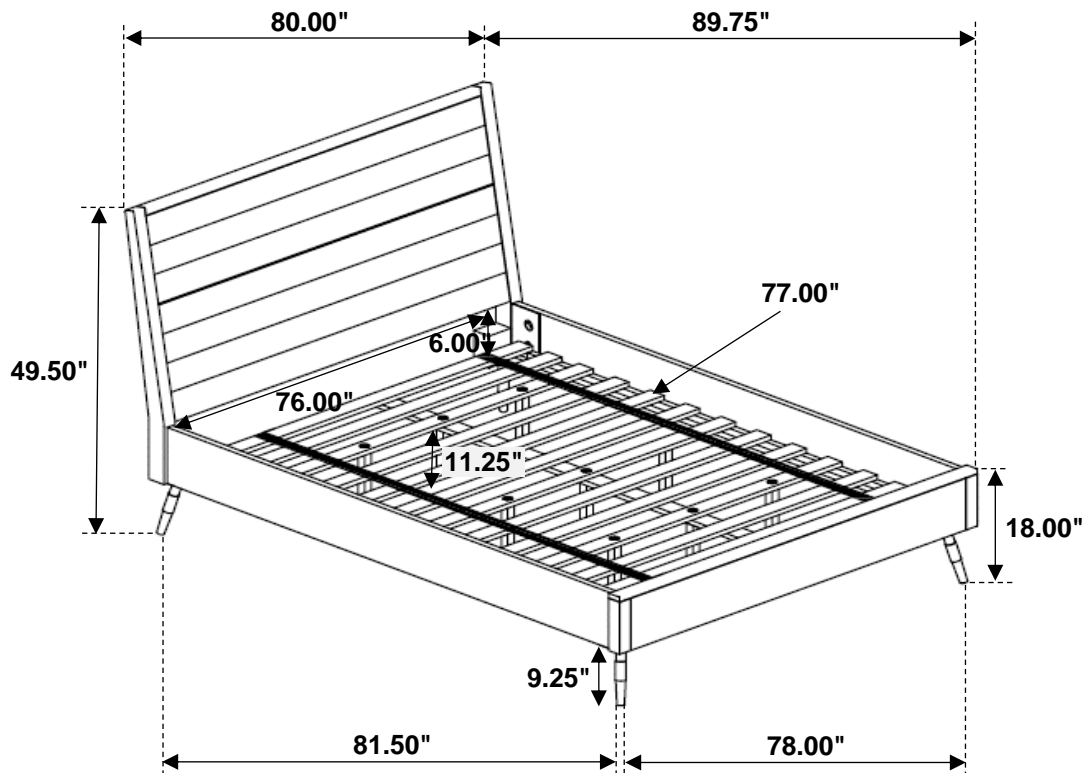

Note: Dimension tolerance $\pm 5\%$