











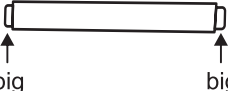
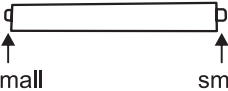
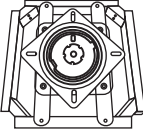

ASSEMBLY INSTRUCTION

24" SWIVEL COUNTER HEIGHT CHAIR WITH SQUARE SEAT

| | | | | |
|--|--|--|--|---|
| A Backrest  1 PC | B Cushion Seat  1 PC | C Stretcher (Front & Back)  2 PCS | D Stretcher (Left & Right)  2 PCS | E Apron with Swivel Plate  1 PC |
| F Chair Leg (No Hole)  2 PCS | G Chair Leg (Hole)  2 PCS | H CBS Screw M4 x 38mm  8 PCS | I JCBC Screw M6 x 25mm  4 PCS | J JCBC Screw M6 x 40mm  10 PCS |
| K JCBC Screw M6 x 70mm  4 PCS | L Flat Washer M6.5 x 16.5mm  18 PCS | M Spring Washer M6 x 13mm  14 PCS | N Allen Key M4  1 PC | |



This page lists all the contents included in the box. Please take the time to identify the hardware as well as the individual components to this product. As you unpack and prepare for assembly, place the contents on a carpeted or padded area to protect them from damage.

1

Attached the 2 Pcs Chair Leg (Hole) (G) oppositely to the Apron with Swivel Plate (E), Use JCBC Screw (J), Spring Washer (M), Flat Washer (L) with Allen Key (N).

Do not fully tighten the screws at this step. Fully tighten the screws after step 3 and 4. While assemble, must facing toward arrow.

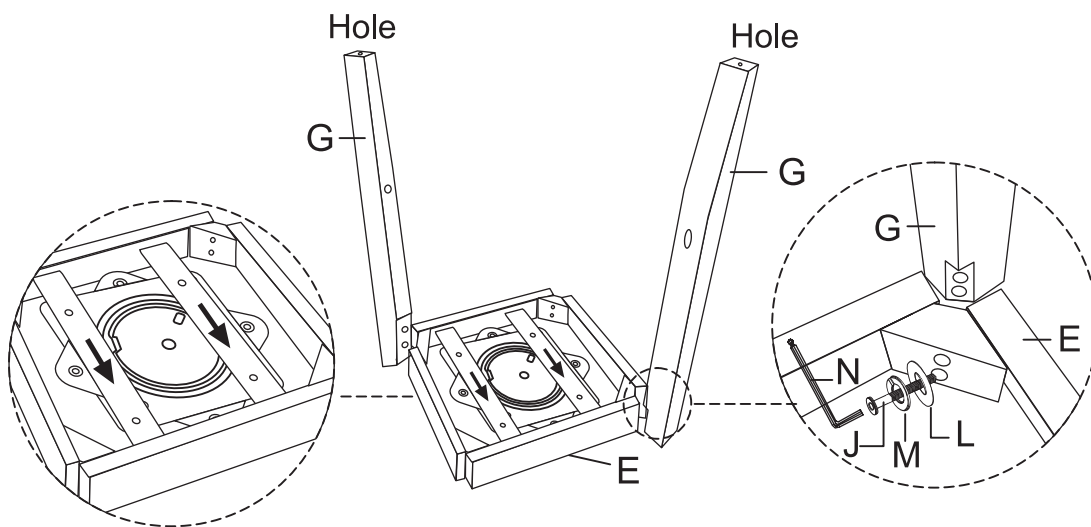

FACING FRONT TOWARD ARROW

Take the Allen Key, and turn the screw until the legs are secure.

DO NOT TIGHTEN COMPLETELY.

Stop when you feel you are adding force to tighten the screw.

2

Attached the 2 Pcs Chair Leg (No Hole) (F) to the Apron with Swivel Plate (E), Use JCBC Screw (J), Spring Washer (M), Flat Washer (L) with Allen Key (N).

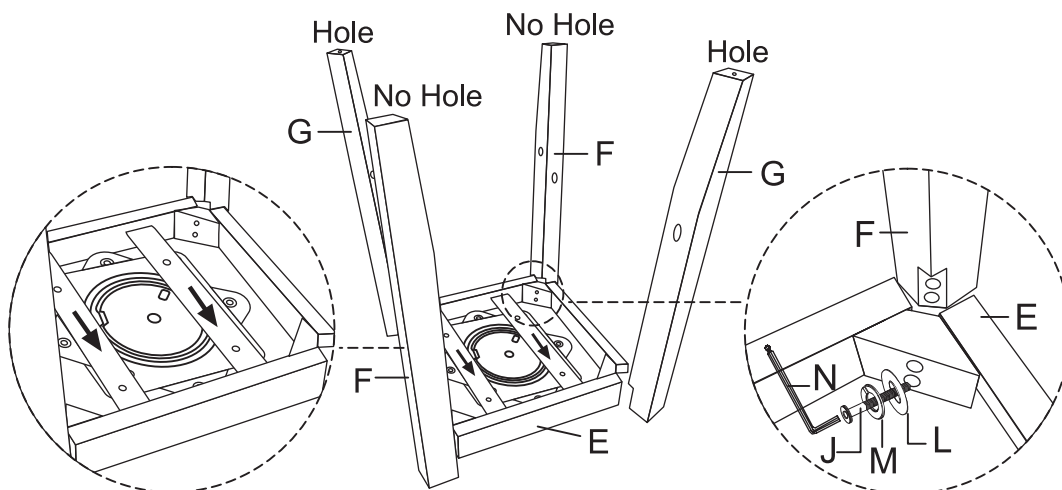

FACING FRONT TOWARD ARROW

3

Then attach the Stretcher (Front & Back) (C) to the big hole on the Chair Leg (F) & (G) with CBS Screw (H).

At Step 3 and 4, align mounting position of the stretcher (C) & (D) to the Chair Leg (F) & (G). At this moment, **DO NOT** use the CBS Screw (H) to tighten first. You only can **FULLY TIGHTEN AFTER YOU HAVE FULLY TIGHTEN THE SCREWS AT STEP 1 AND 2.**

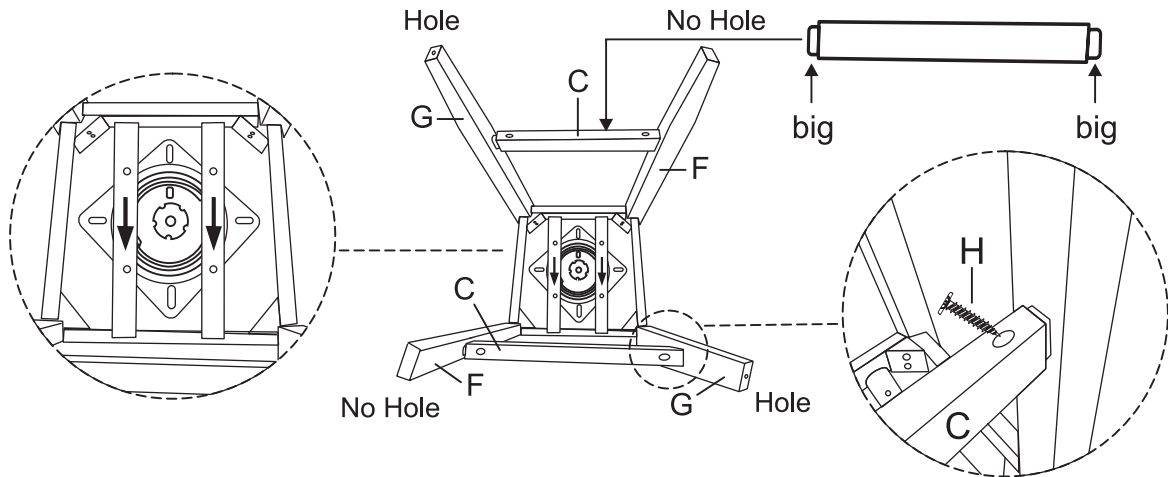

FACING FRONT TOWARD ARROW

4

Then attach the Stretcher (Left & Right) (D) to the small hole on the Chair Leg (F) & (G) with CBS Screw (H).

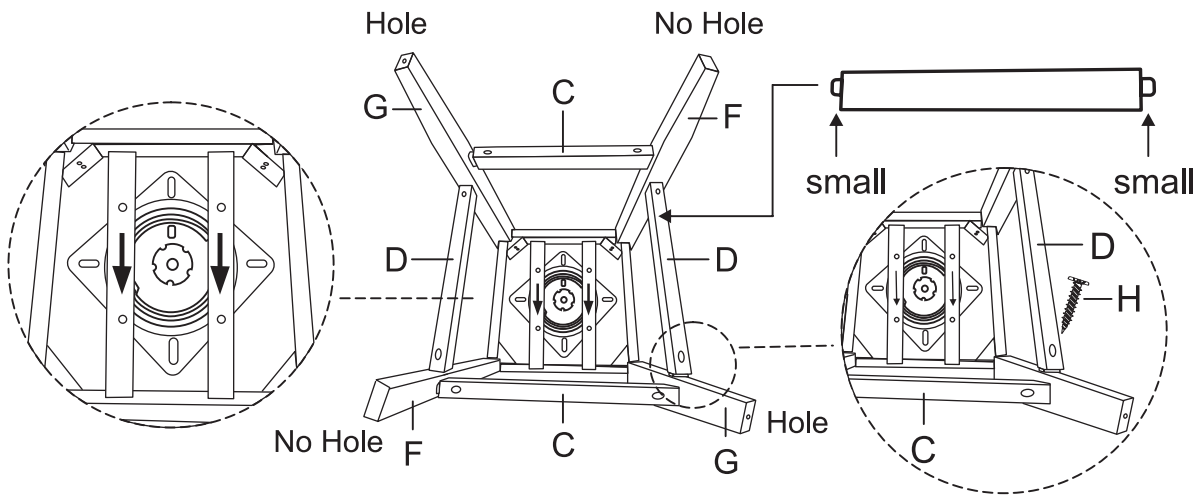

FACING FRONT TOWARD ARROW

5 Invert Cushion Seat (B) and place on a stable raised surface (i.e. Table). Attached the Backrest (A) to the Cushion Seat (B) using JCBC Screw (K), Spring Washer (M), Flat Washer (L) with Allen Key (N).

Then, affix the center JCBC Screw (J), Spring Washer (M), Flat Washer (L) with Allen Key (N).

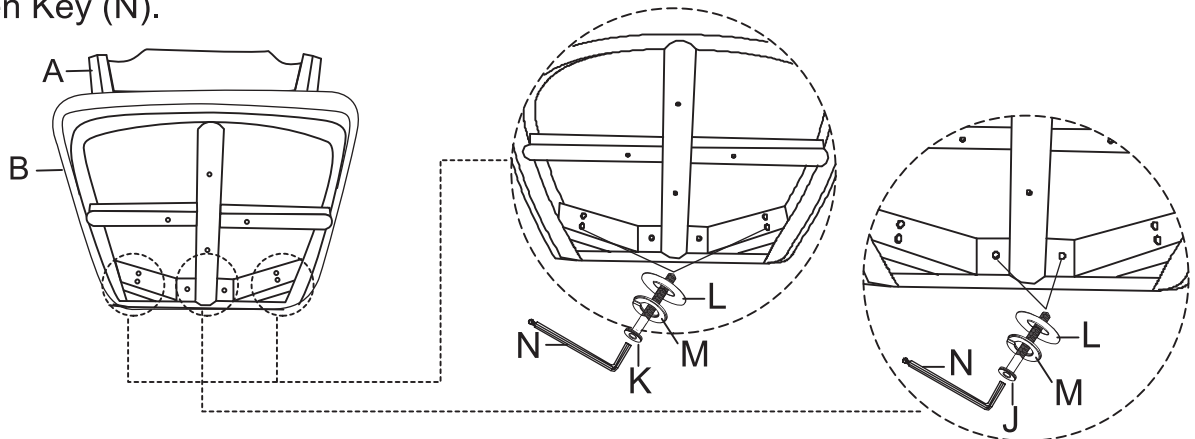

6 Keep the Backrest (A) and Cushion Seat (B) inverted on a stable raised surface. Attached the Swivel Plate located on the Apron with Swivel Plate (E) to the Cushion Seat (B) using JCBC Screw (I), Flat Washer (L) with Allen Key (N). Turn the Chair right side up.

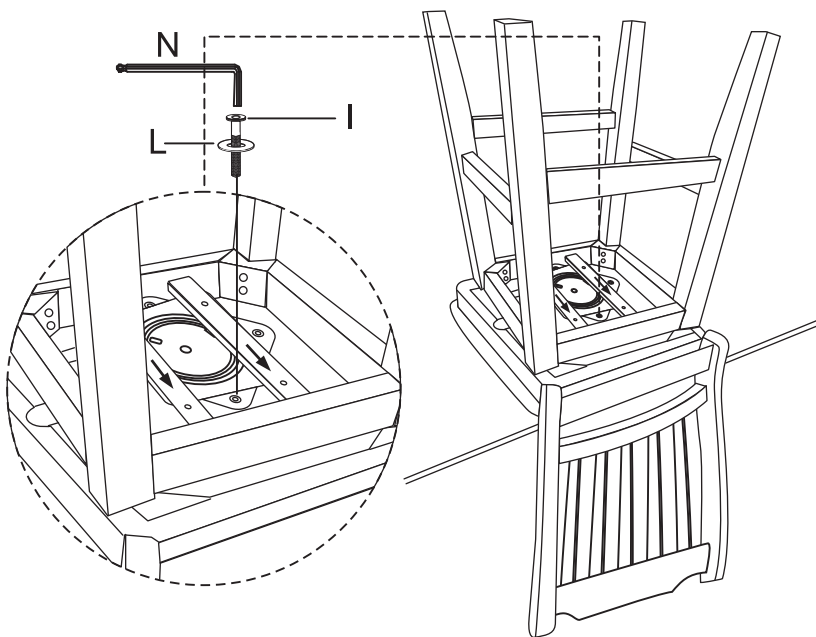

FACING FRONT TOWARD ARROW

Stand chair up on an even surface and check that it is balanced. If there is a slight wobble, apply downward pressure in the corner where a leg is uneven. Keeping pressure in that corner, tighten all bolts. If balanced, apply downward pressure evenly in the center and tighten all bolts. Do not over-tighten beyond hole depth.

Helpful Tip:

- Instead of applying downward pressure while reaching under to tighten bolts, have someone sit on the chair while you tighten the bolts.

ENSURE THAT ALL SCREWS ARE FULLY DRIVE IN AND TIGHTEN BEFORE READY TO USE.

CLEANING & CARE

Treat surface with care. Surface is resistant to scratches but is not scratch resistant. Clean surfaces with a dry or damp soft cloth. Do not use abrasive cleaners. Hardware may loosen over time. Periodically check that all connections are tight.