

ASSEMBLY INSTRUCTION

A Table Leg Frame

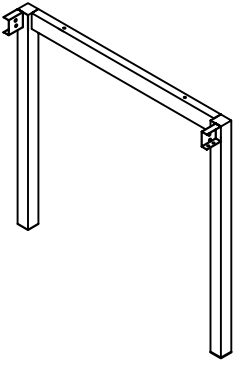

2PCS

B Table Top

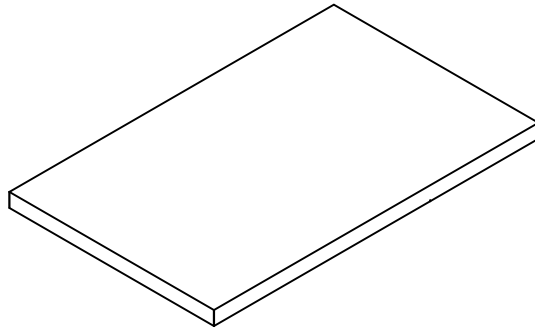

1PC

C Apron

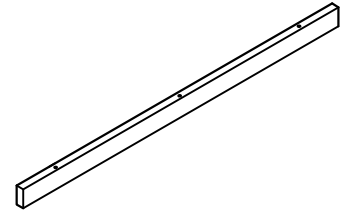

2PCS

D Bolt
1/4"*16mm



16PCS

E Screw
5mm*70mm

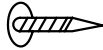

10PCS

F L-Allen Key
4mm

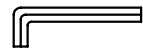

1PC

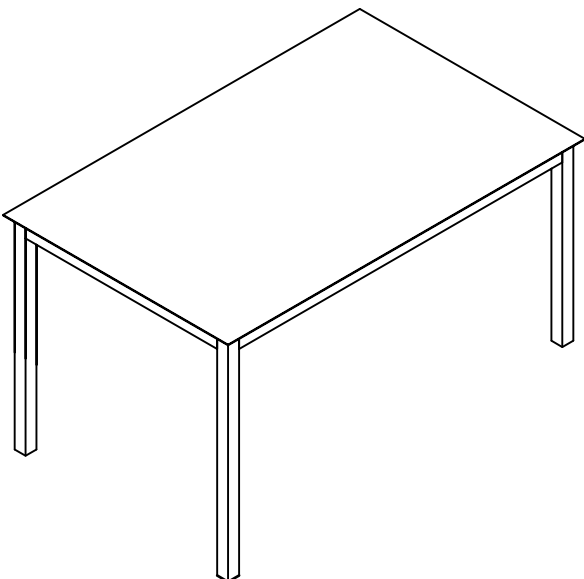

This page lists all the contents included in the box. Please take the time to identify the hardware as well as the individual components to this product. As you unpack and prepare for assembly, place the contents on a carpeted or padded area to protect them from damage.

1

Align the Table Leg Frame(A) to Apron(C) and tighten with Bolts(D). Turn the L-Allen Key(F) in Bolts(D) to tighten them.

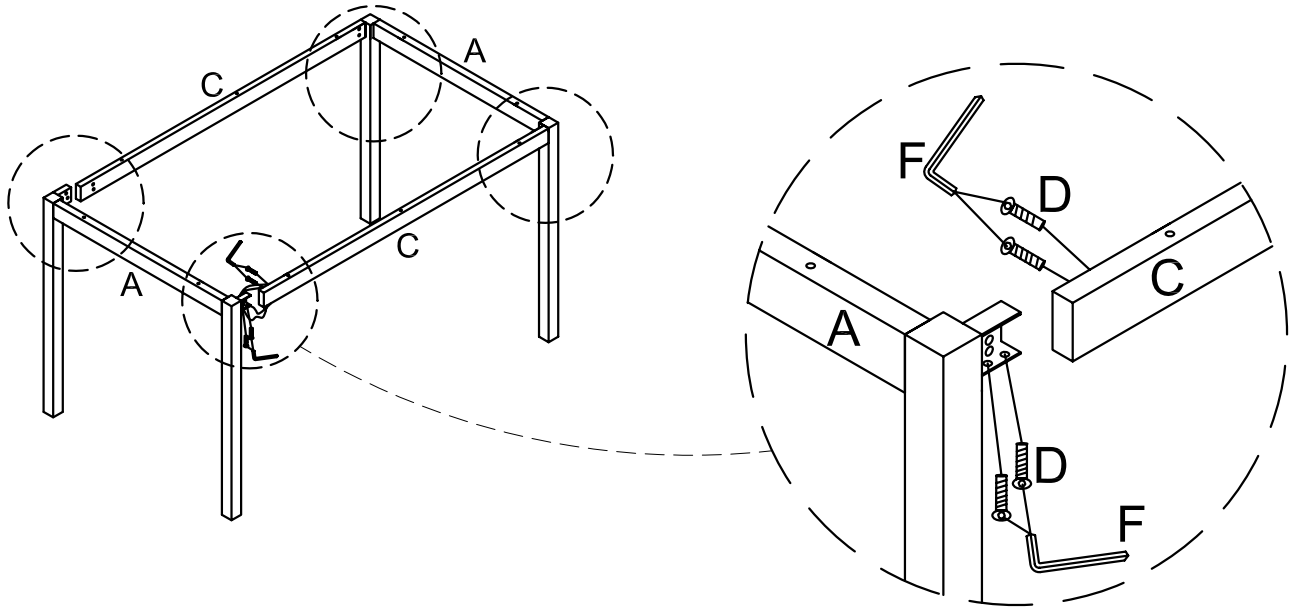
**2**

Place the Table Top(B) on the smooth and stable carpeted or padded surface. Tighten attached table frame to table top with Screws(E).

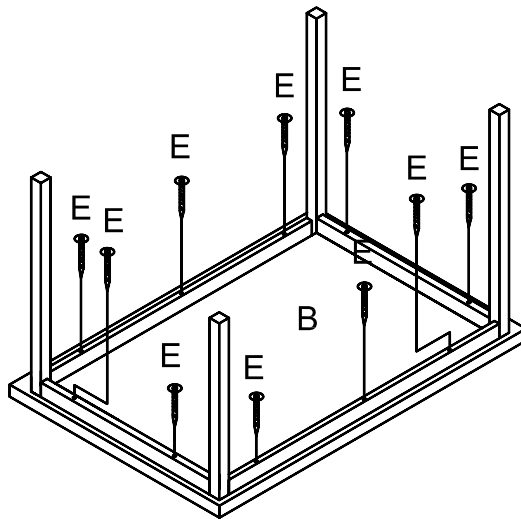

Cleaning & Care

Treat surface with care. Surface is resistant to scratches but is not scratchresistant. Clean surfaces with a dry or damp soft cloth. Do not use abrasive cleaners. Hardware may loosen over time. Periodically check that all connections are tight.

ASSEMBLY INSTRUCTION

PART LIST:

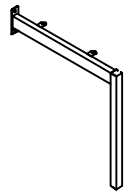

Left Side Frame
1PC

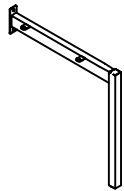

Right Side Frame
1PC



Chair Back
1PC

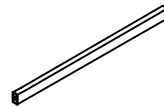

Front Rail
1PC

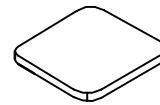

Seat Cushion
1PC

HARDWARE LIST

HARDWARE LIST				
A		Long Bolt	1/4"*19mm	2pcs
B		Short Bolt	1/4"*16mm	4pcs
C		Screw	4mm*20mm	4pcs
D		L-Allen Key	4mm	1pc

STEP 1

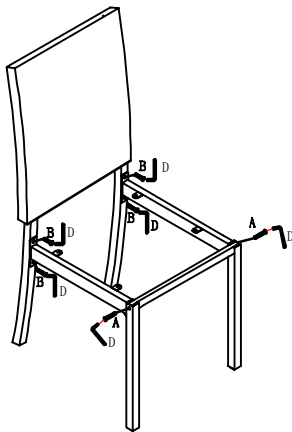

STEP 2

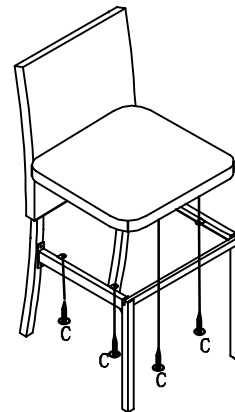

COMPLETED

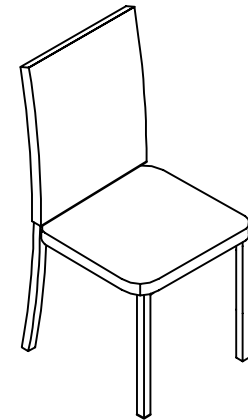

(1) Align the left side frame/right side frame to the chair back and front rail, insert the bolt to the holes and tighten it.

(2) Attach the seat cushion to the seat, insert the screw then tighten it.