

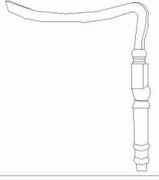







# ASSEMBLY INSTRUCTION

## HF-151-C CHAIR

### SKU# 11041790

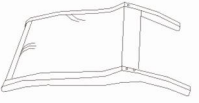
#### PARTS LIST

PARTS#	PARTS NAME	DRAWING	QTY	PARTS#	PARTS NAME	DRAWING	QTY
A	FLAT WASHER 5/16"X 3/4"		11	I	ARM		2
B	LOCK WASHER 5/16"		11				
C	BOLTS DIA 5/16"X3"		4				
D	BOLTS DIA 5/16"X2"		6	J	CUSHION		1
E	BOLTS DIA 5/16"X1 3/4"		1				
F	ALLEN WRENCH 5/16		1	K	BACK		1
G	PLASTIC COVER 25/ 32"		2				
H	TENON 10X25mm		2				

#### STEP 1.

Remove all parts from carton and separate them into part number as indicated. Place the chair back on a smooth flat surface with holes facing up

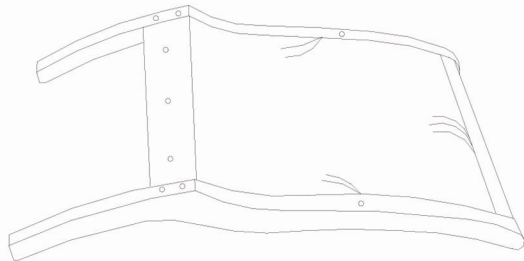

#### STEP 2.

Attach Seat Cushion and Back Cushion using Bolts with lock washer and flat washer(C+B+A) for both Left side. Facing("LSF")& Right side facing("RSF")using Bolt, lock washer and flat washer(E+B+A) for centre hole. Tighten slightly not fully.

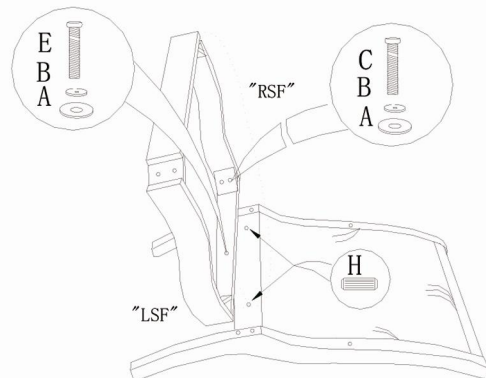

#### STEP 3.

Tighten slightly the front leg with the arm not fully.

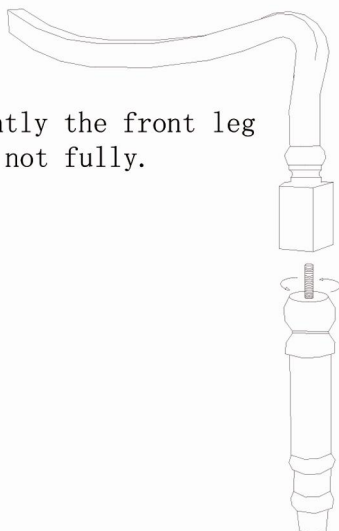

#### STEP 4.

Attach ARM using Bolt with lock washer and flat washer(D+B+A) and (D+B+A) for the Arm surface. Using the Allen wrench(F) tighten slightly not fully. Place the chair on the floor ensure chair upright leveling is all right. Tightening all screw fully.

