

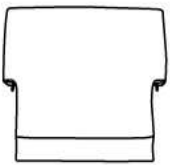







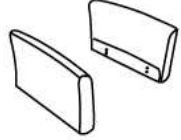

Please unscrew all hardware from cushion before assembly.
Por favor de destornillar todos los tornillos del cojín antes de ensamblar la silla.

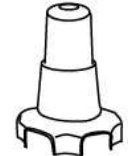
MODEL : B616

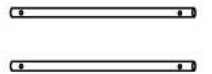
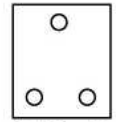
(1)x1  TU616-B/Back Cushion	(2)x1  TU616-S/Seat Cushion	(3)x1 (L)x1 (R)  TU616-LARM/Left Arm TU616-RARM/Right Arm
(4)x1  TU026/Gas Lift	(5)x1  TU026-C/Gas Lift Cover	(6)x1  TU001/Mechanism
(7)x 1  TU030 & TU015-W/Wood Base & Casters	(8)x 1  TU619-CB / Connecting Bar	(9)x2  Metal Bracket
(A)x6  M6*22 Bracket Screws	(C)x4  M8*22 Mechanism Screws	
(B)x4  M6*36 Bar Screws	(D)x1 	

Insert and loosely tighten all screws. When assembly is completed, fully tighten all screws before using. This chair is only intended for sitting. Any other use will void the warranty.



**Customer Service Hotline:
1-800-593-1888**

For further assembly instructions, please visit our website at www.bosschair.com

